

Simpson Strong-Tie  
66L

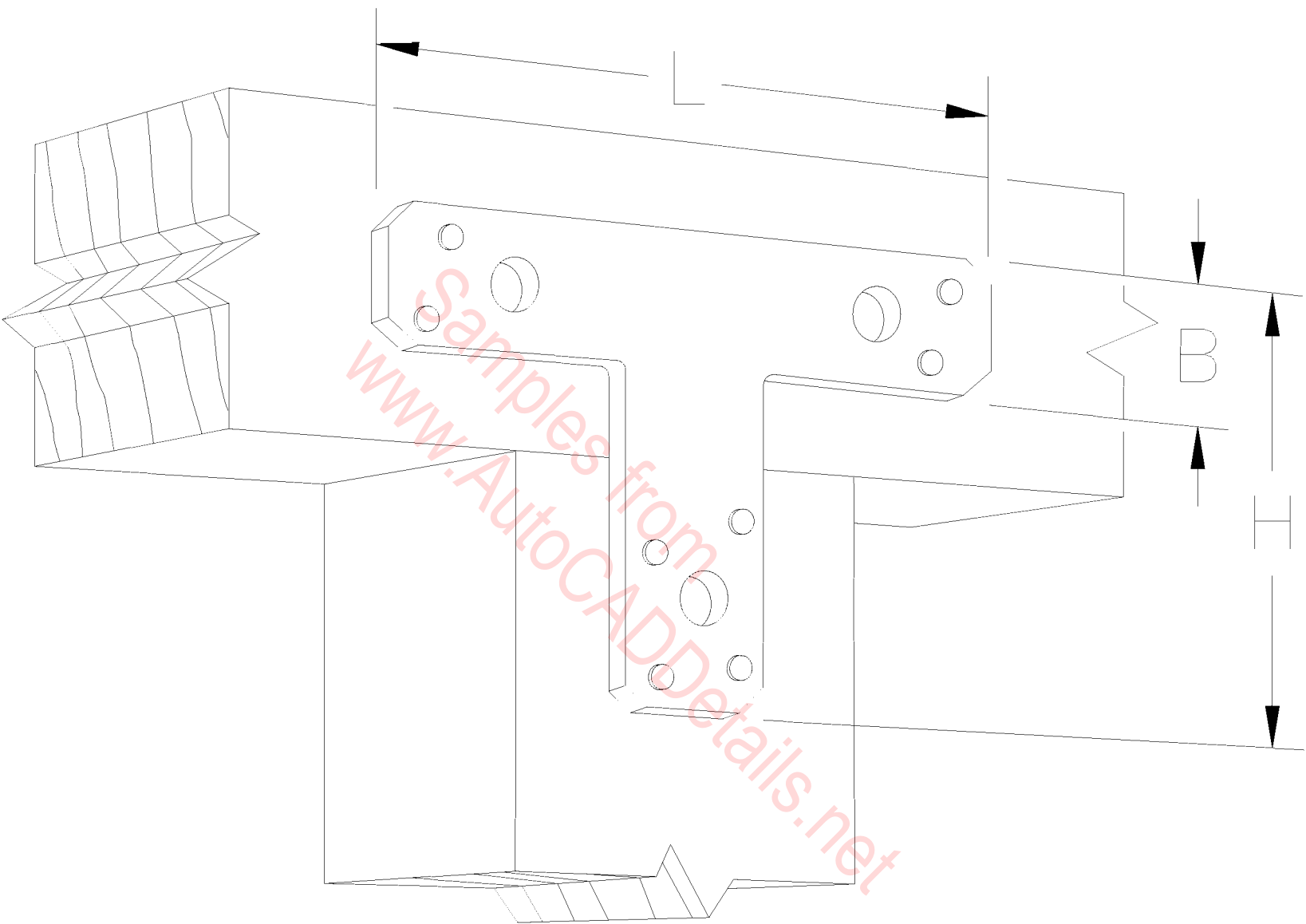

Simpson Strong-Tie  
66T

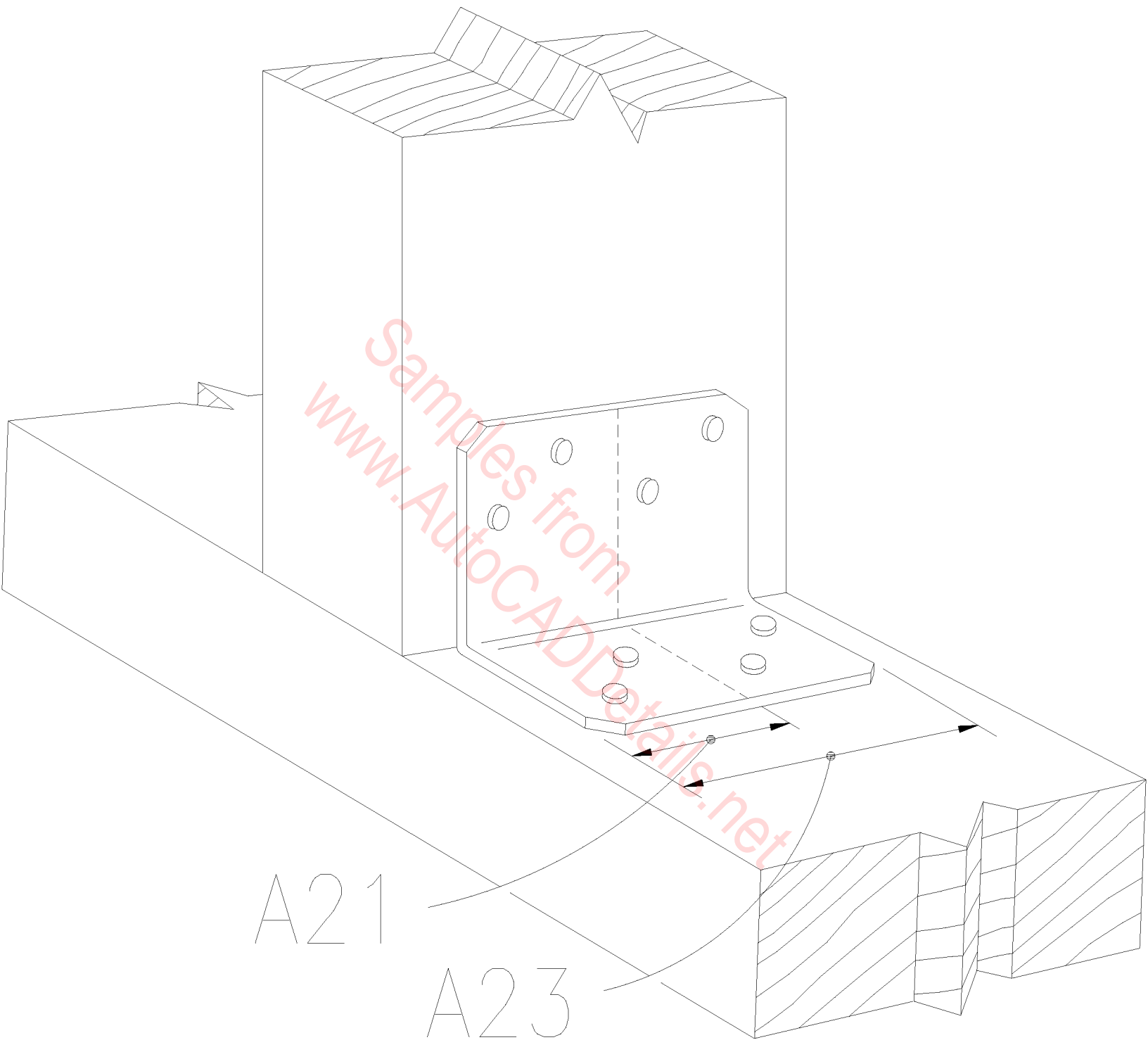

A21

A23

Simpson Strong-Tie  
A21 and/or A23 Angle

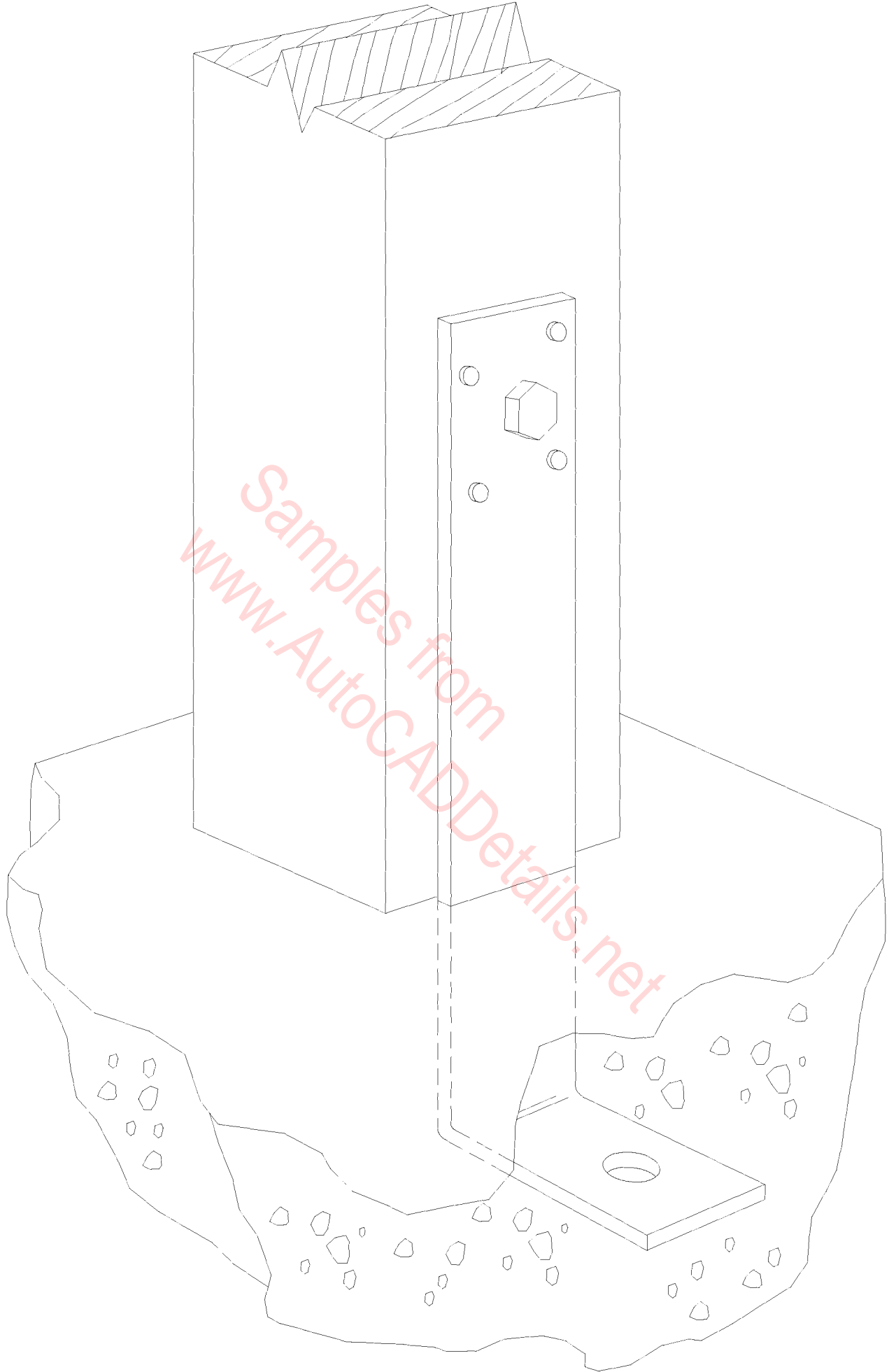

Simpson Strong-Tie  
A311 Angle

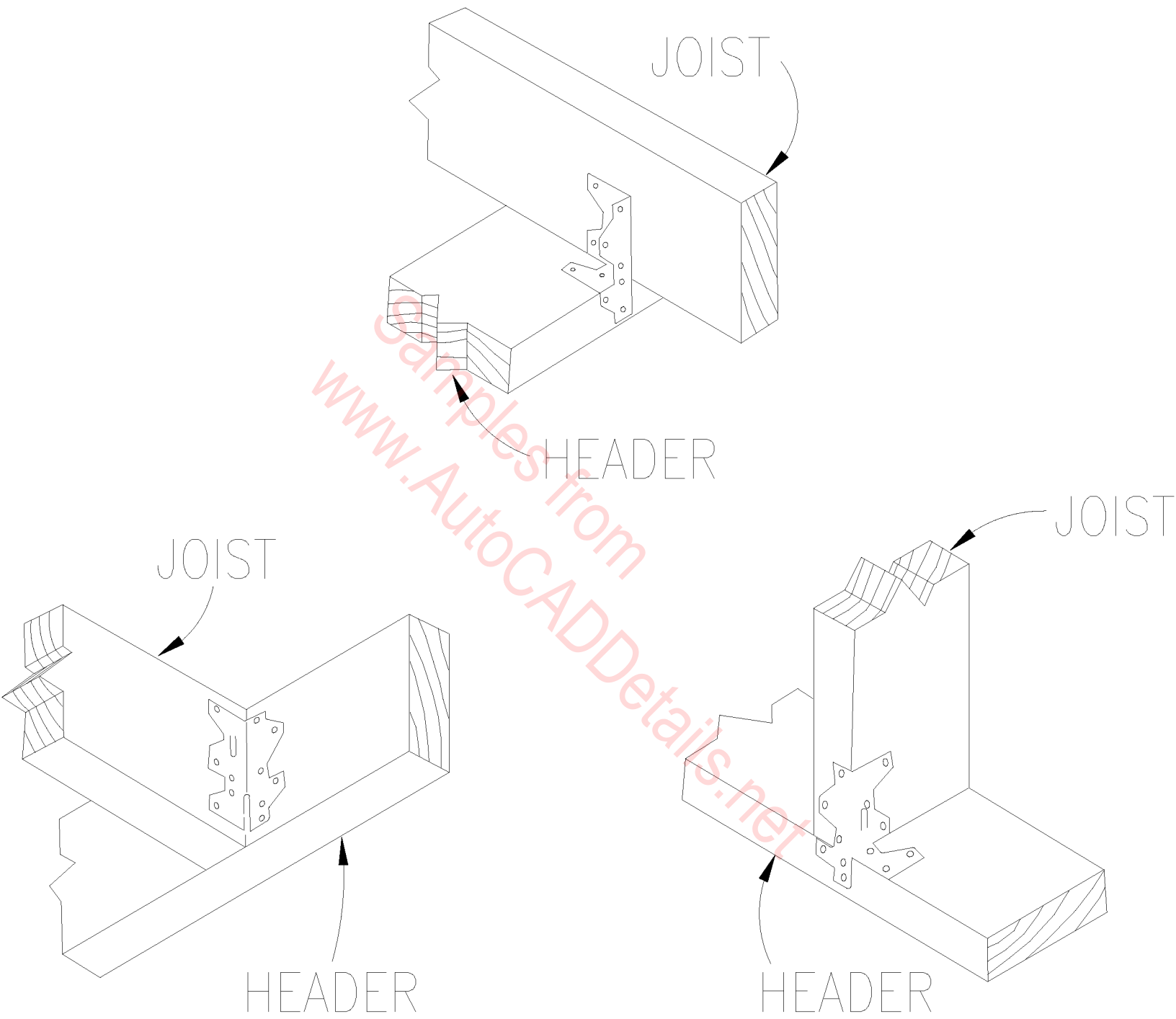

Simpson Strong-Tie  
A35 Framing Anchor

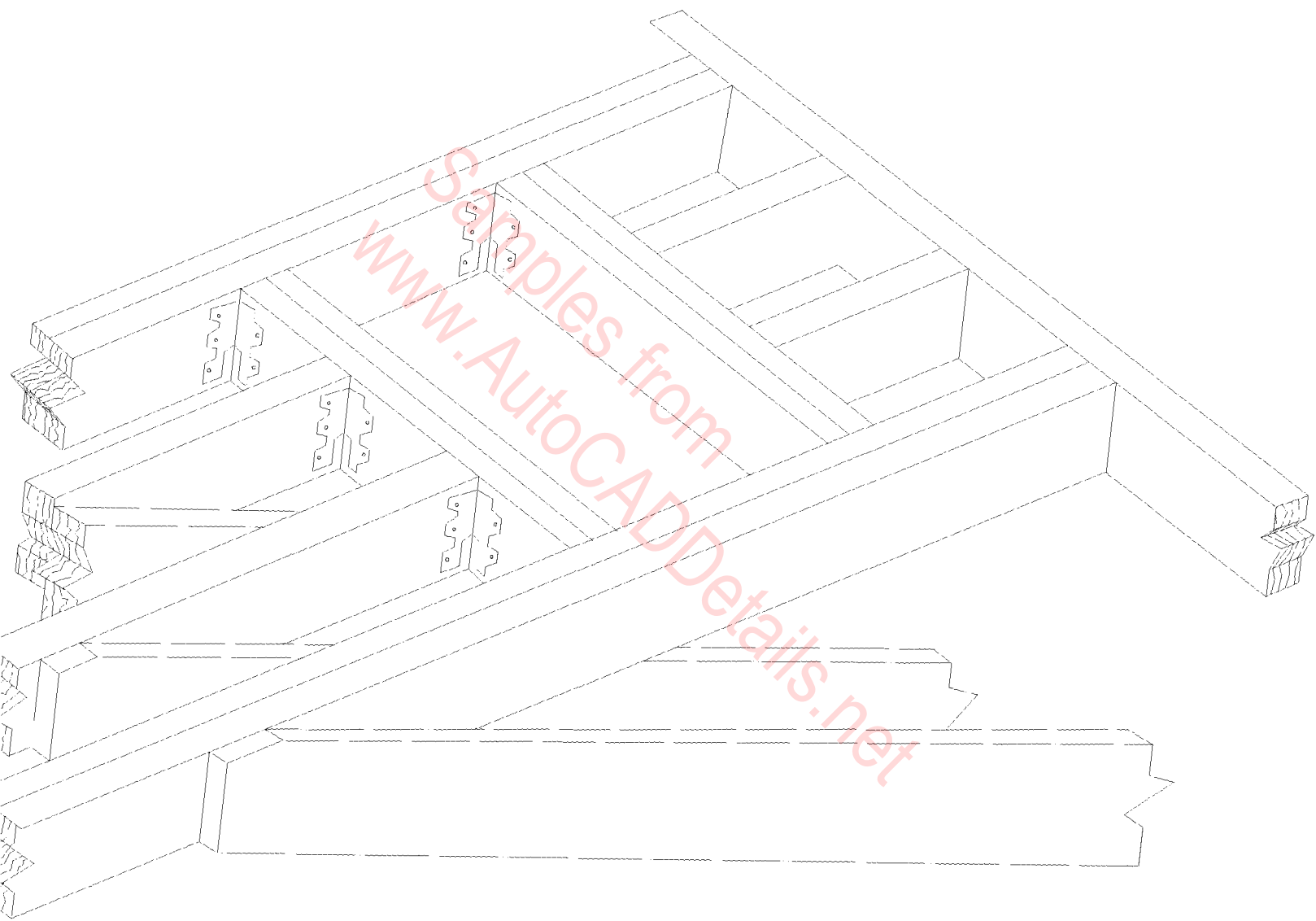

Simpson Strong-Tie  
A35 Chimney Framing

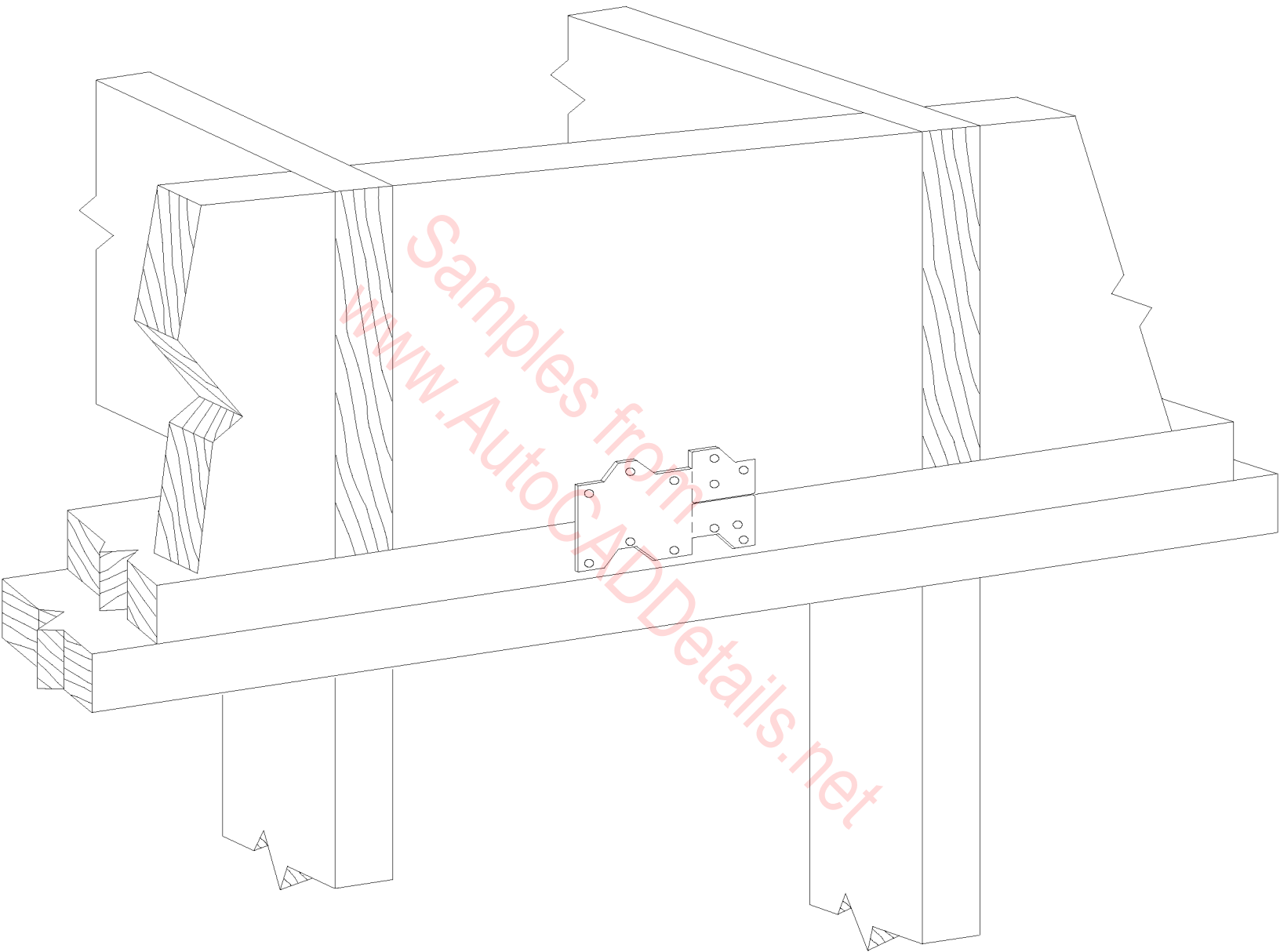

Samples from  
[www.AutocADDetails.net](http://www.AutocADDetails.net)

Simpson Strong-Tie  
A35F

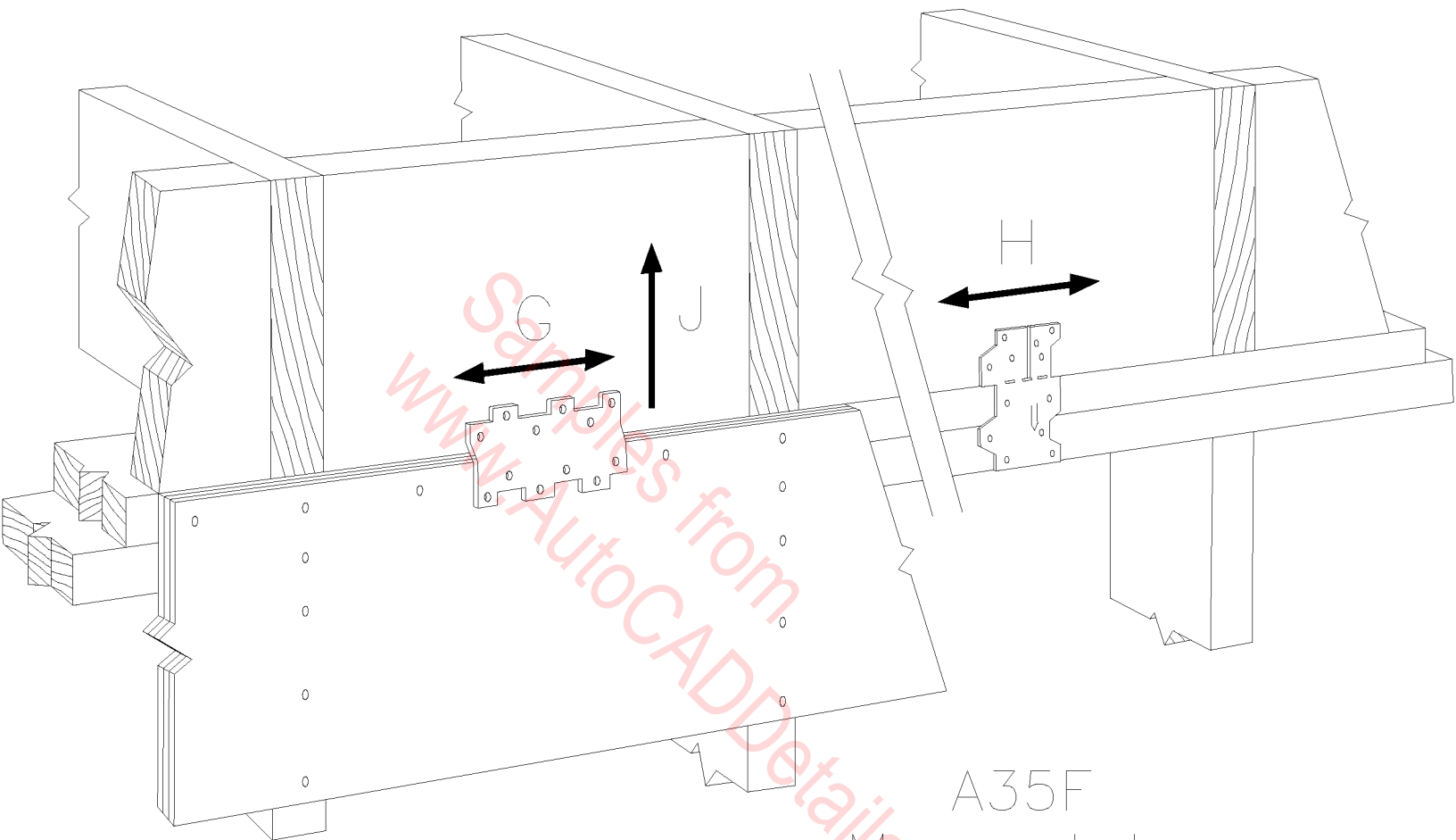

LTP4 on  
plywood  
sheathing

A35F  
May not be  
installed over  
sheathing

Simpson Strong-Tie  
A35F/LTP4



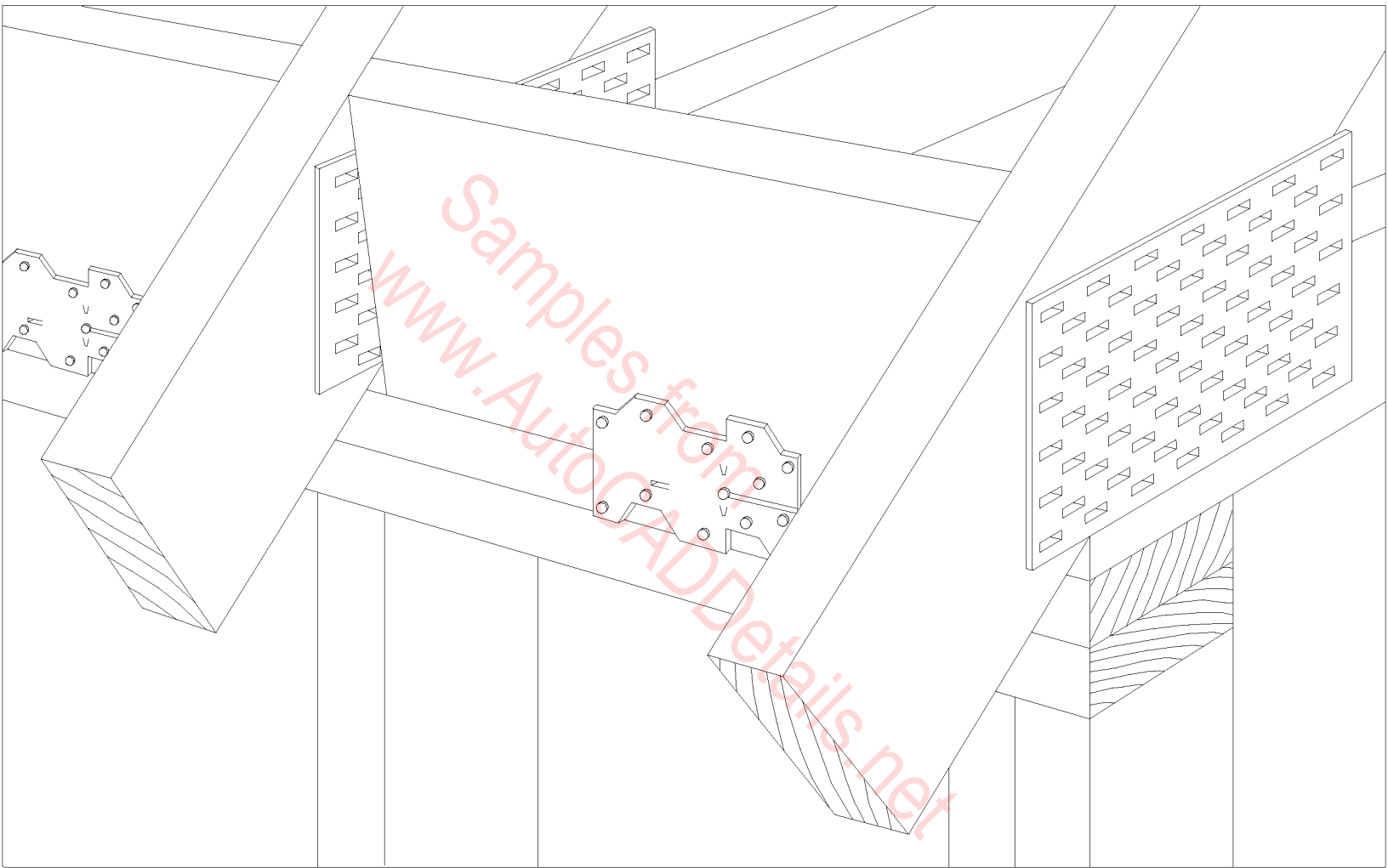

Simpson Strong-Tie  
A35F

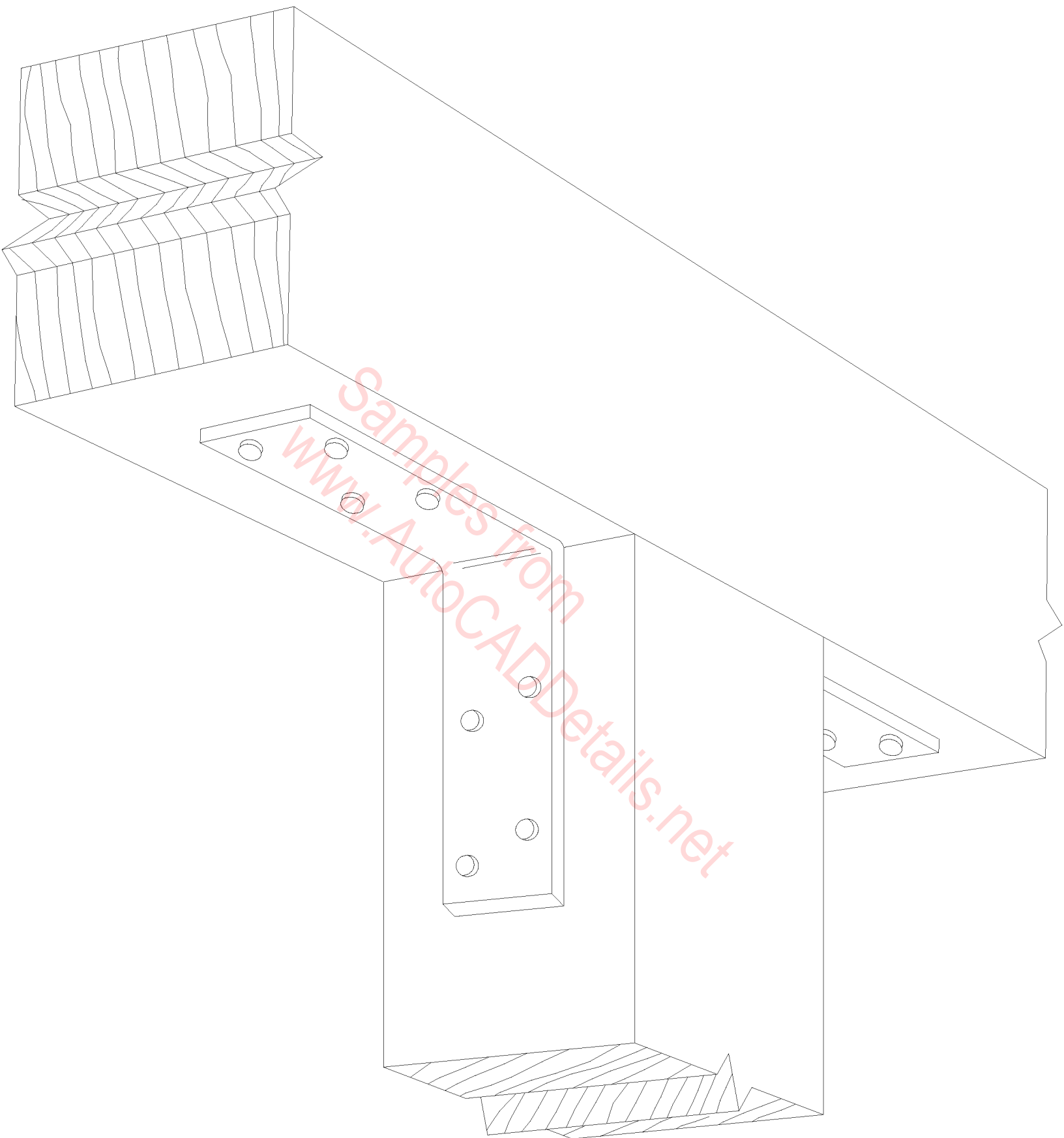

Simpson Strong-Tie  
A44 Angle

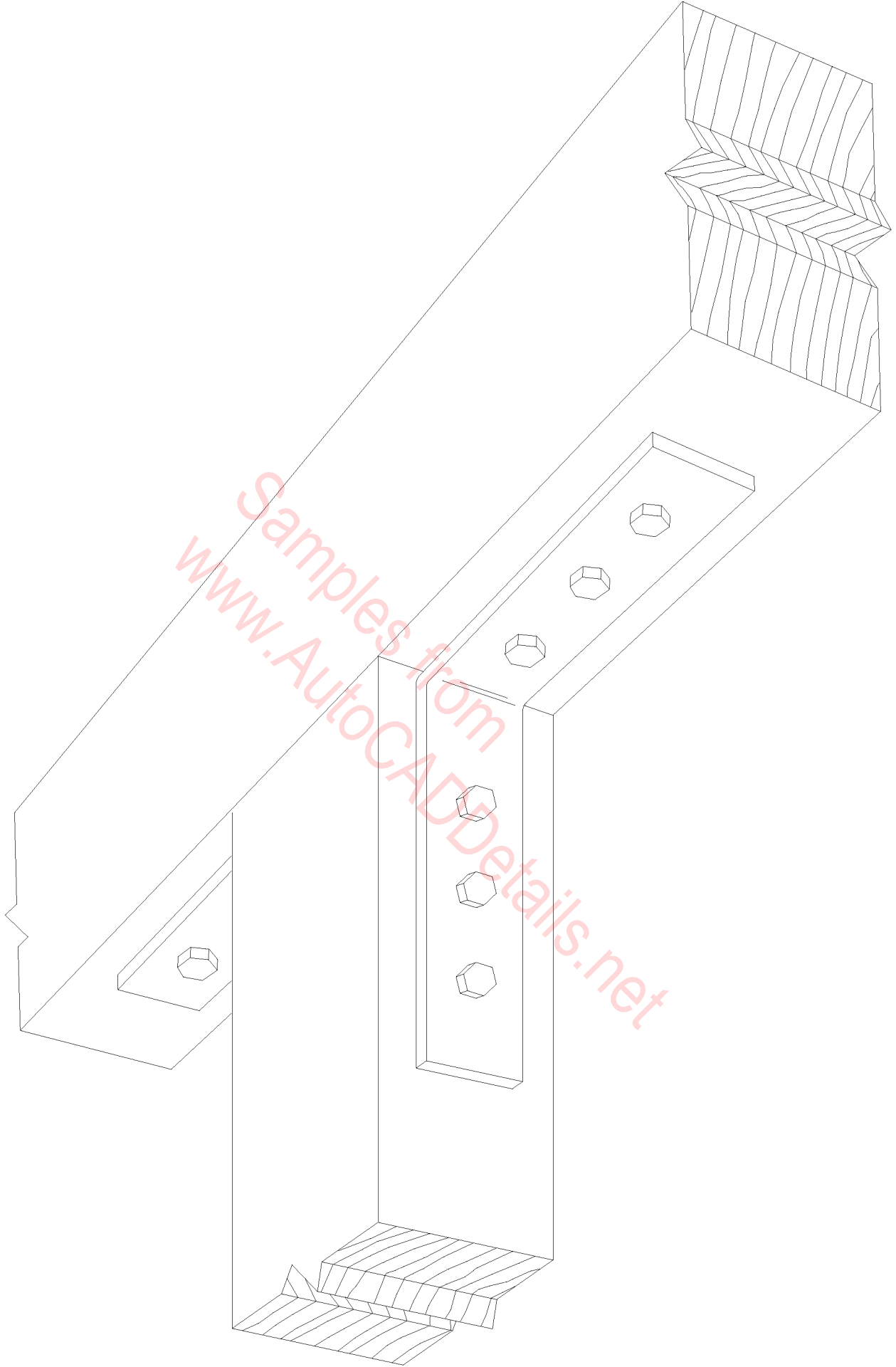

Simpson Strong-Tie  
A88 Angle

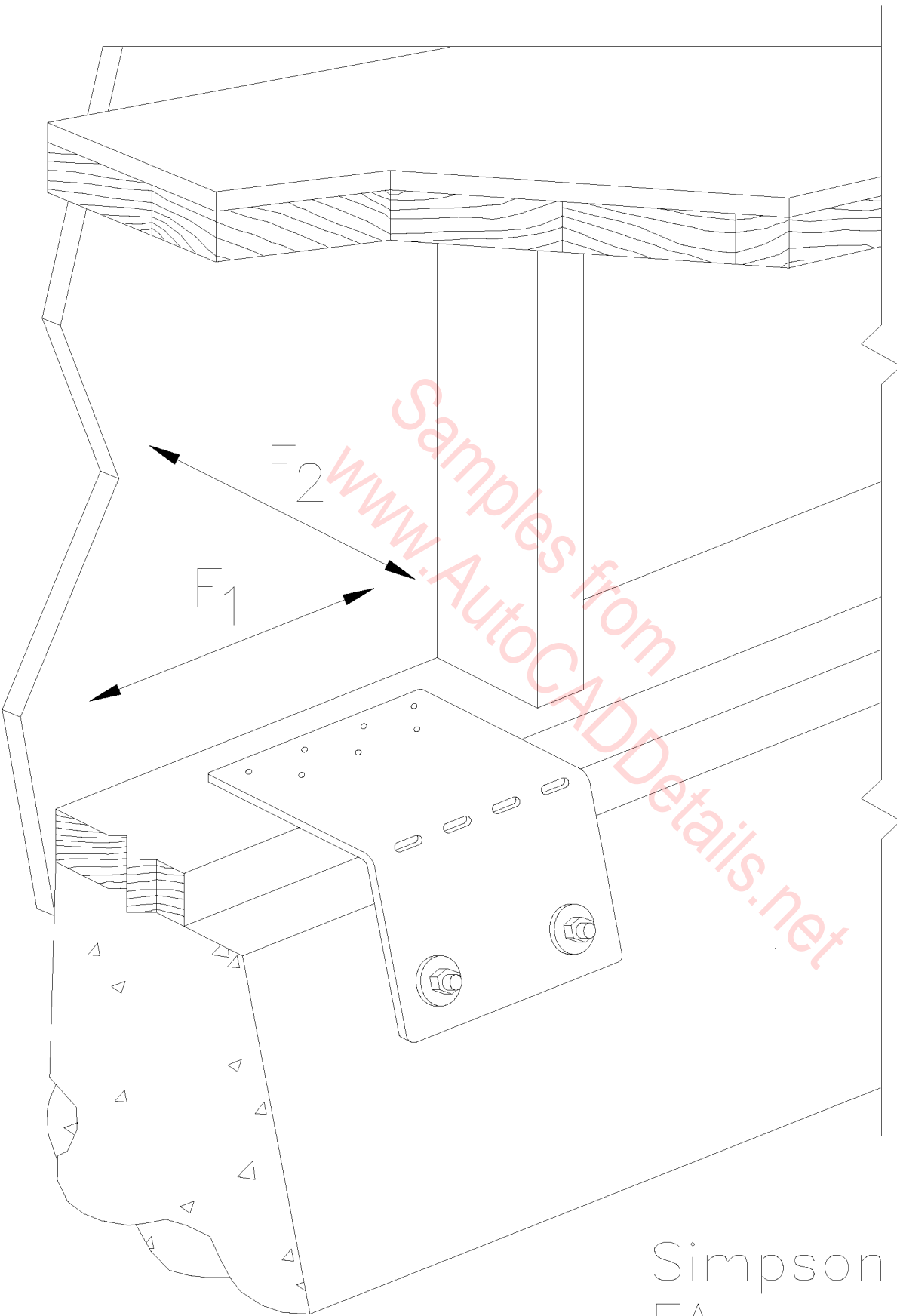

Simpson Strong-Tie  
FA

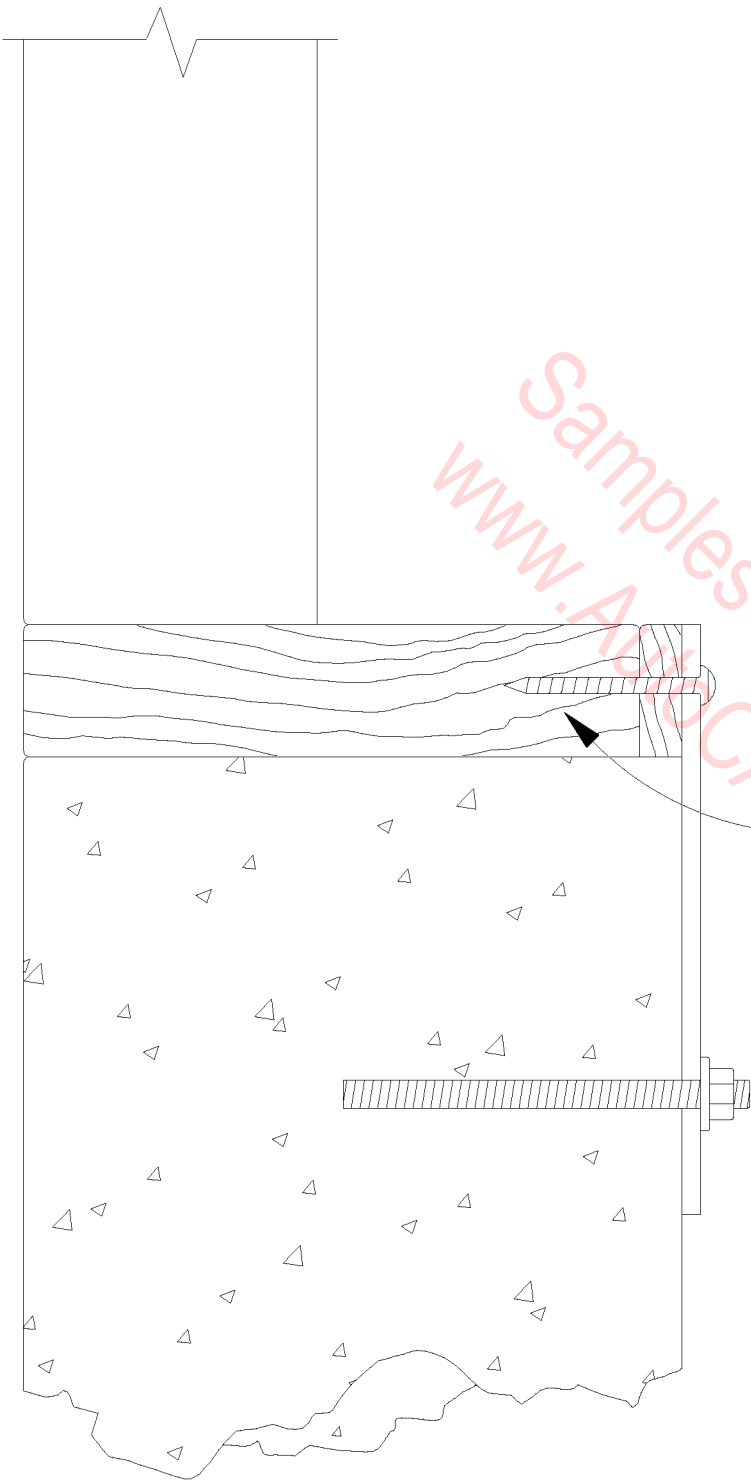

Samples from  
[www.ArchCADDetails.net](http://www.ArchCADDetails.net)

1/4" X 2 1/2"  
LAG PLUS  
SHIM THICKNESS

Simpson Strong-Tie  
FAP

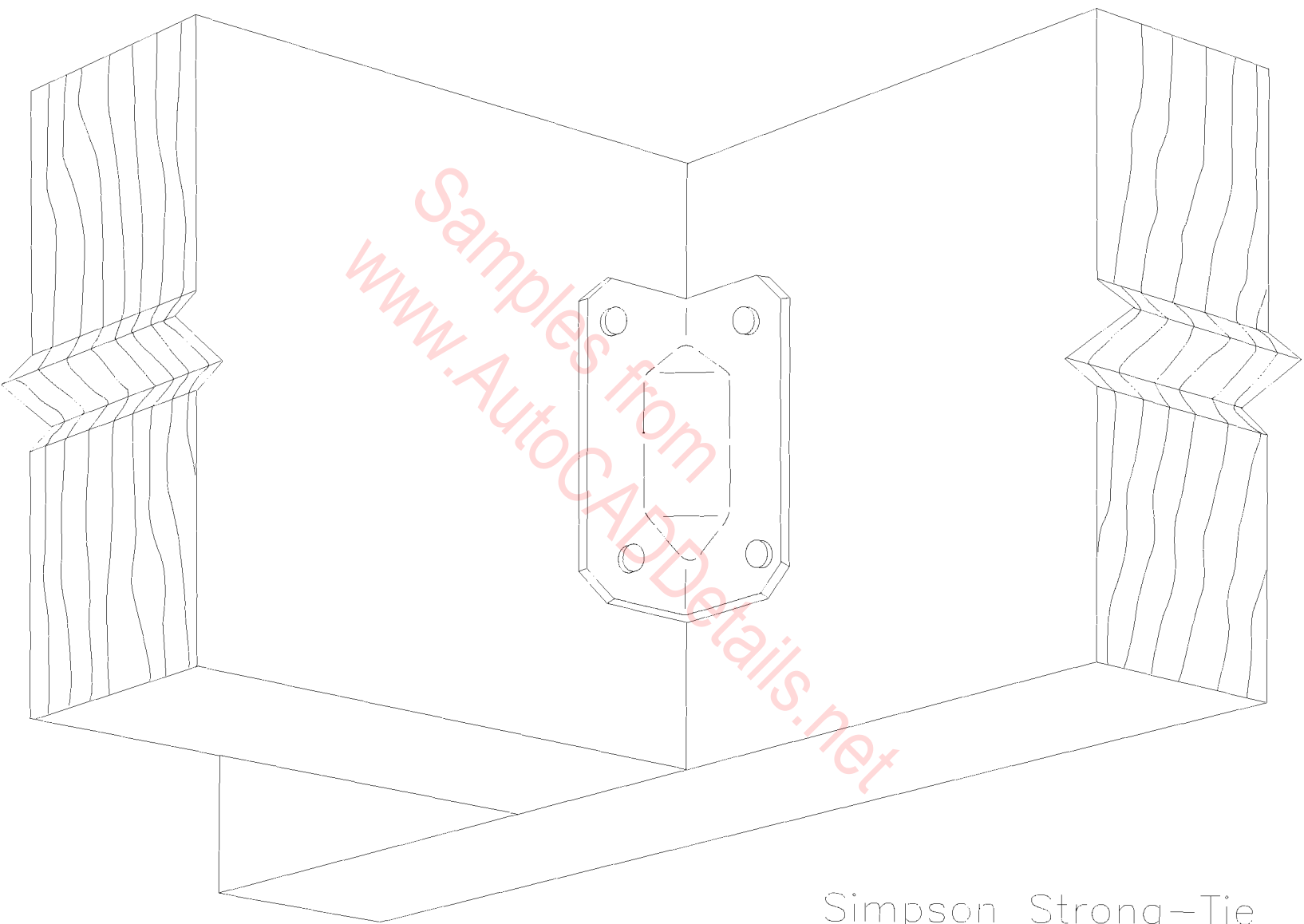

Simpson Strong-Tie  
GA1

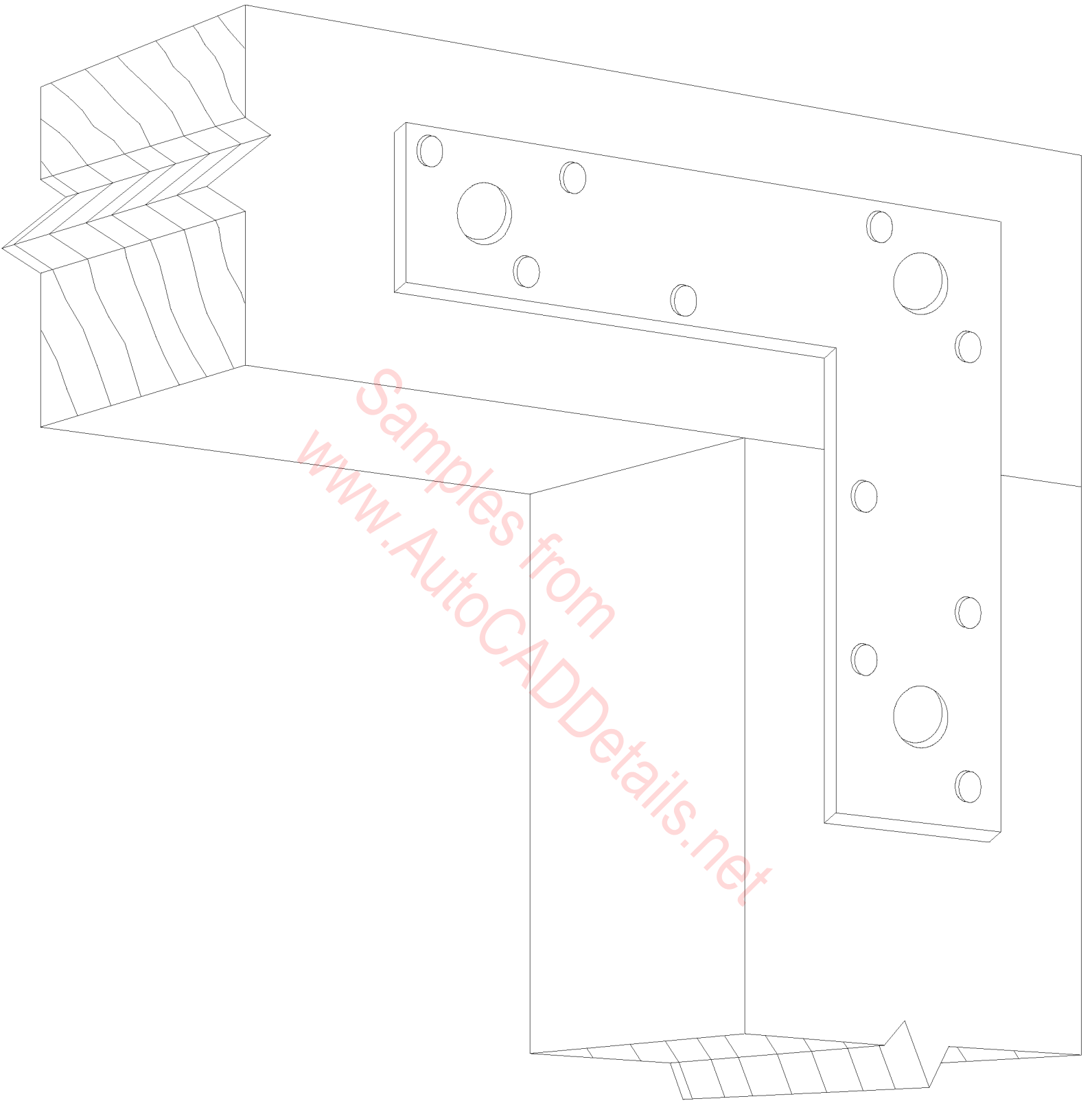

Samples from  
[www.AutoCADDetails.net](http://www.AutoCADDetails.net)

Simpson Strong-Tie  
L

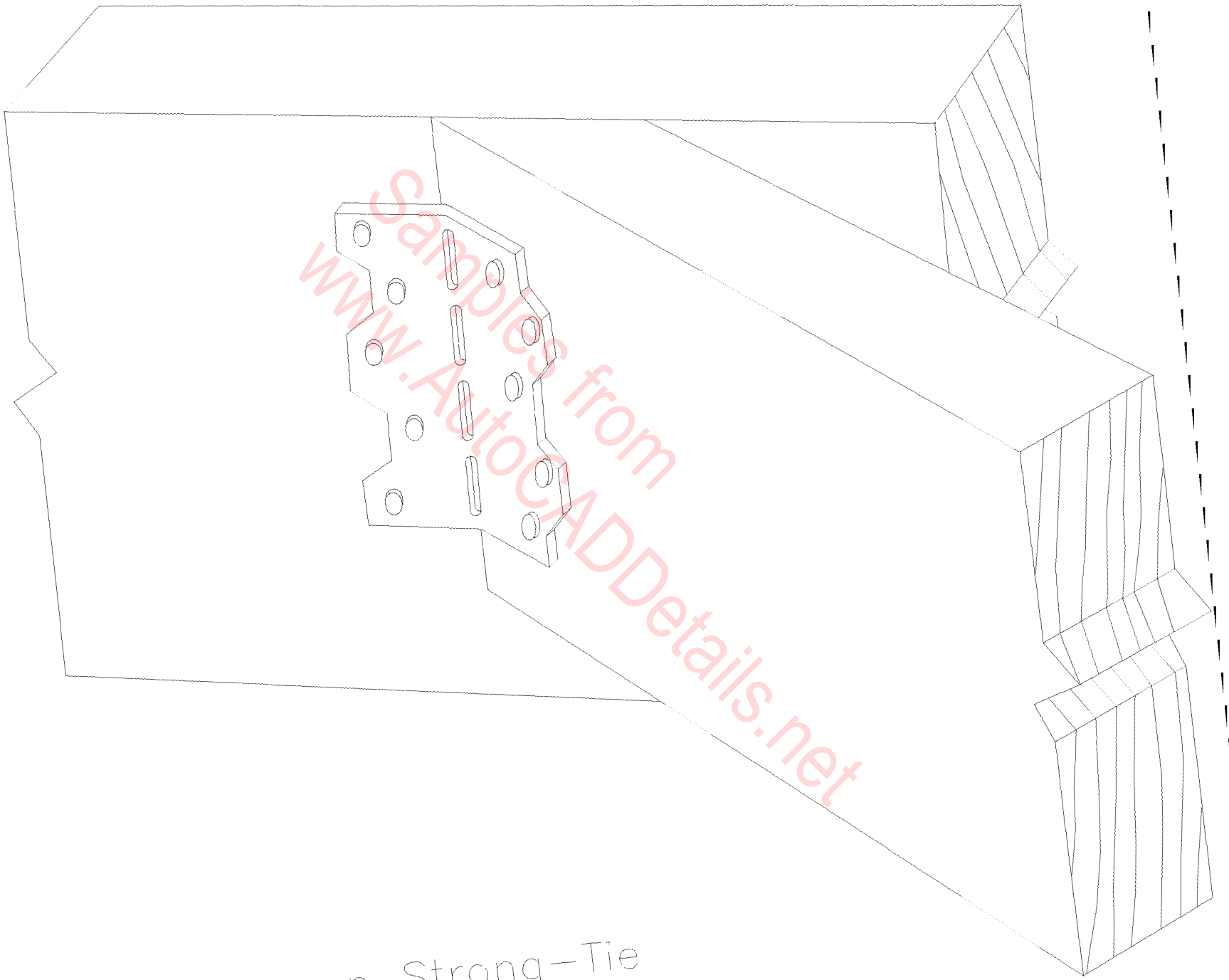

Simpson Strong-Tie  
LS70



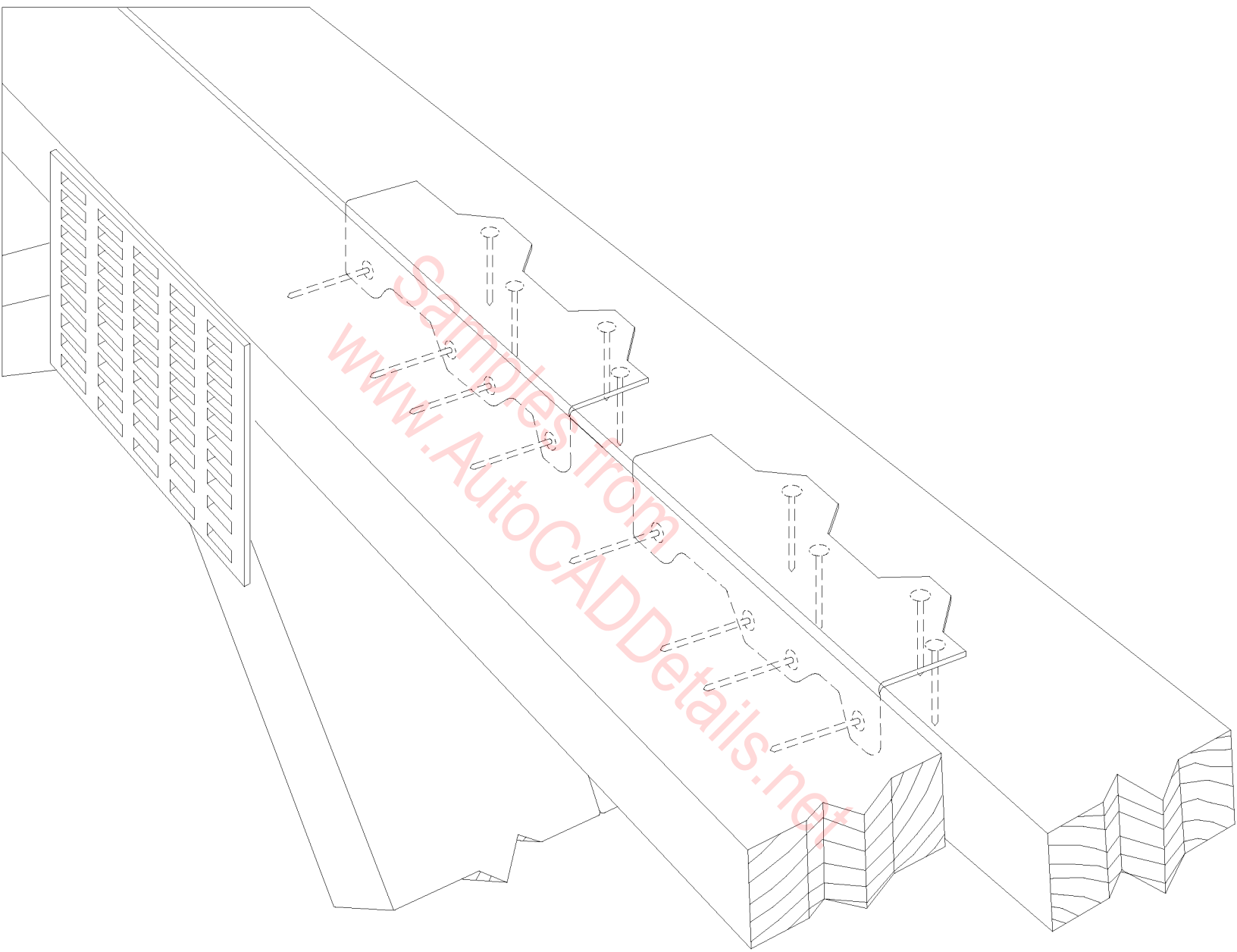

Simpson Strong-Tie  
L70NP

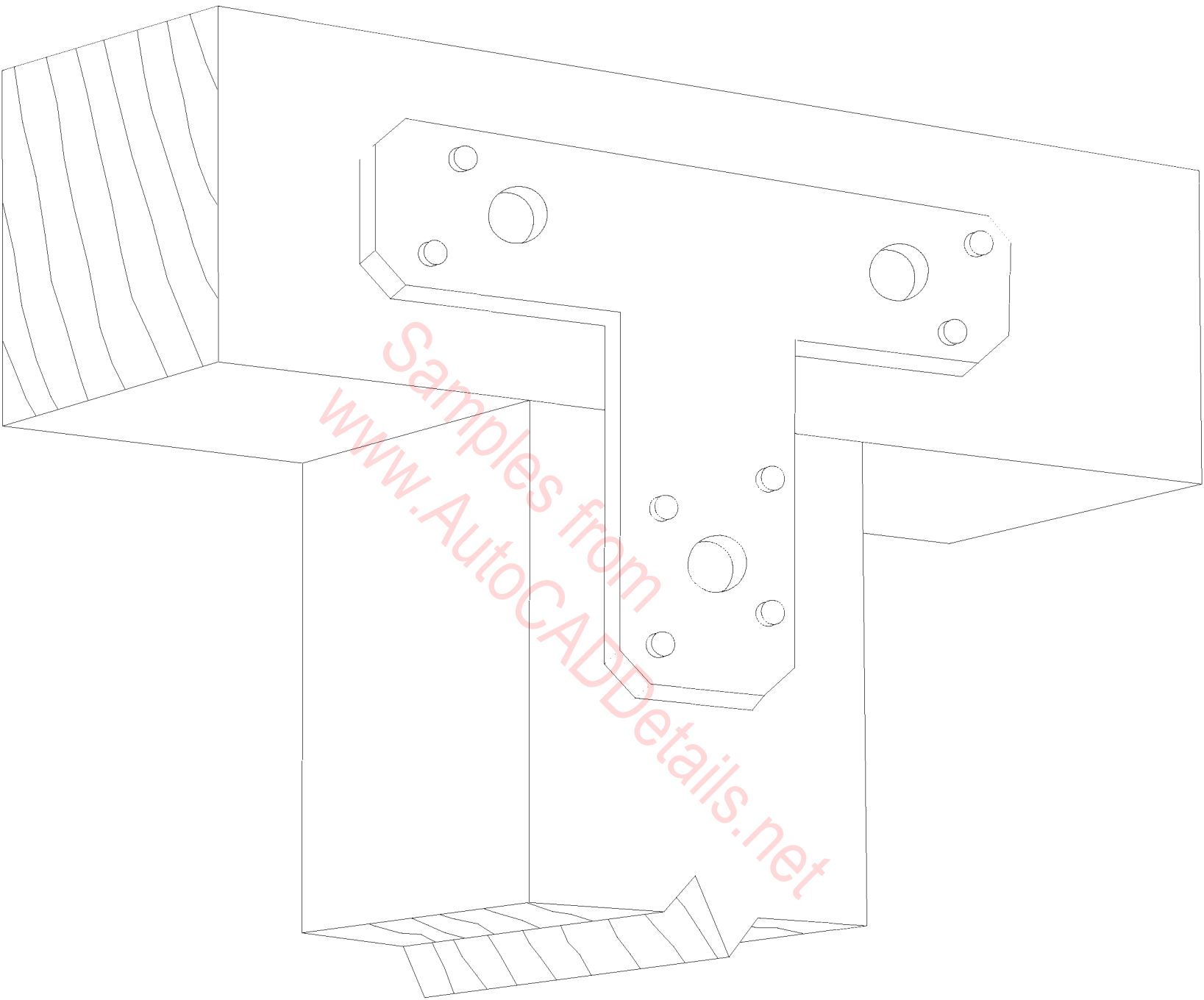

Simpson Strong-Tie  
T

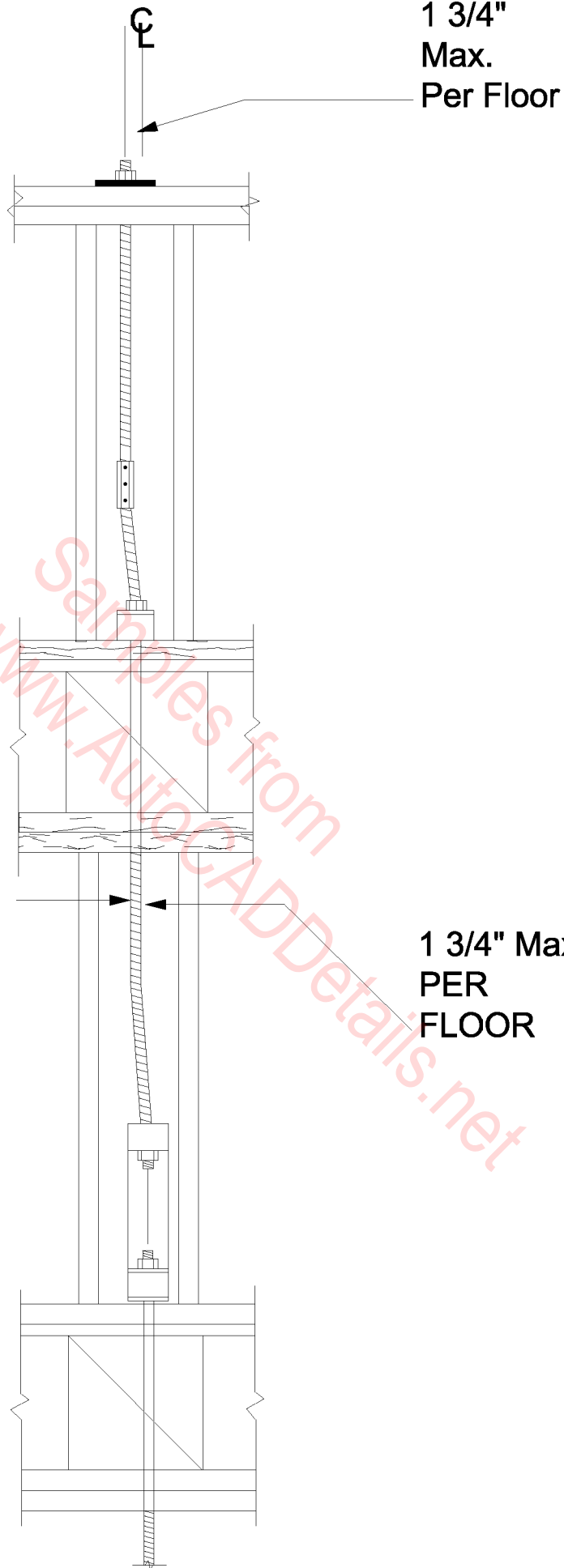

**Allowable Rod Offset.  
1 3/4" Max. per Floor**

Stud

1/8"

3" Max

# Alternate Blocking Detail

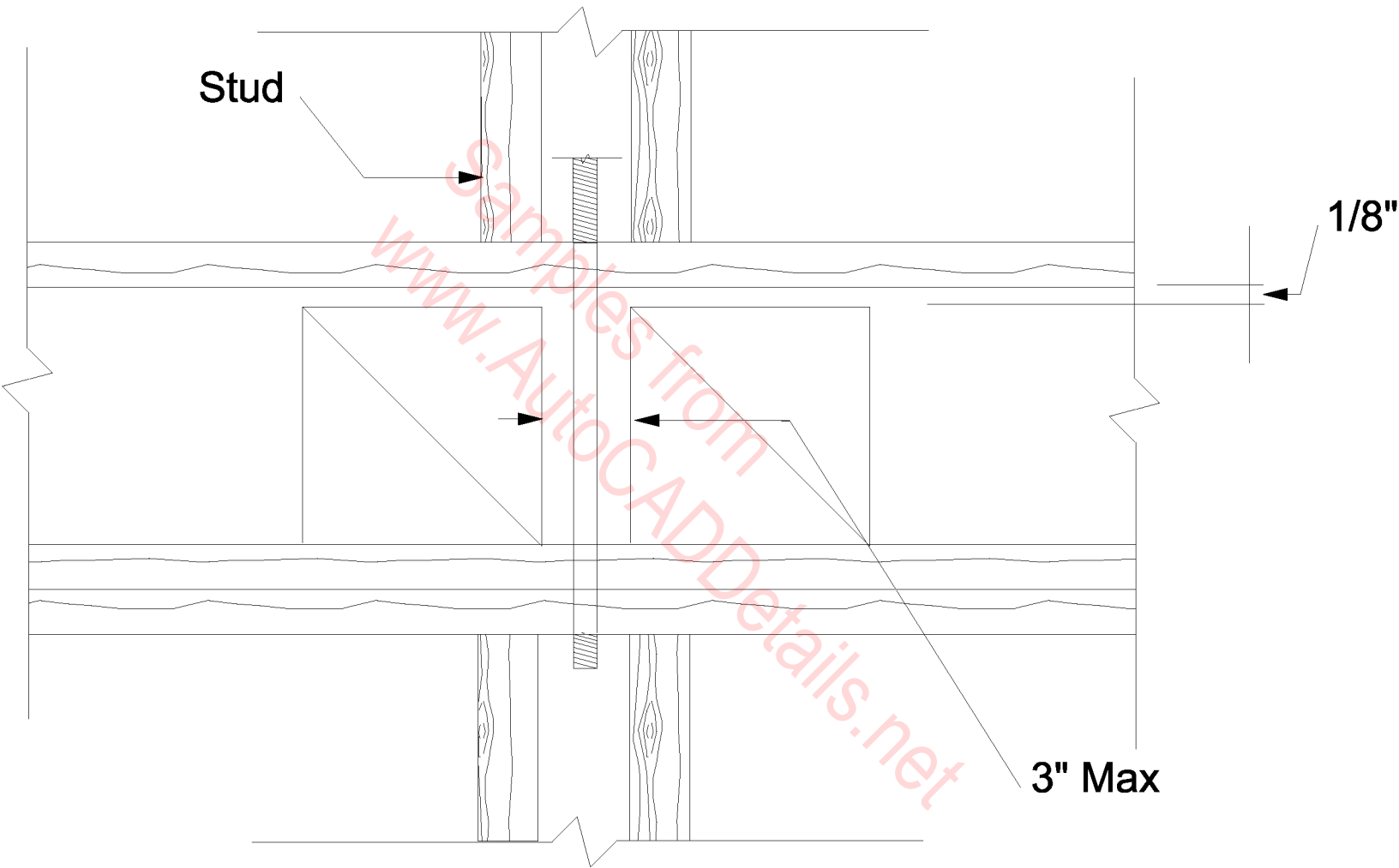

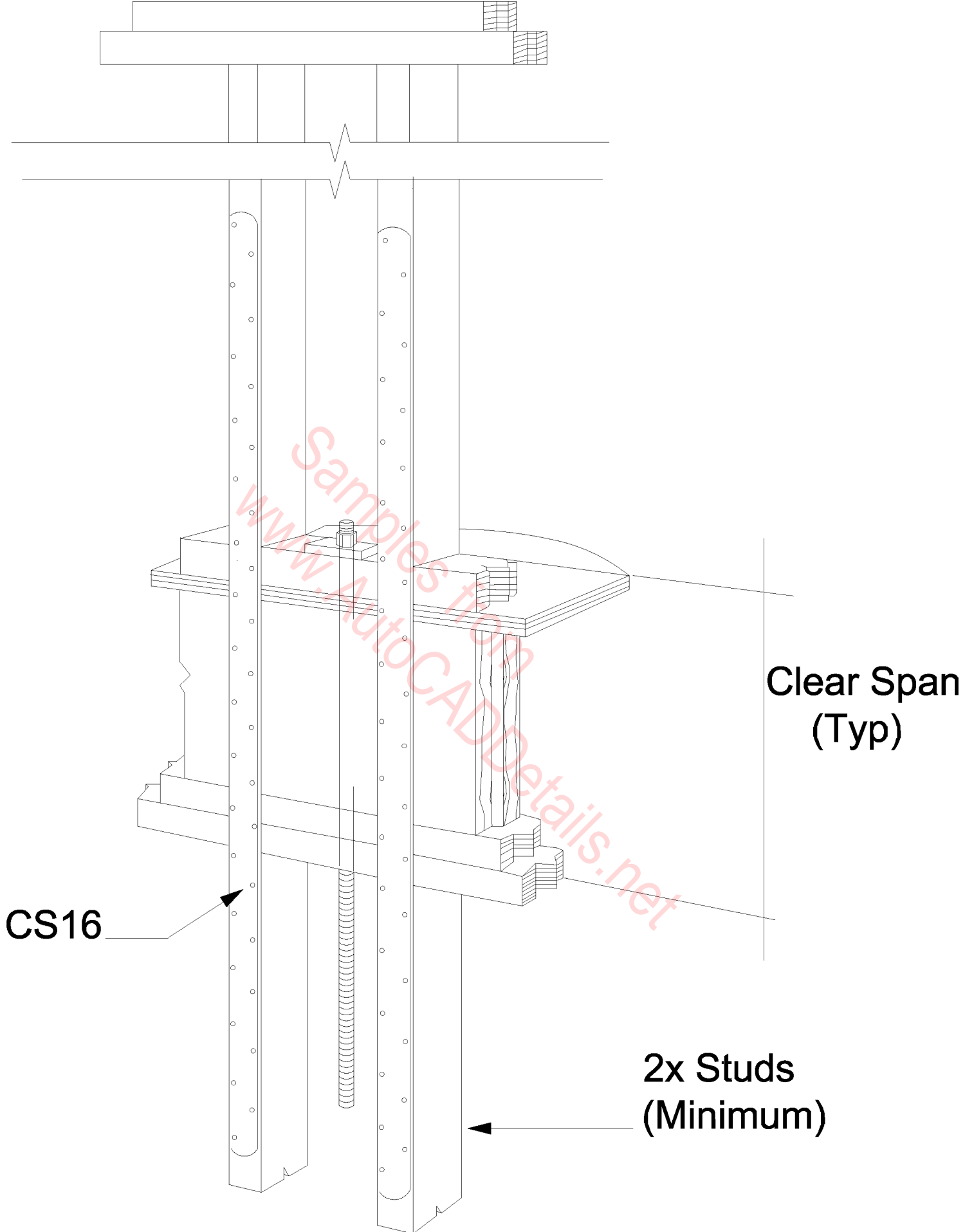

**Alternate Strap Detail A**

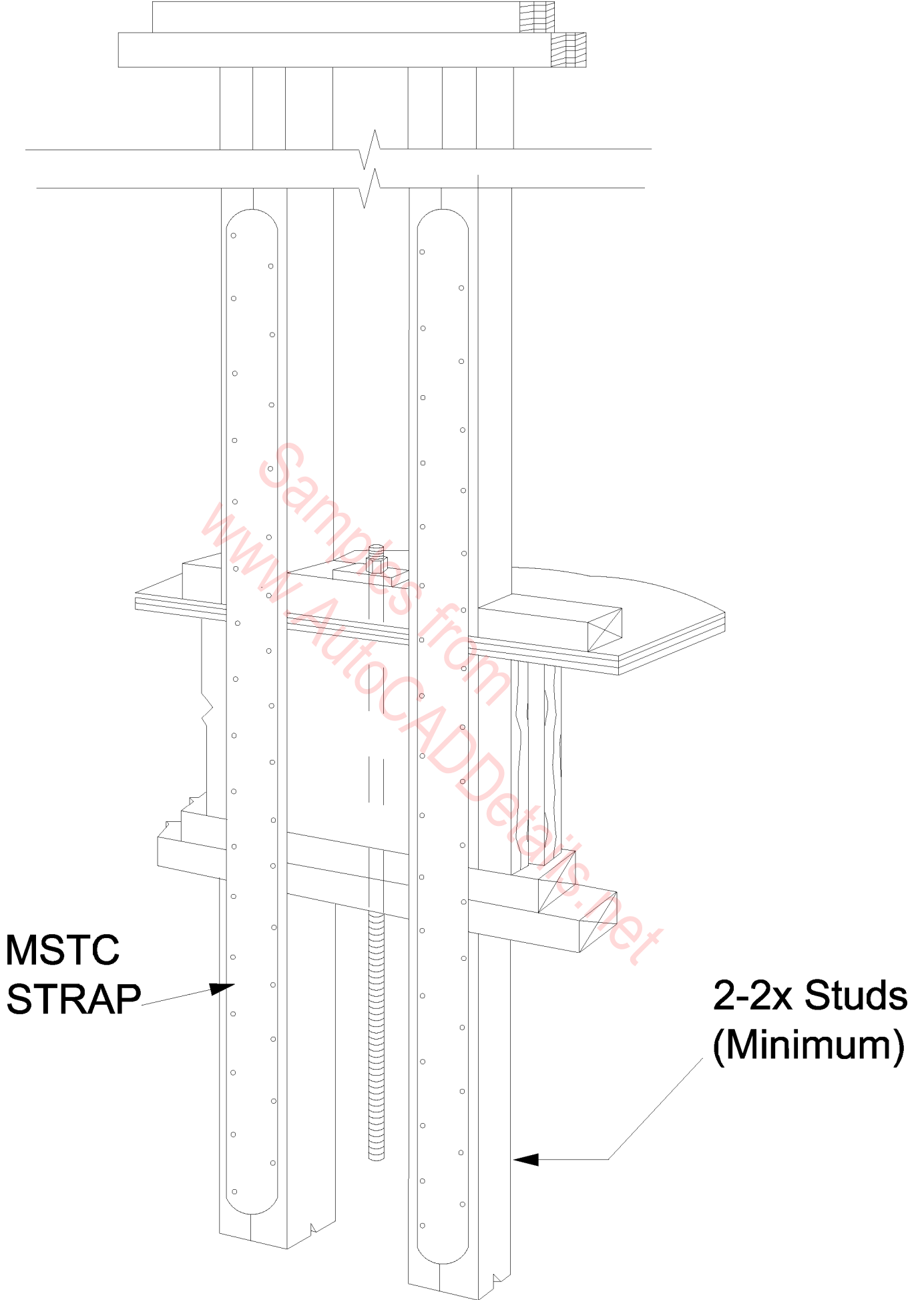

**Alternate Strap Detail B**

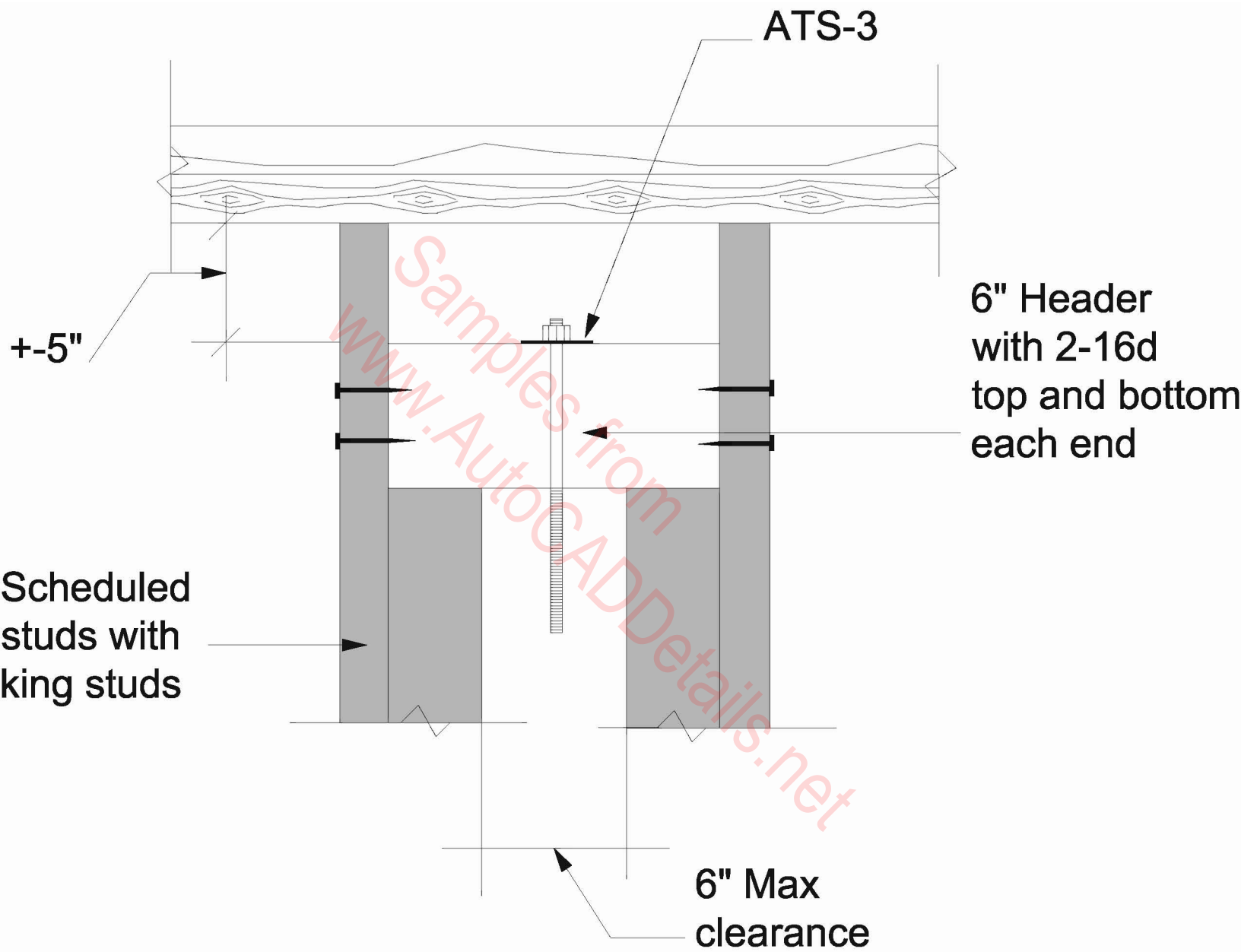

Alternate Top Plate Detail

4 1/4"	1-2x4 or 1-2x6
5 1/4"	1-3x4 or 1-3x6
5 3/4"	2-2x4 or 2-2x6
7 3/4"	2-3x4 or 2-3x6
8 1/4"	1-4x6 or 1-6x6
10"	1-4x8 or 1-6x8
12"	1-4x10 or 1-6x10

Samples from  
www.AutoCADDetails.net

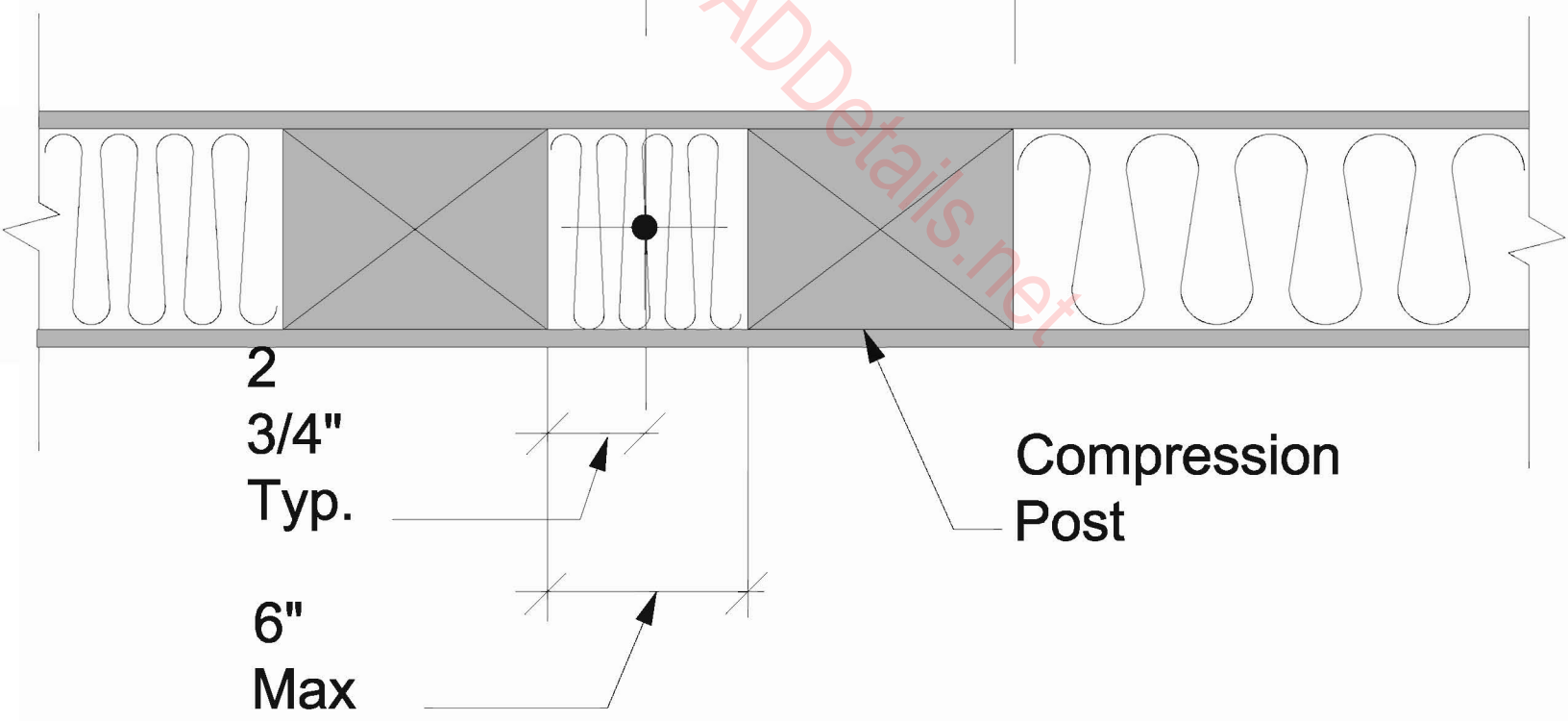

**ANCHOR BOLT**  
**Mid-Wall Location**



- 1-2x4 or 1-2x6=4 1/4"
- 1-3/4 or 1-3x6=5 1/4"
- 2-2x4 or 2-2x6=5 3/4"
- 2-3x4 or 2-3x6=7 3/4"
- 1-4x6 or 1-6x6=8 1/4"
- 1-4x8 or 1-6x8=10"
- 1-4x10 or 1-6x10=12"

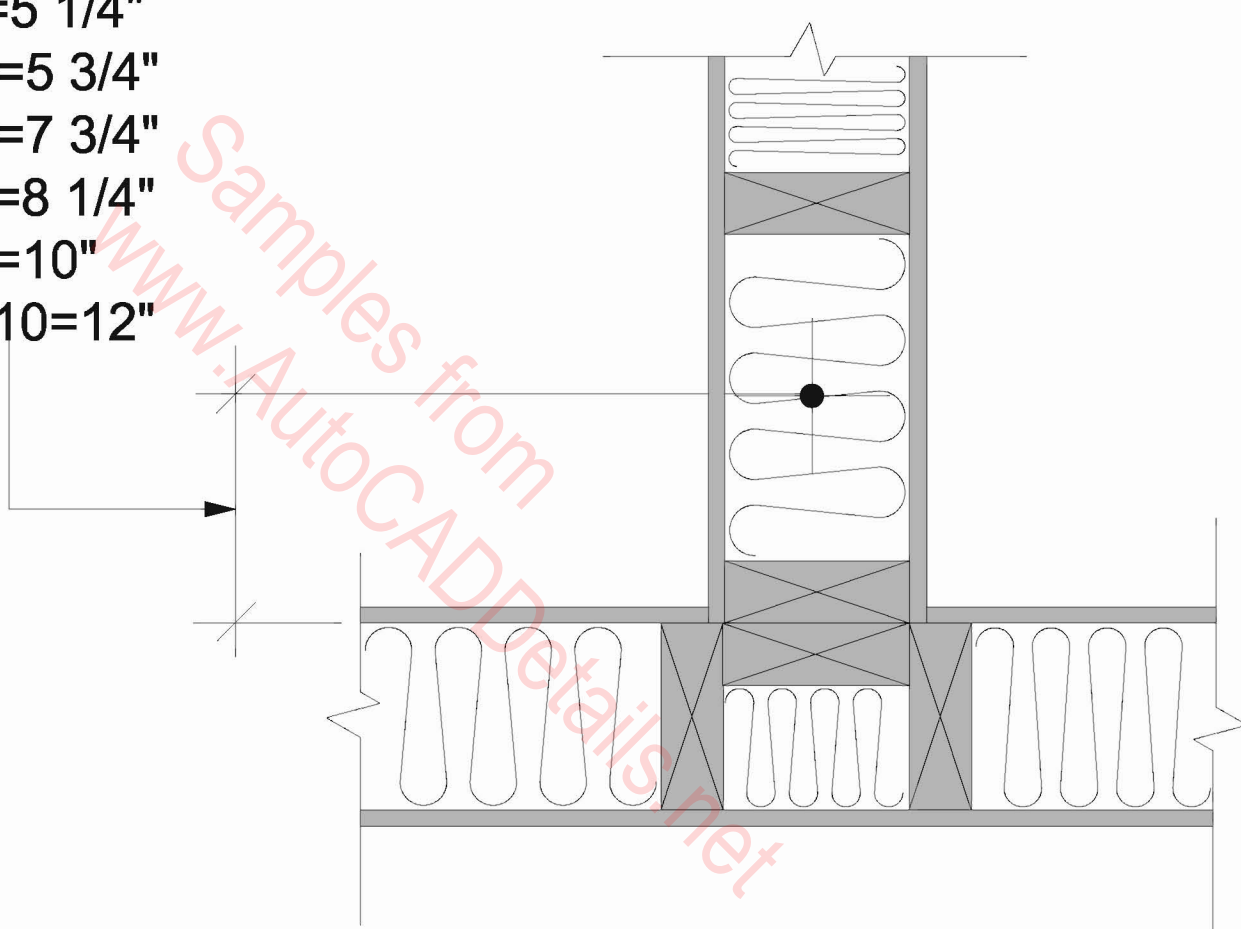

**ANCHOR BOLT**  
**Perpendicular-To-Wall Location**

1/8" Maximum Hole

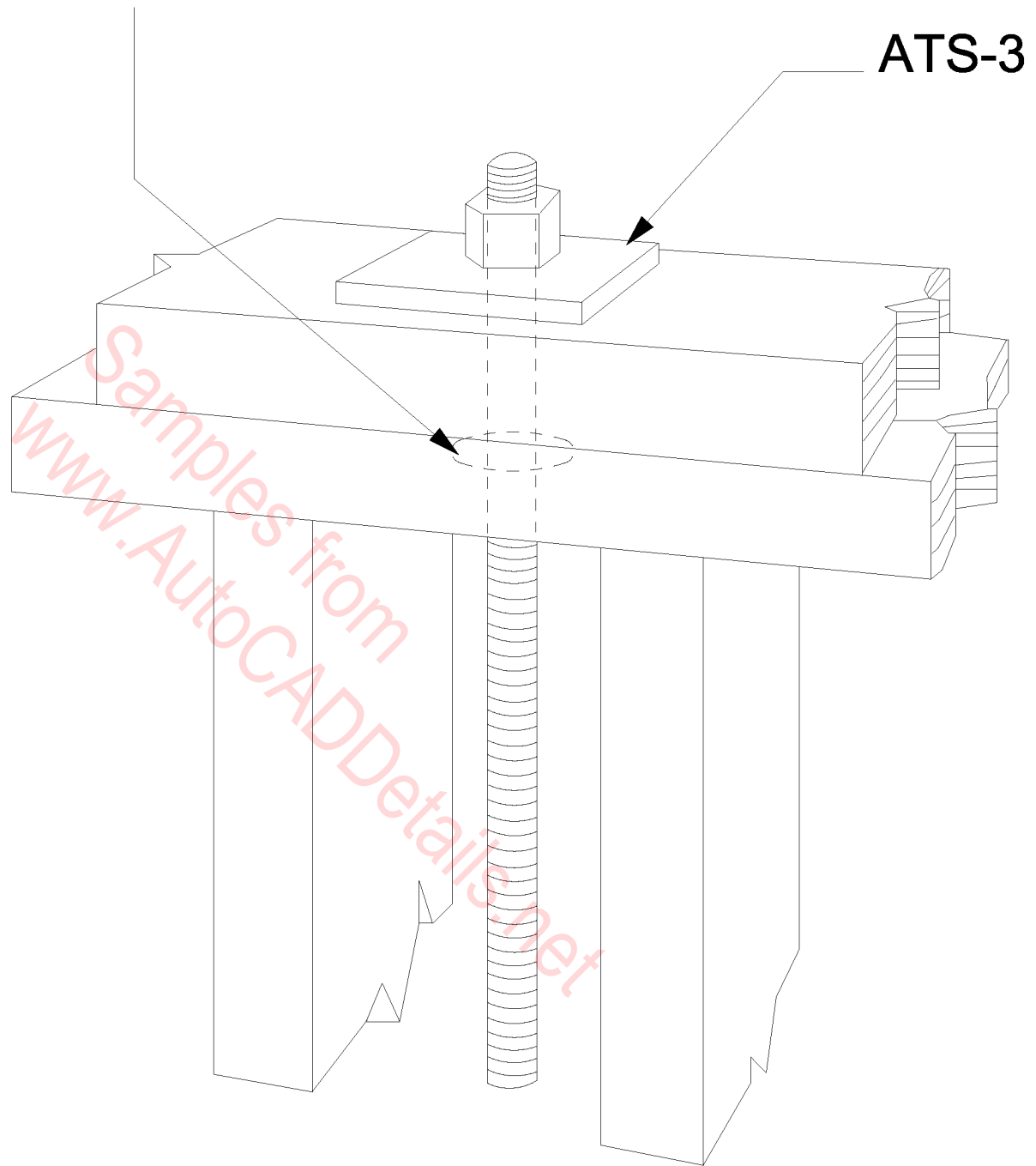

Bearing plate at double top plate  
No splice in the top plate permitted  
within 8" of the rod.

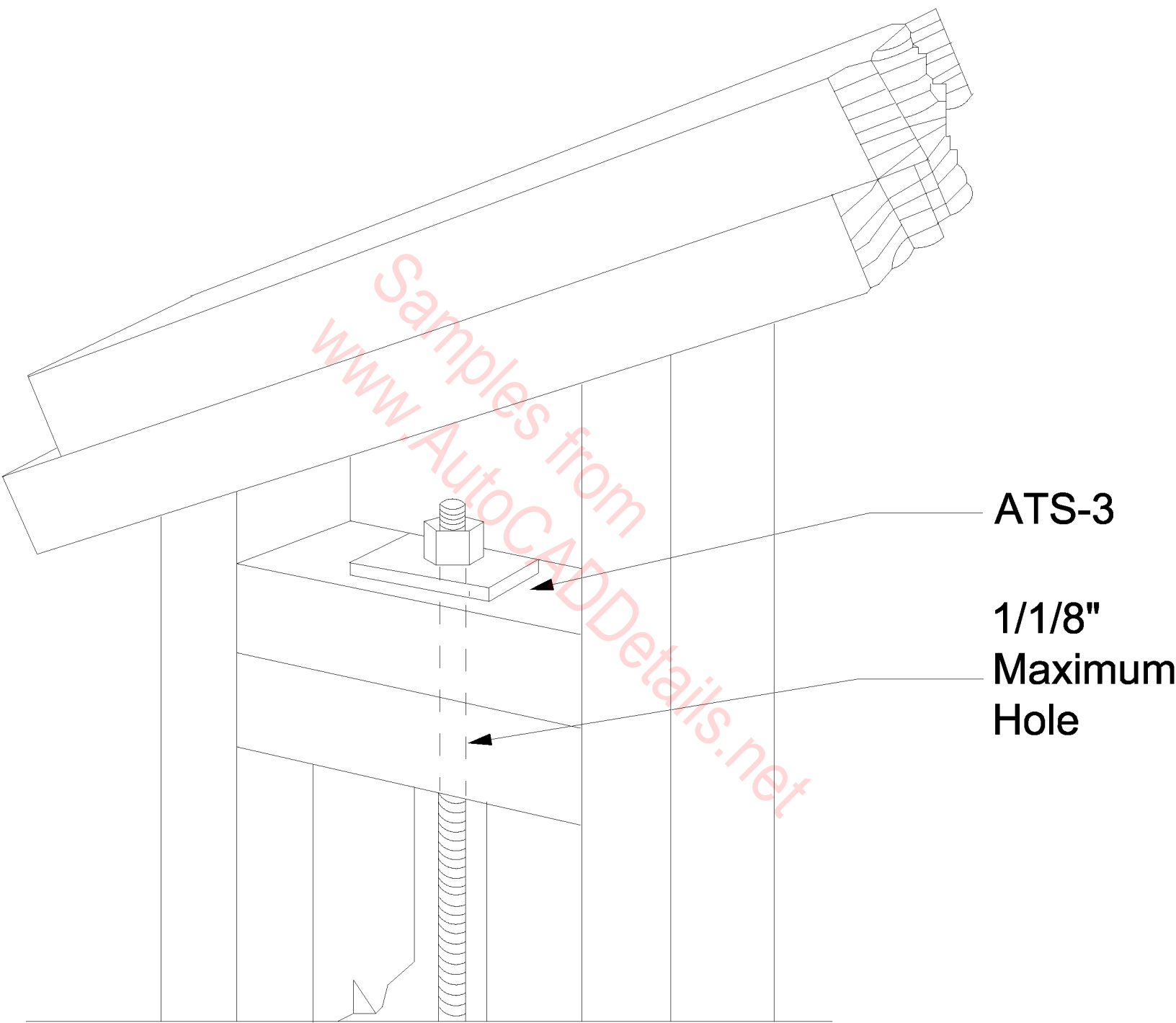

**Bearing Plate Detail at a Rake Wall**

- 1-2x4 or 1-2x6 = 4 1/4"
- 1-3x4 or 1-3x6 = 5 1/4"
- 2-2x4 or 2-2x6 = 5 3/4"
- 2-3x4 or 2-3x6 = 7 3/4"
- 1-4x6 or 1-6x6 = 8 1/4"
- 1-4x8 or 1-6x8 = 10"
- 1-4x10 or 1-6x10 = 12"

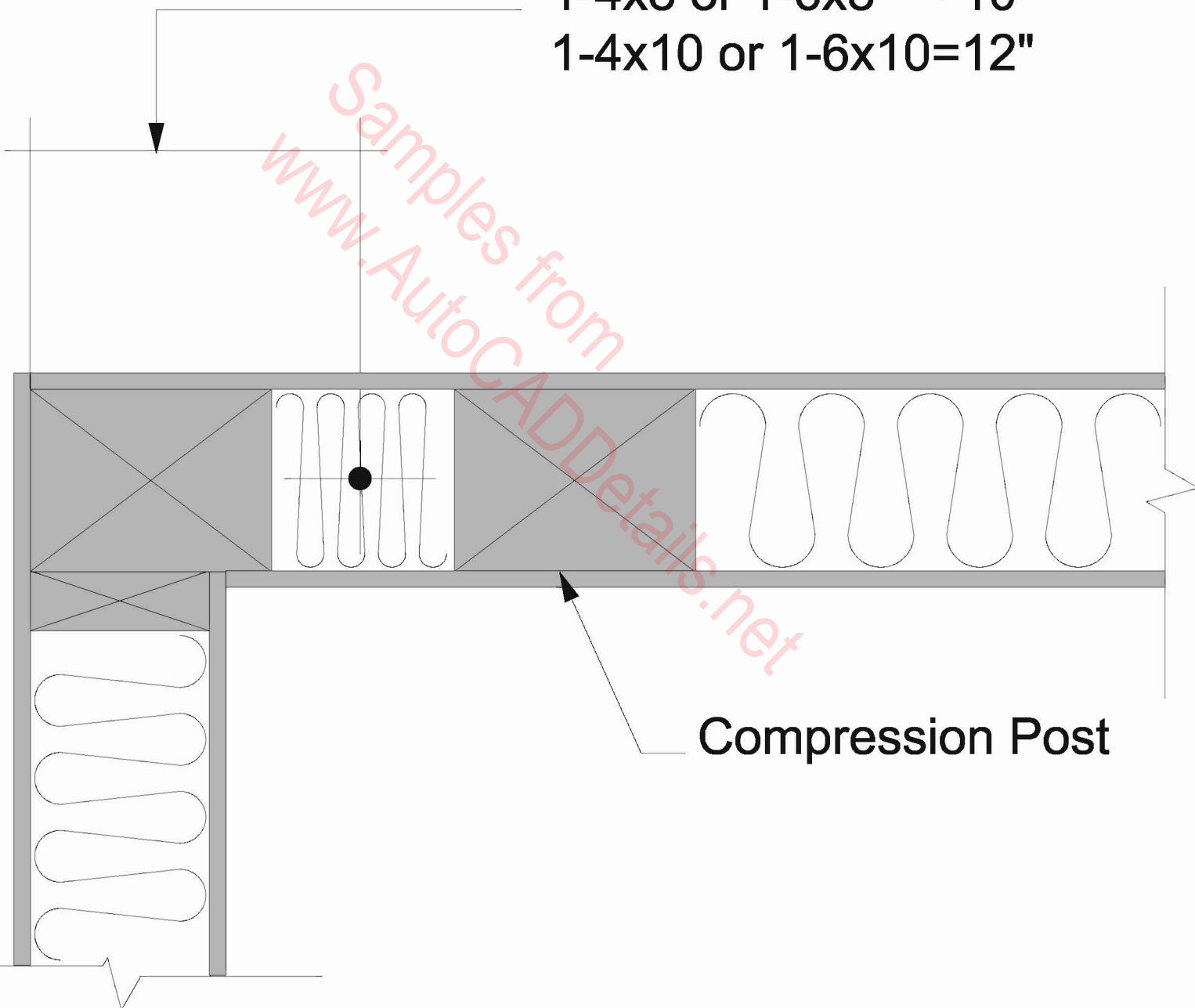

Compression Post

## Corner Installation

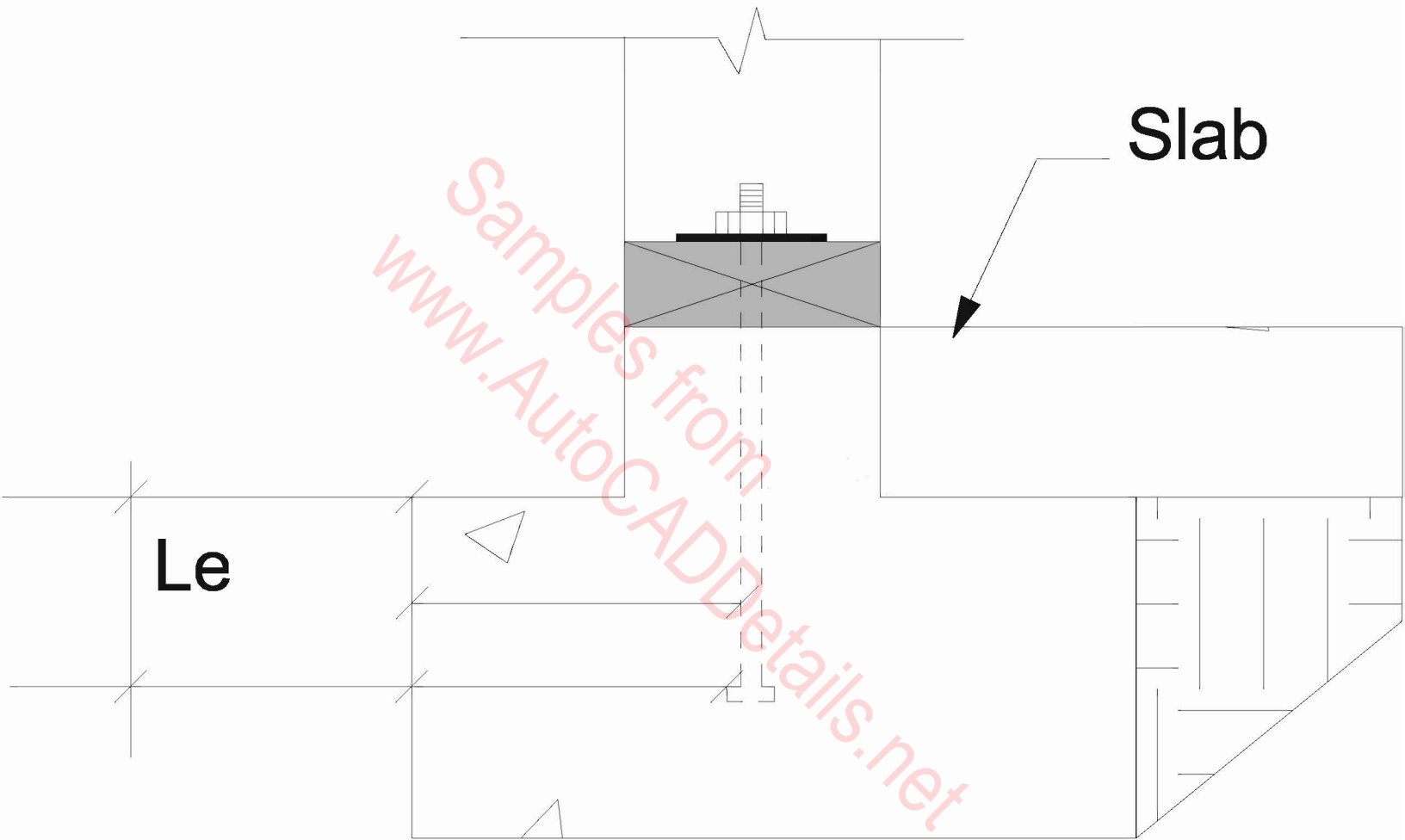

**Elevation View**

2x pressure-treated  
sill plate

1/2" min.diameter  
anchor bolt with washer

Masonry  
foundation

7" Min. embedment

6 FT.  
Max.

WITHIN 12 INCHES  
OF END OF EACH  
PIECE

MINIMUM OF  
TWO BOLTS  
PER PIECE

UNDERFLOOR  
ACCESS OPENING  
18" X 24" MIN.

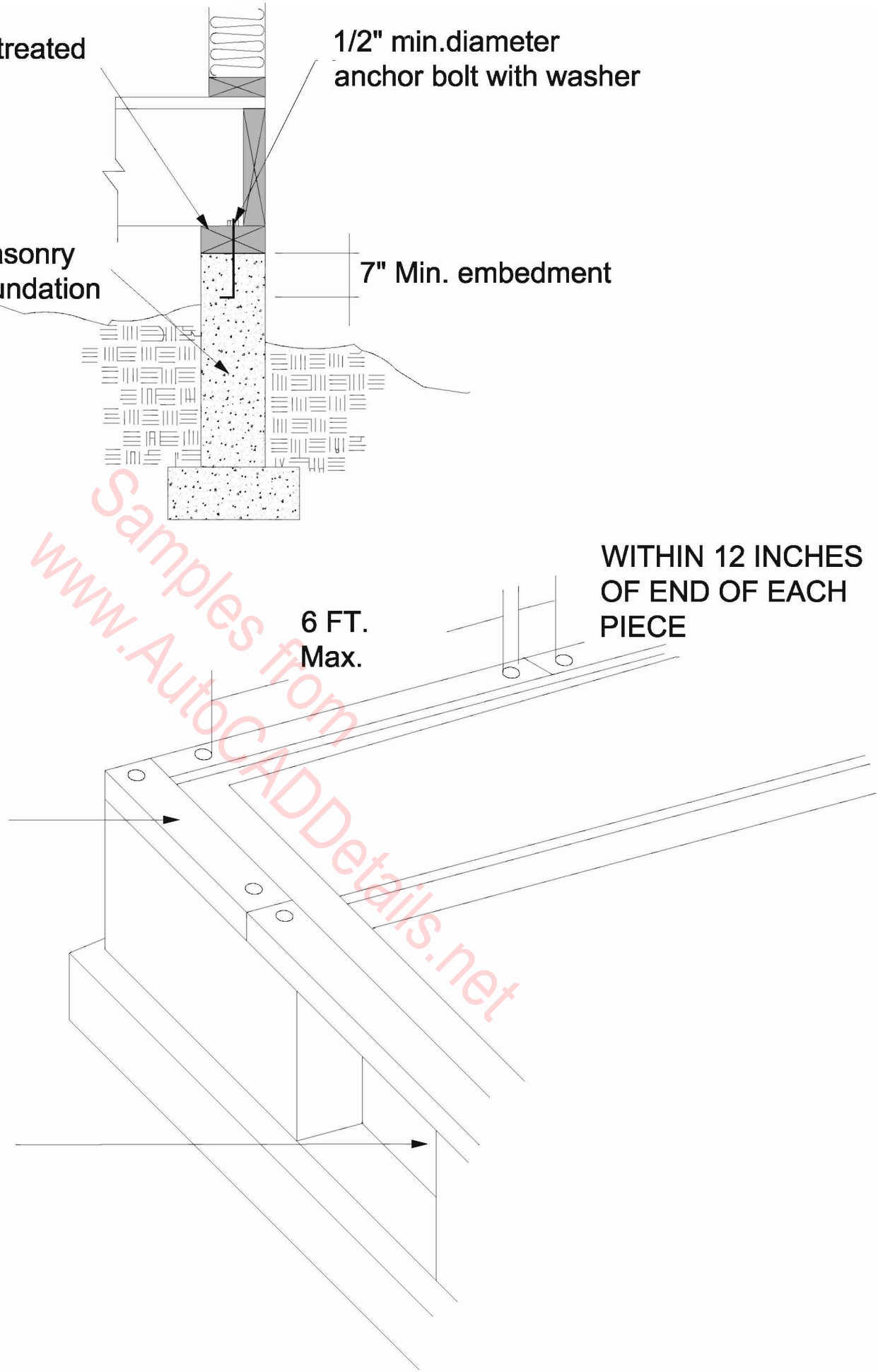

Foundation Plates or Sills  
(Code Requirement 2320.6 UBC)

Finish Underlay  
and Subfloor

2X BLK'G  
@ Bearing

Bearing FLR Beam  
(See Plans for size)

Simpson BC Series  
Conn. Post To Beam

Post (See Plan  
For Size/Spacing)

Tie Posts @ Base W/2x4  
When Ht. Exceeds 3'

Concrete Footing

# JOIST FLOOR CONNECTION

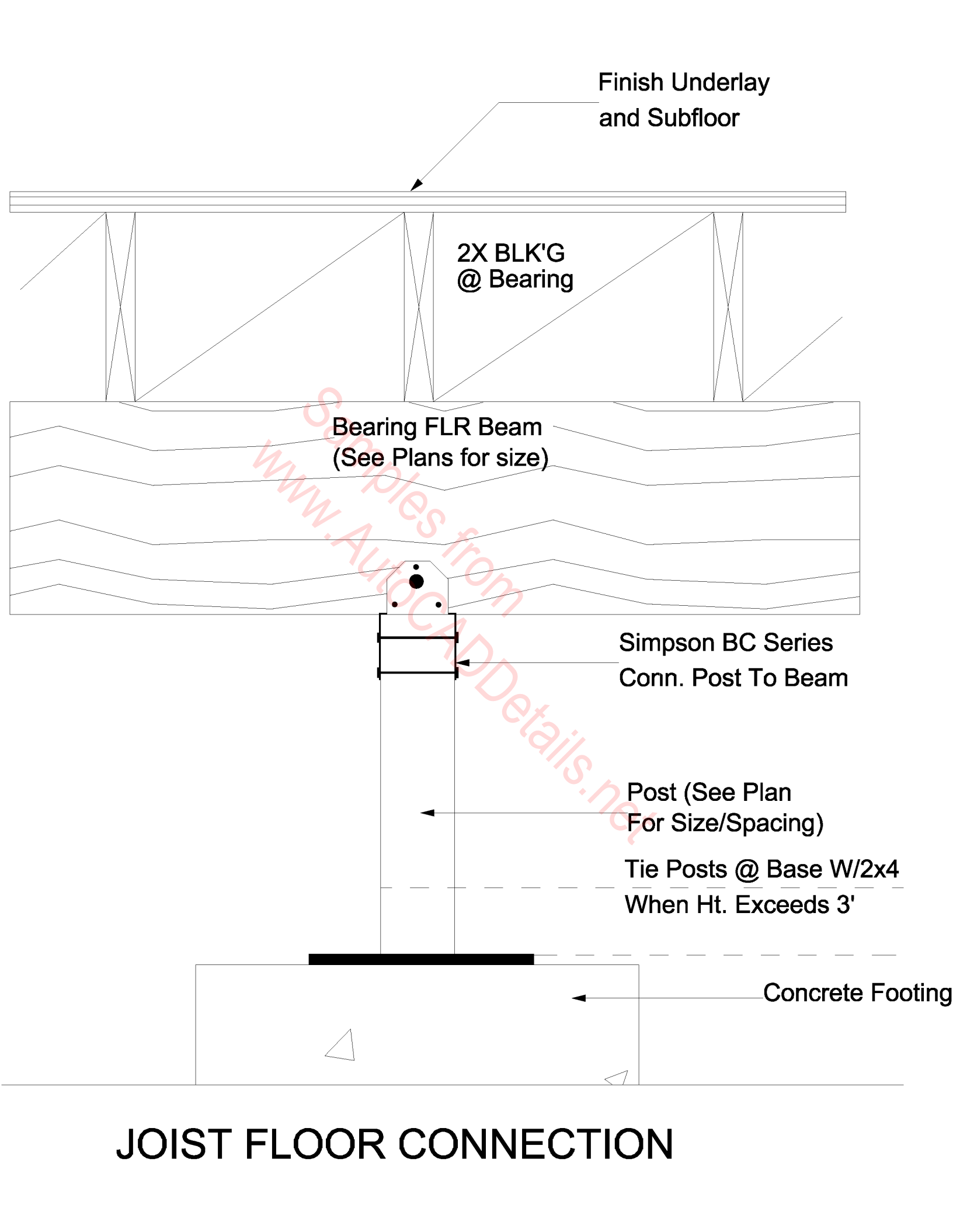

TDS13

Level 1-----11,390#

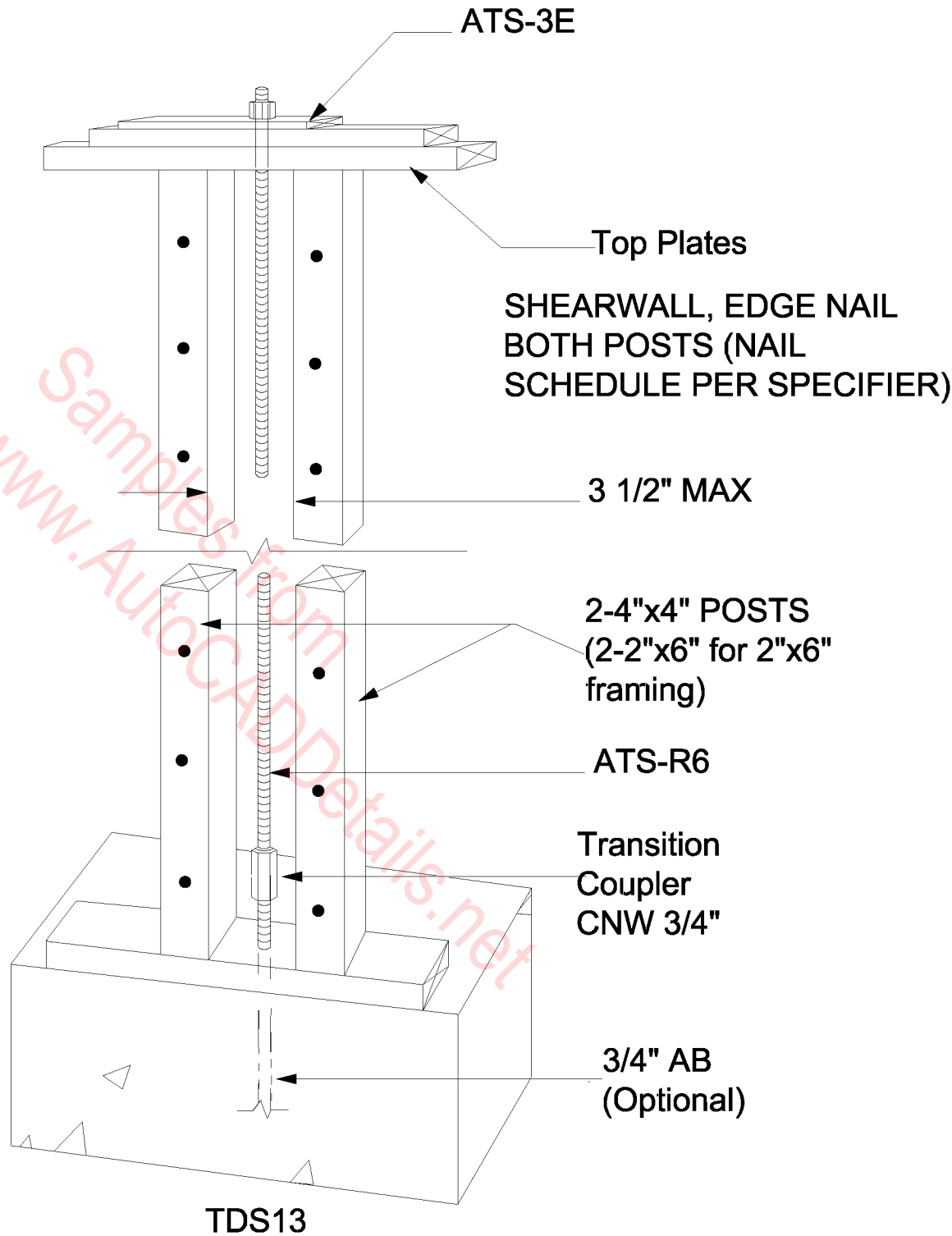

One Story TDS Model



TDS13

Level 1-----11,390#

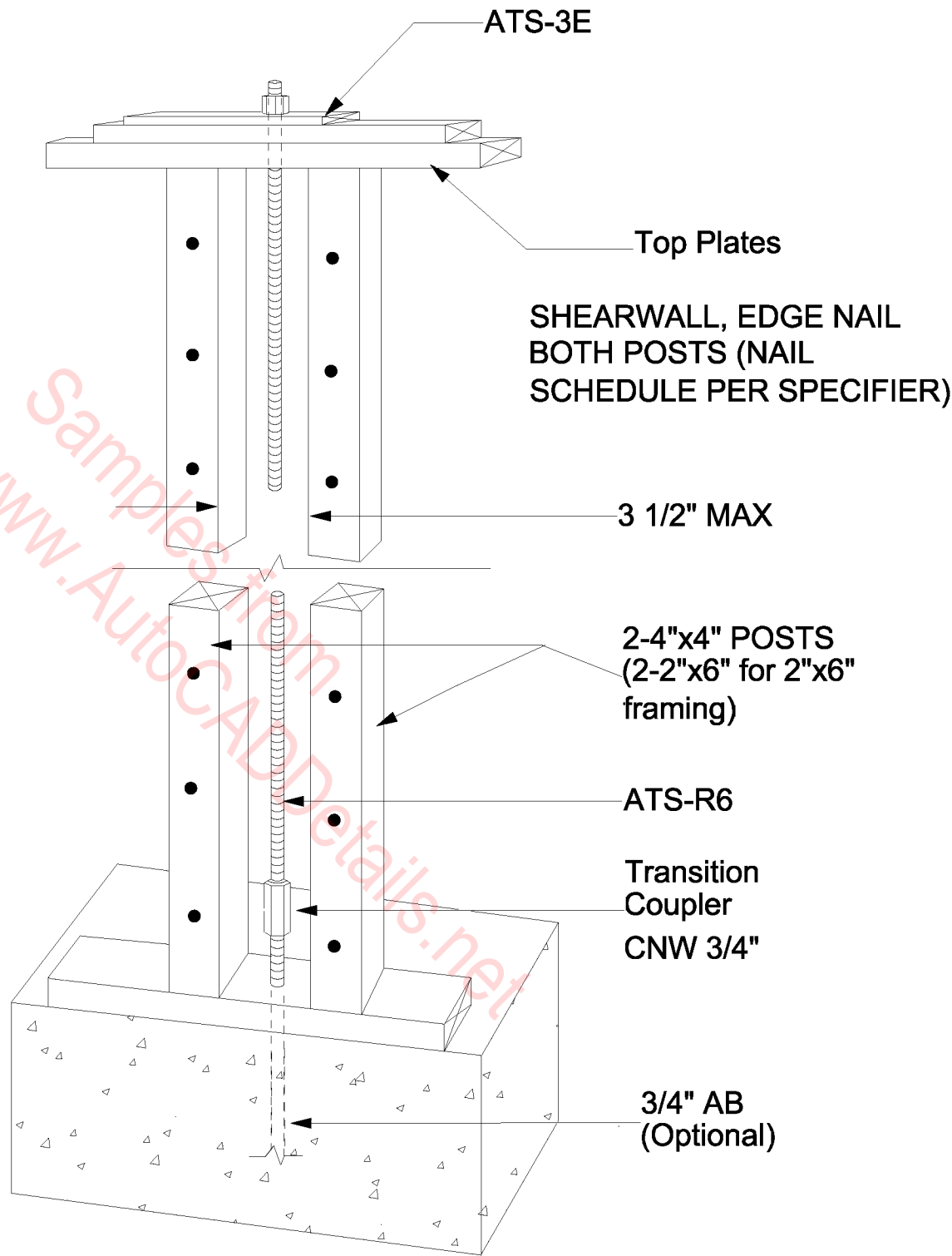

TDS13

One Story TDS Model

TDS15
Level 1-----20,250 #

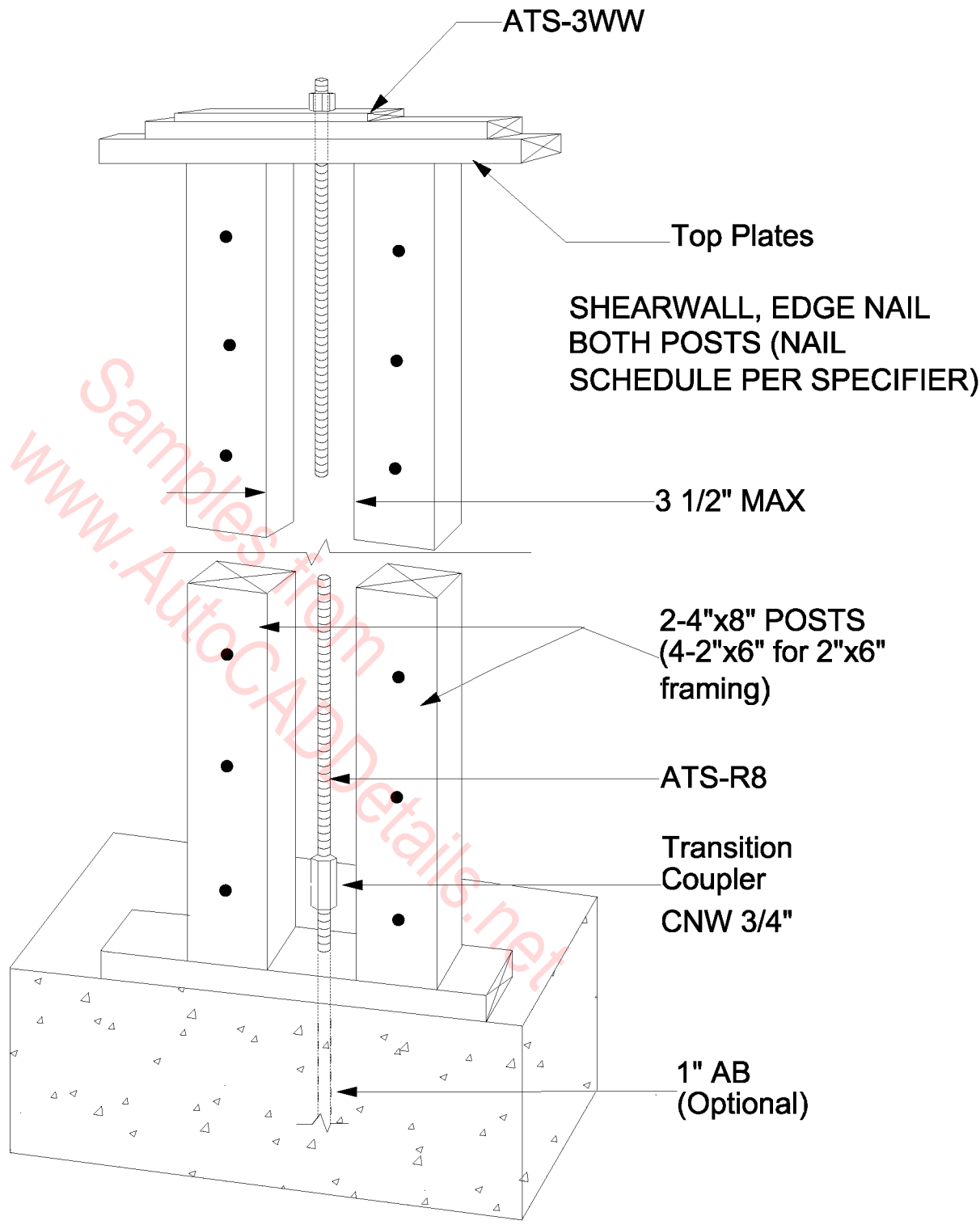

TDS15

### One Story TDS Model

TDS11
Level 1-----5,060 #

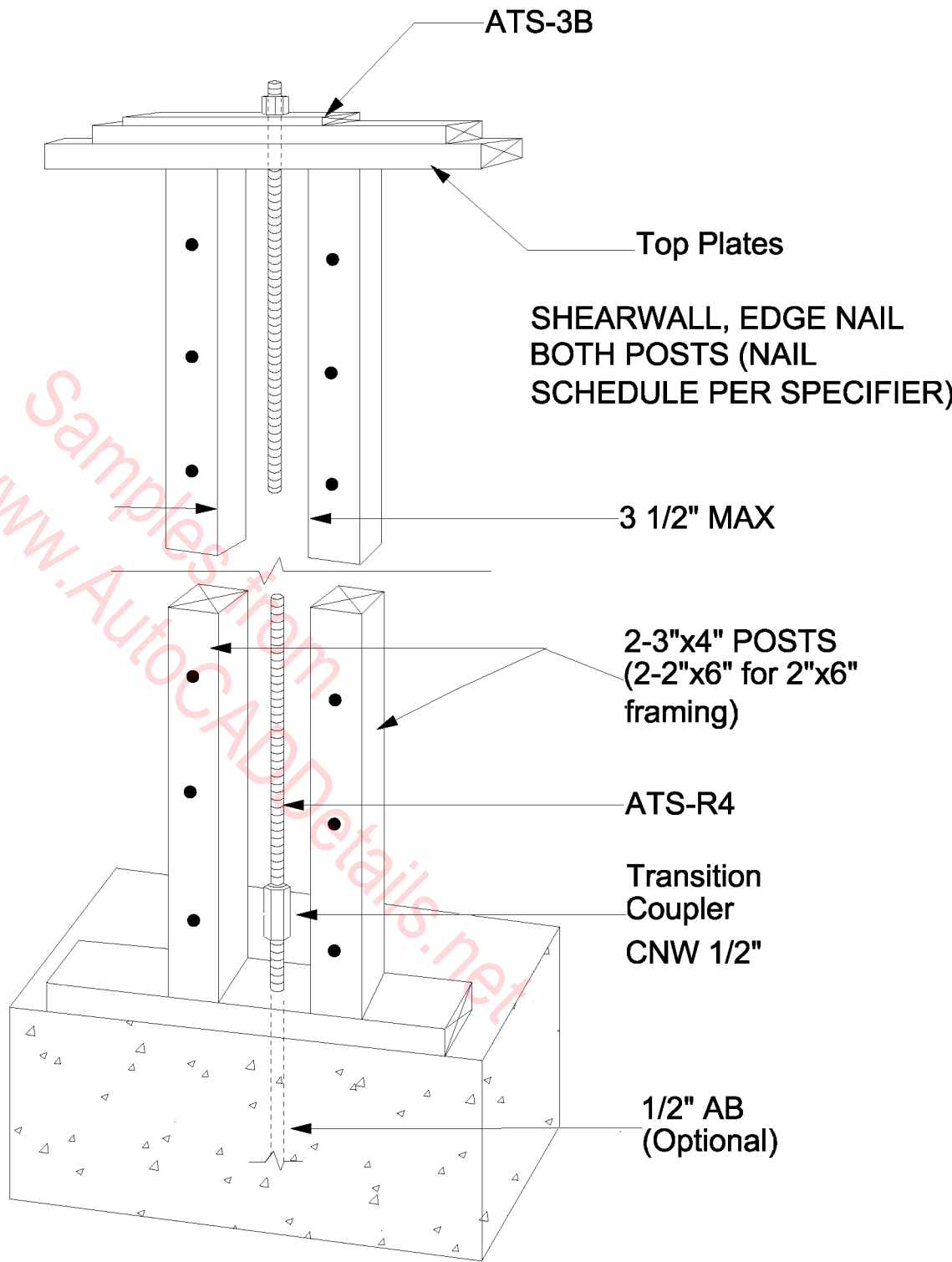

TDS11

### One Story TDS Model

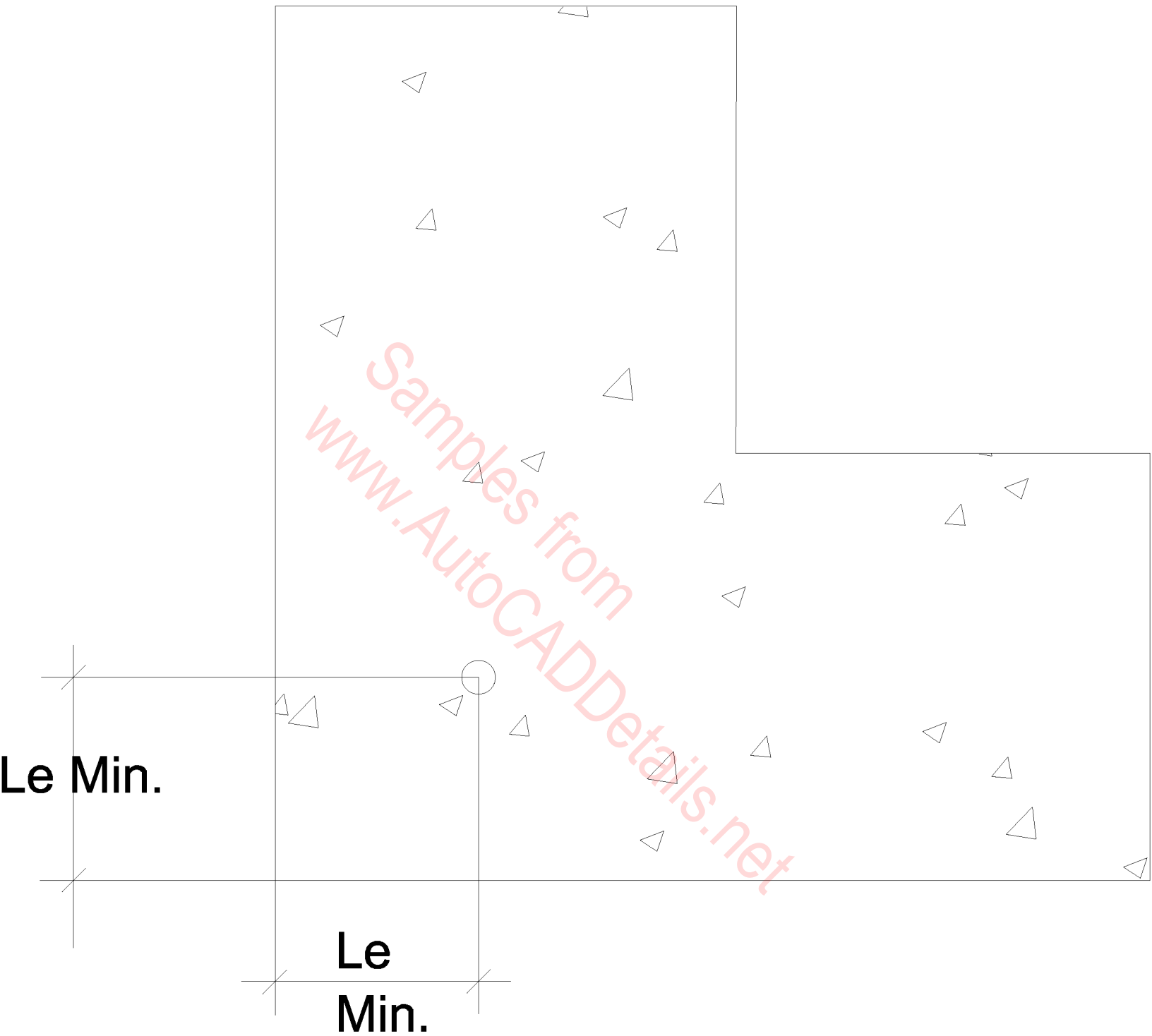

**Plan View--Anchor Bolt Location  
(See 1997 UBC, Section 1923.3.2  
Or you local code requirements)**

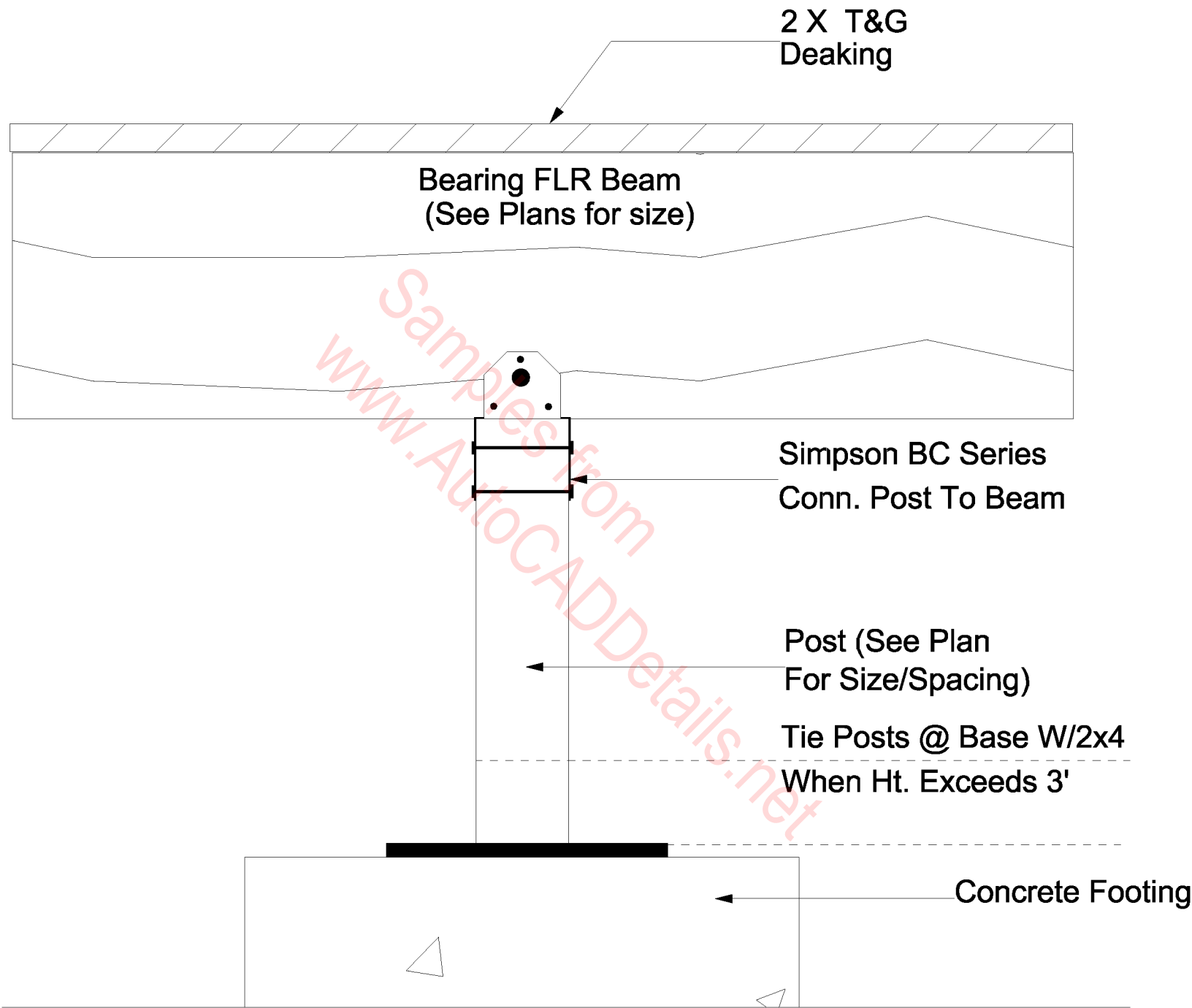

# POST & BEAM CONNECTION

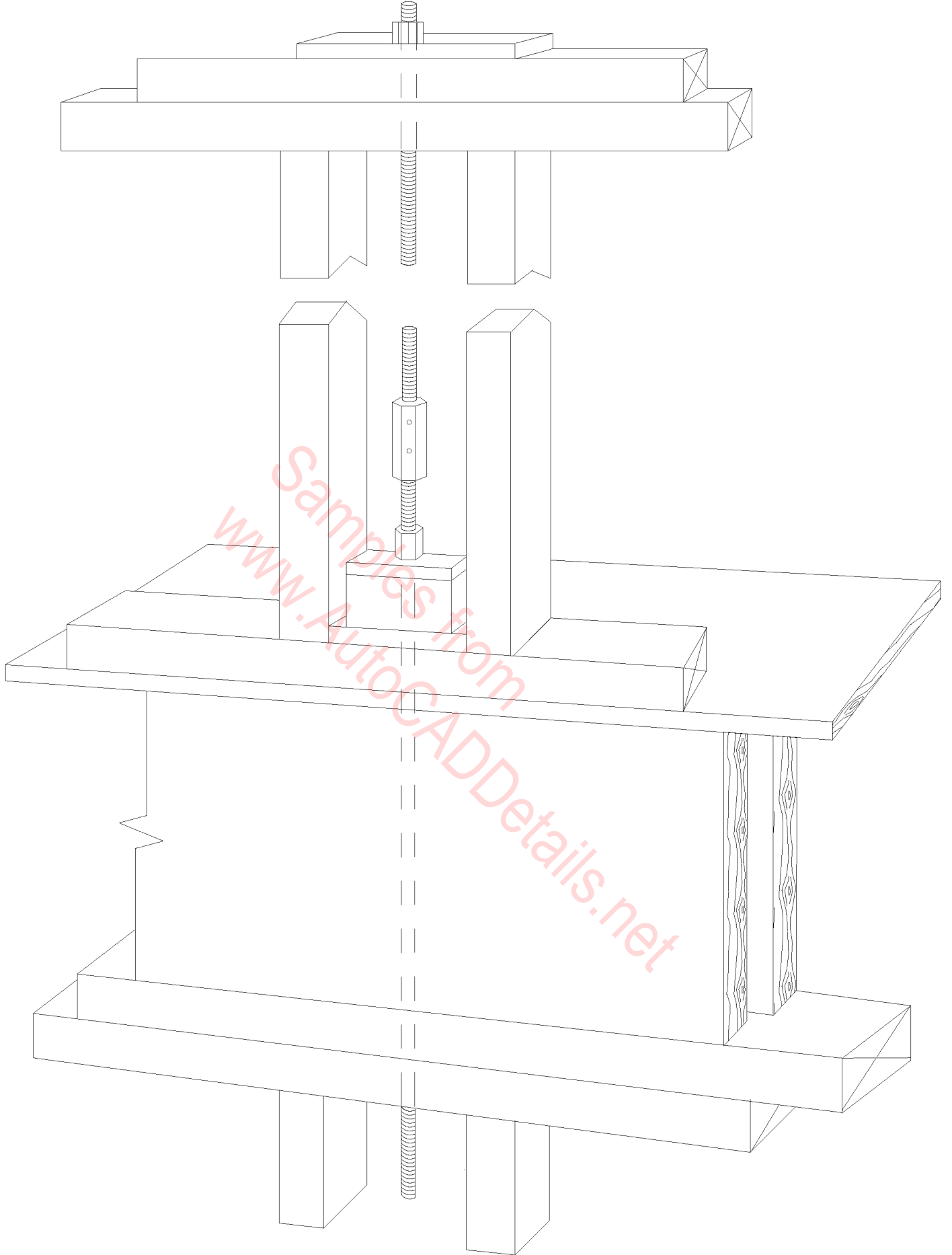

**Standard Detail  
(Alternate Top Story Installation)**

1/2 TDS2-Series  
Component

3/16"

Steel Beam

STEEL Beam Detail

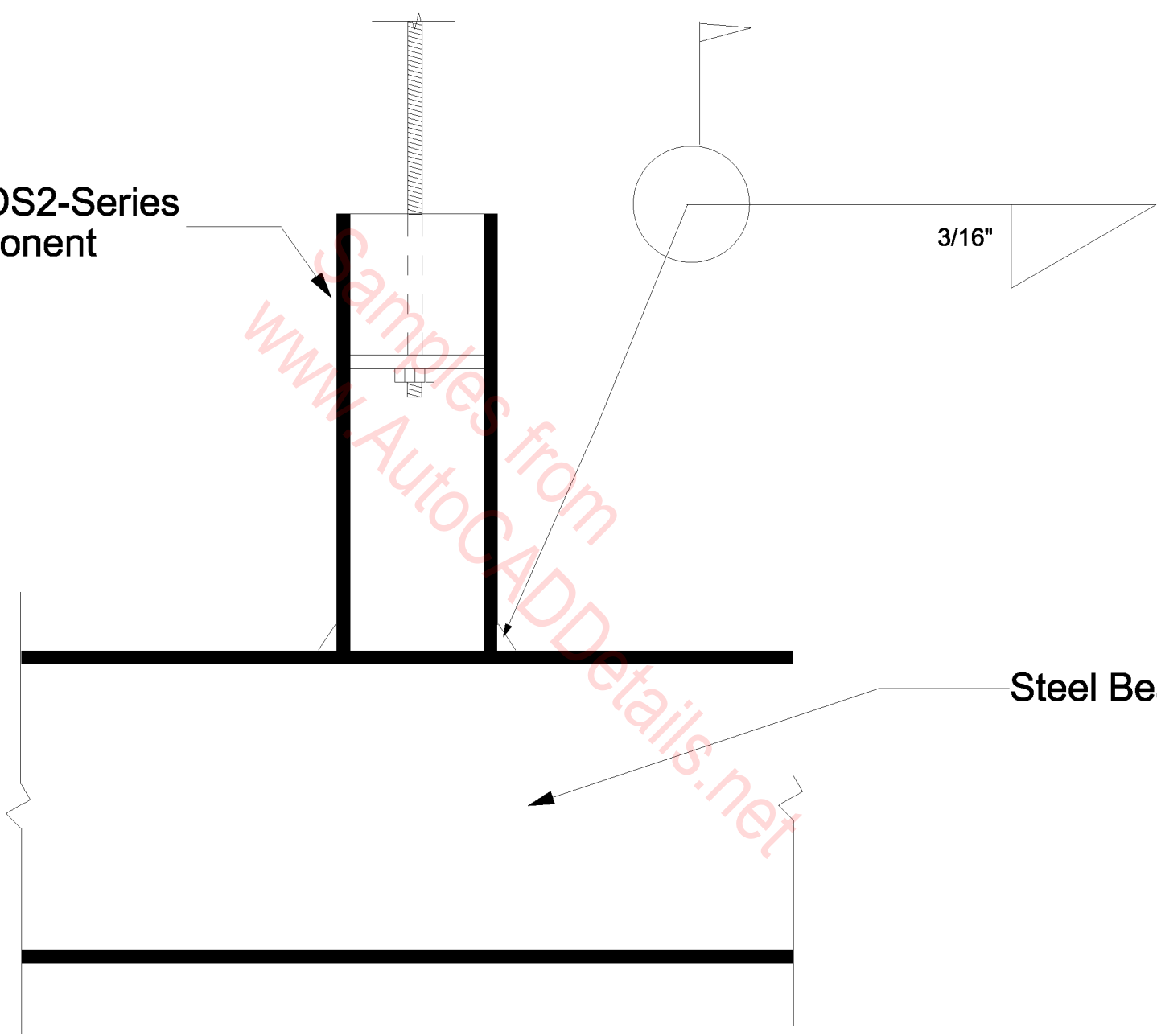

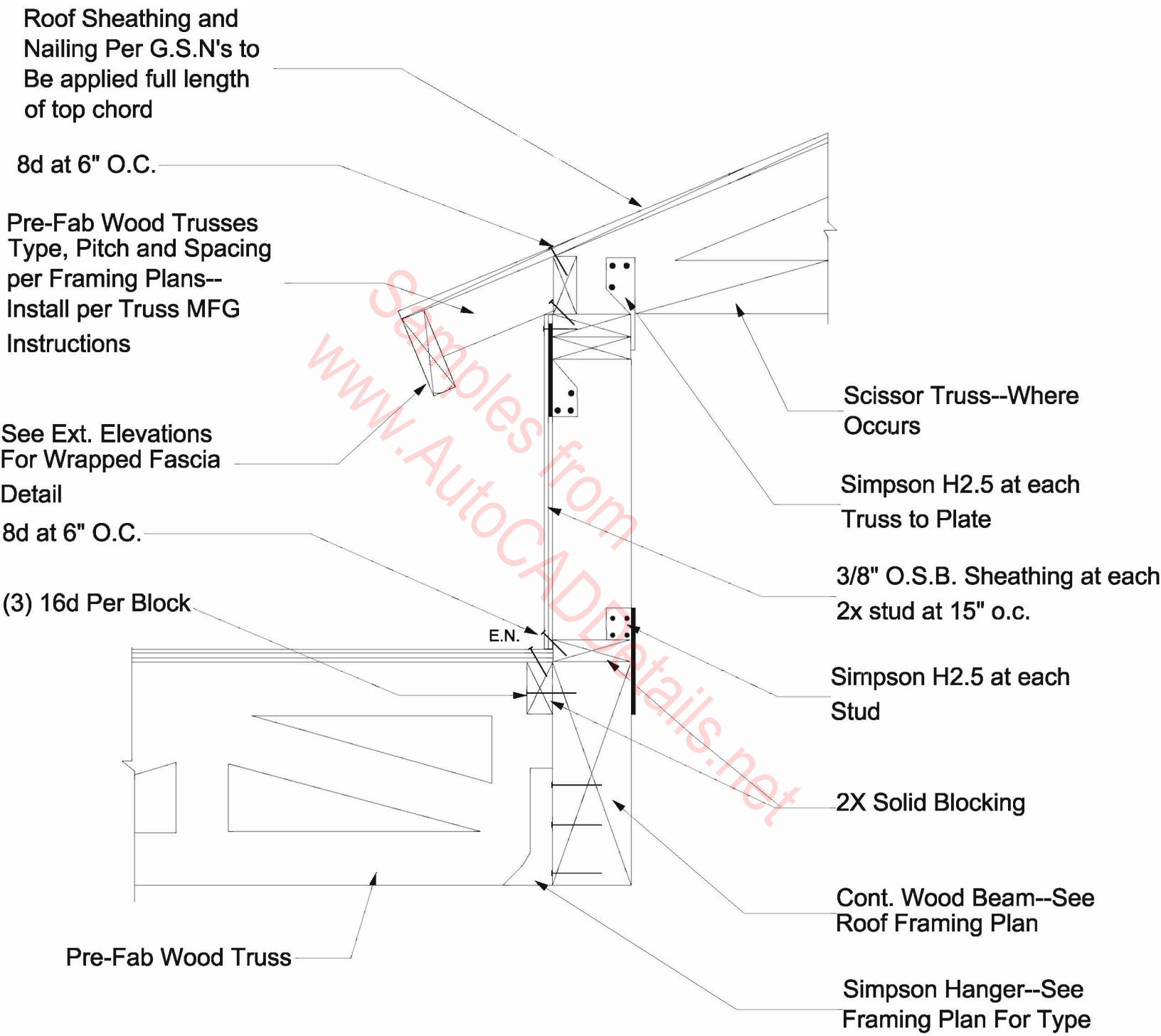

## TRUSS BEARING at BEAM



TDS21

Level 1----7,900 #  
Level 2----5,060 #

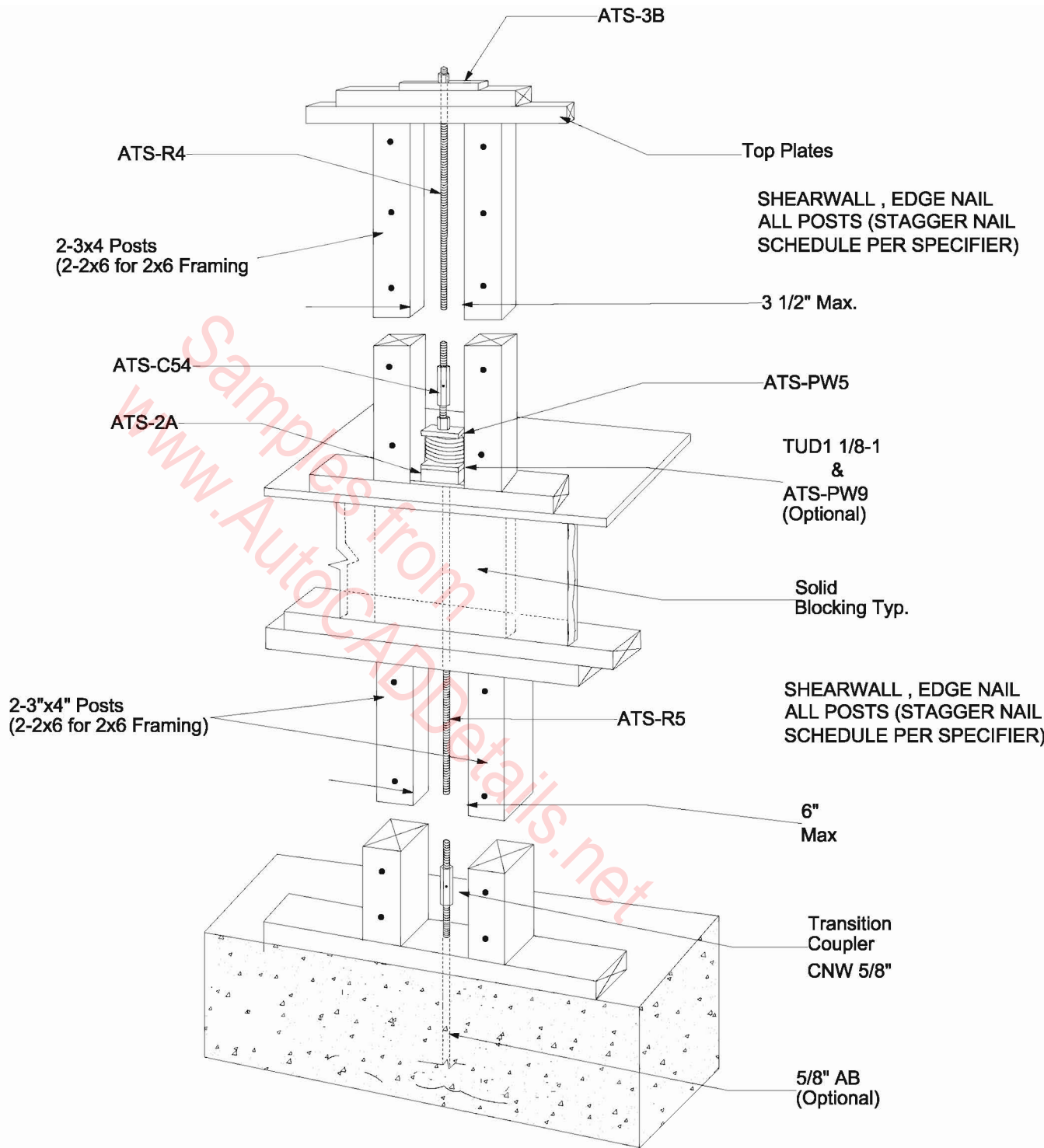

TDS21

Two Story TDS Model--TDS21

TDS23

Level 1-----14,000 #

Level 2-----7,900 #

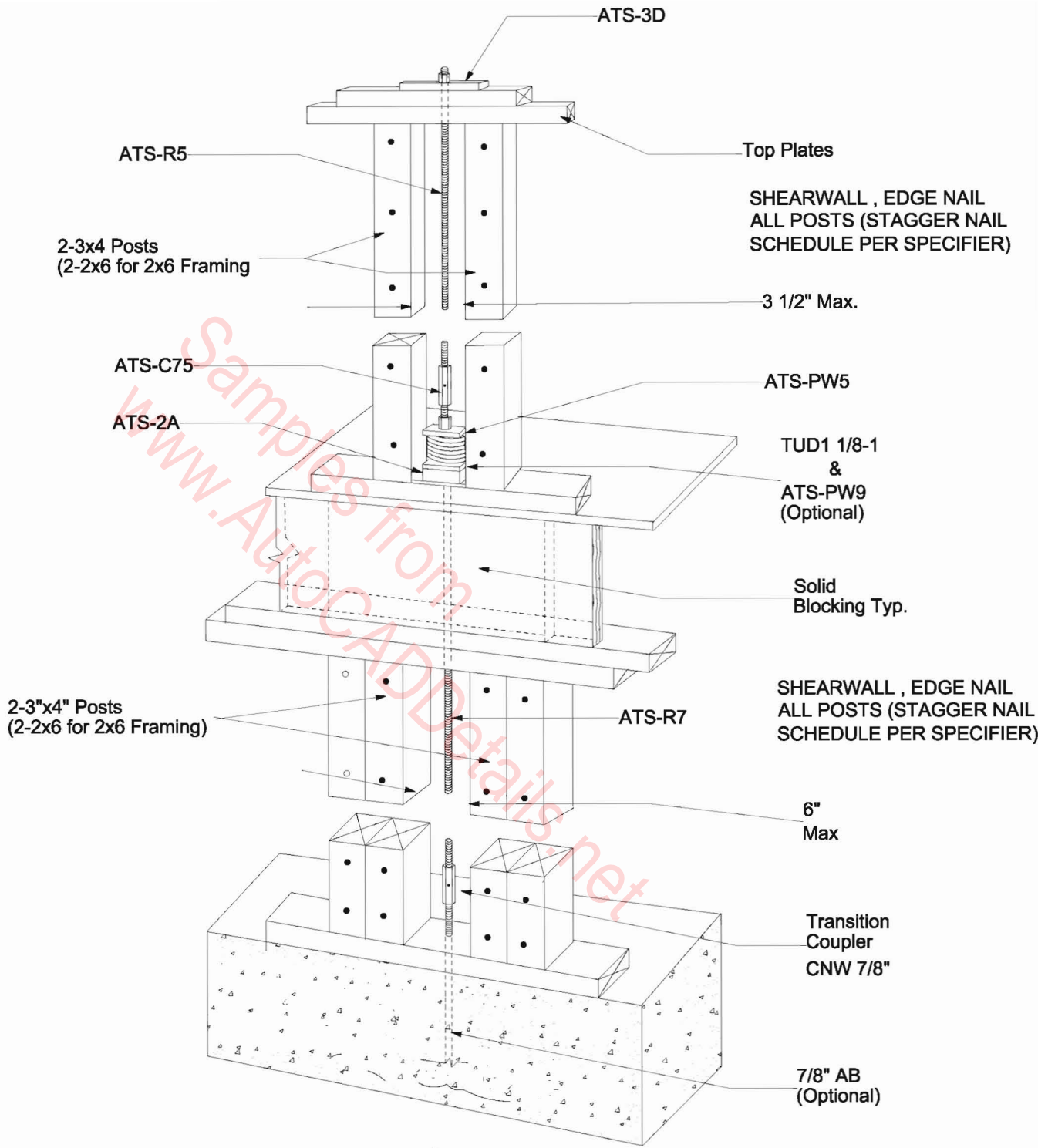

TDS23

Two Story TDS Model--TDS23

Simpson MST Strap W/Min.  
4-16d Per End

Simpson MST Strap W/ Min.  
4-16d per End

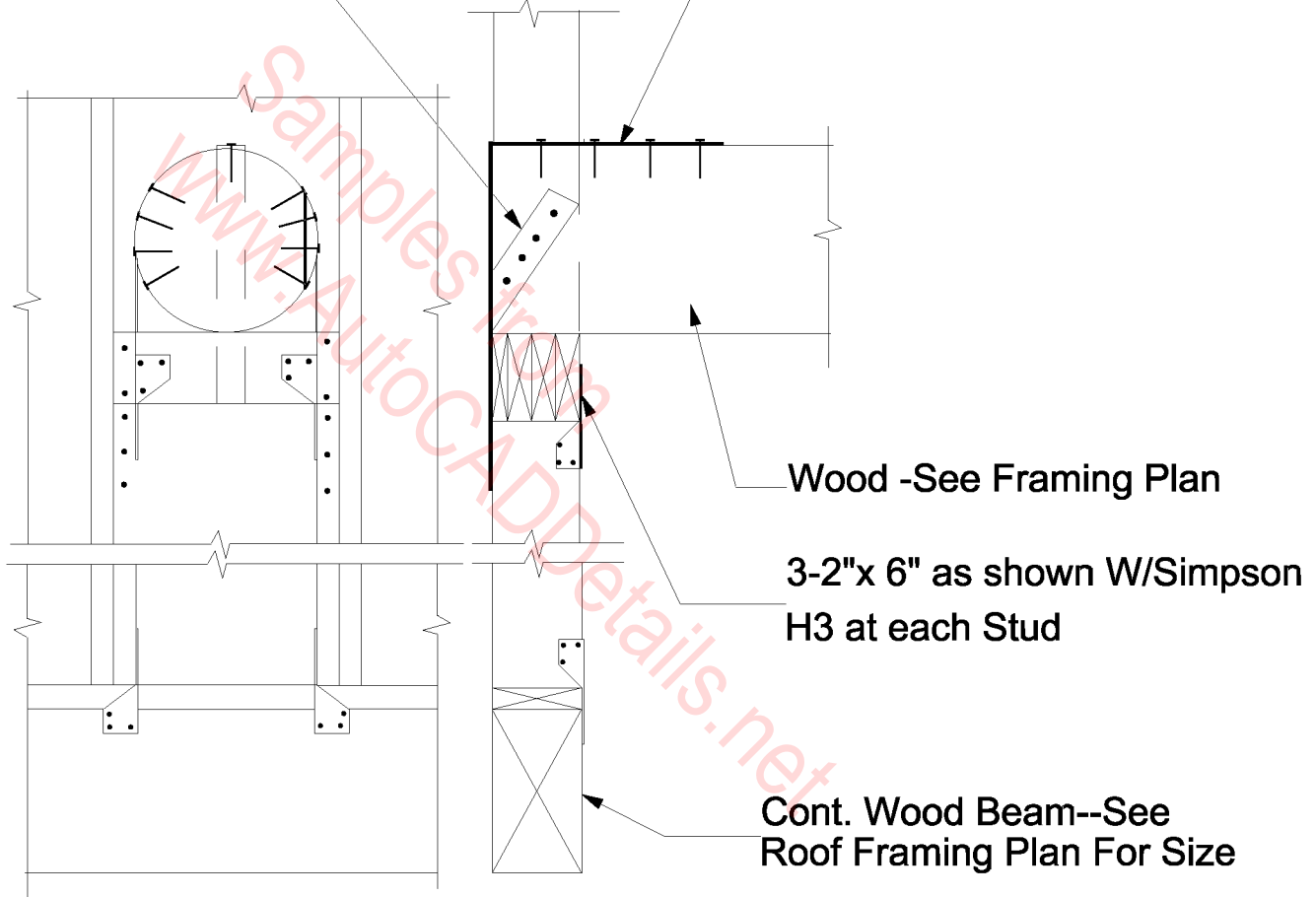

## VIGA BEARING at WALL

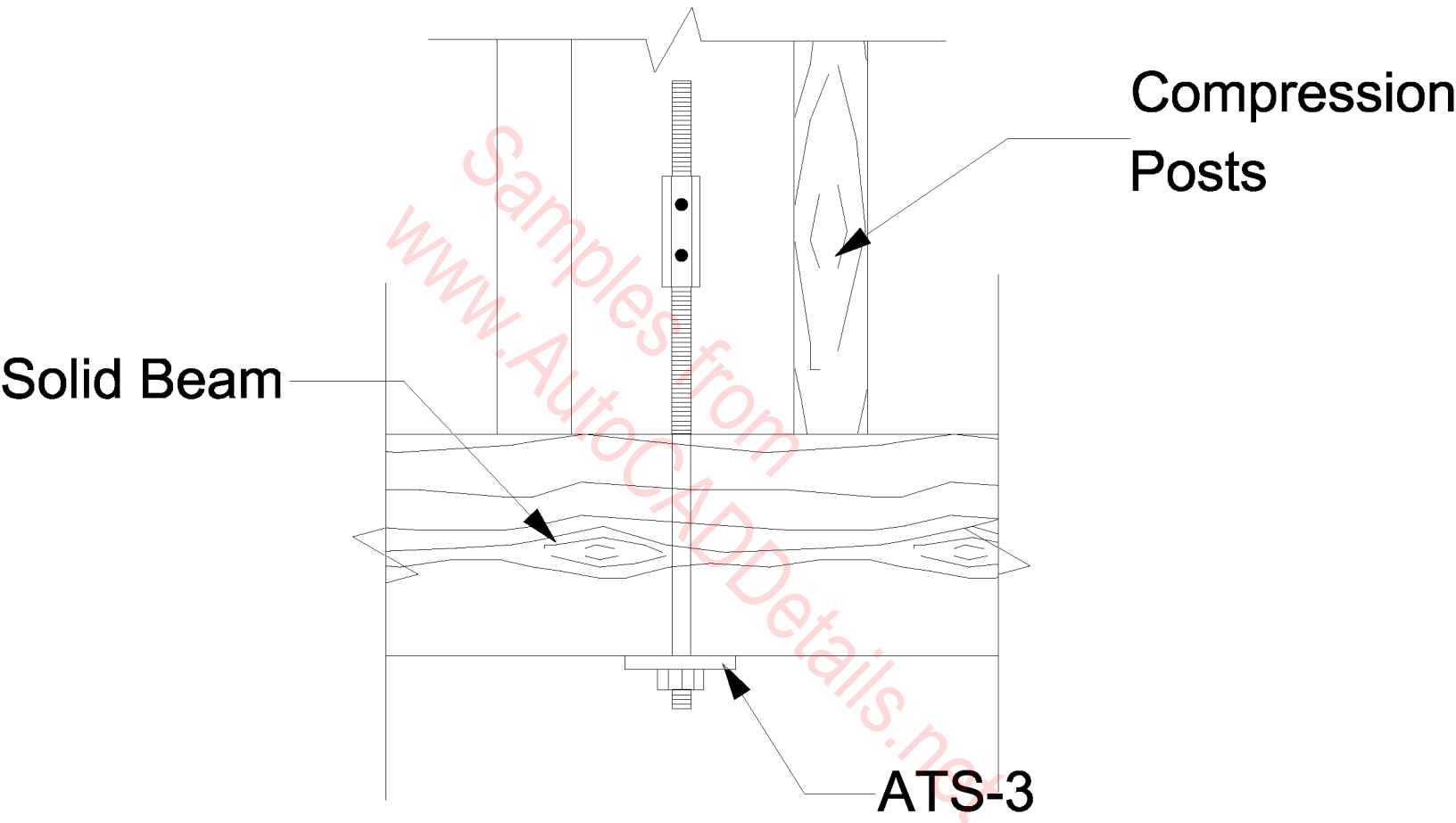

**Wood Beam Detail**

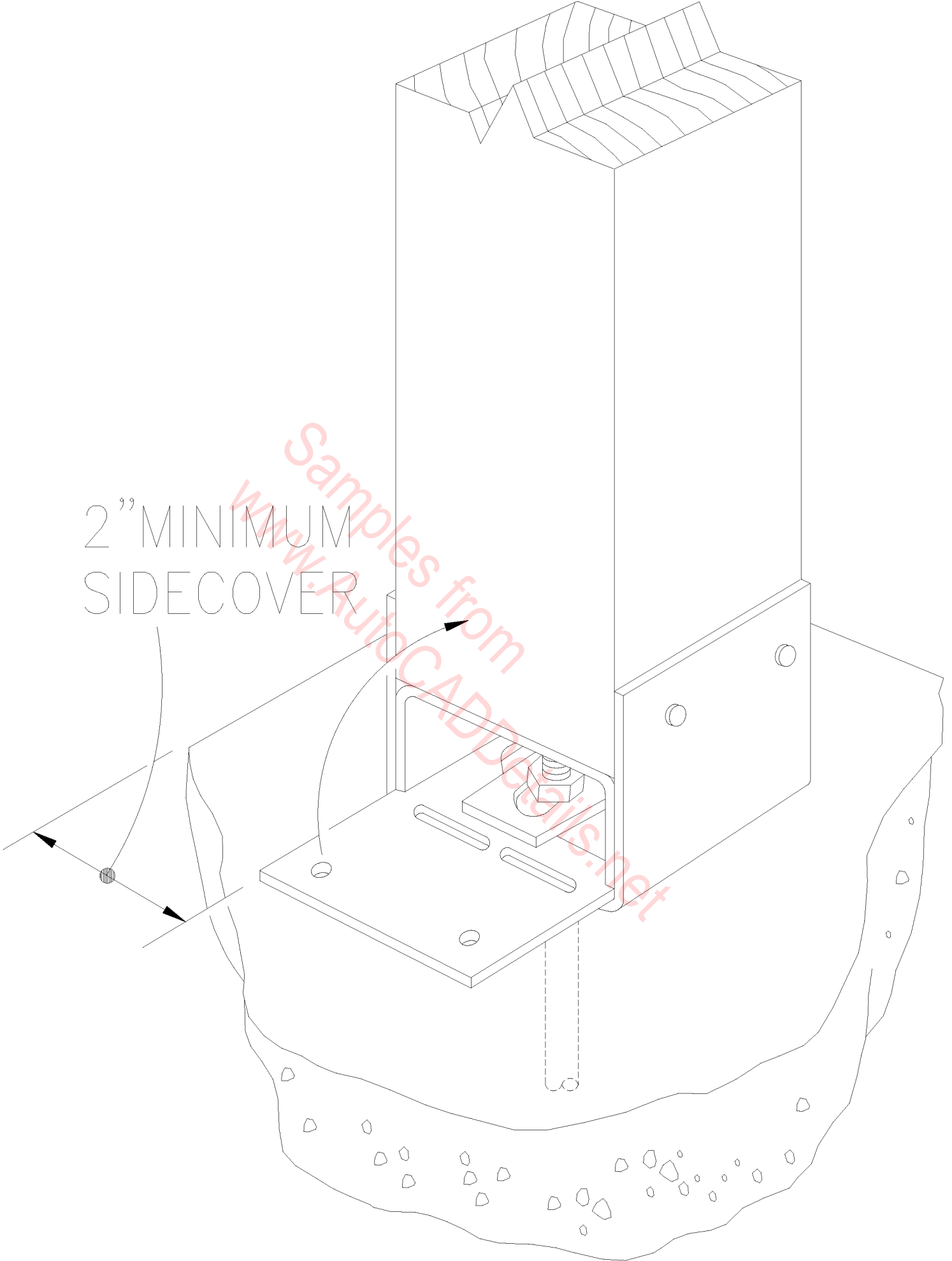

2" MINIMUM  
SIDECOVER

Simpson Strong-Tie  
AB

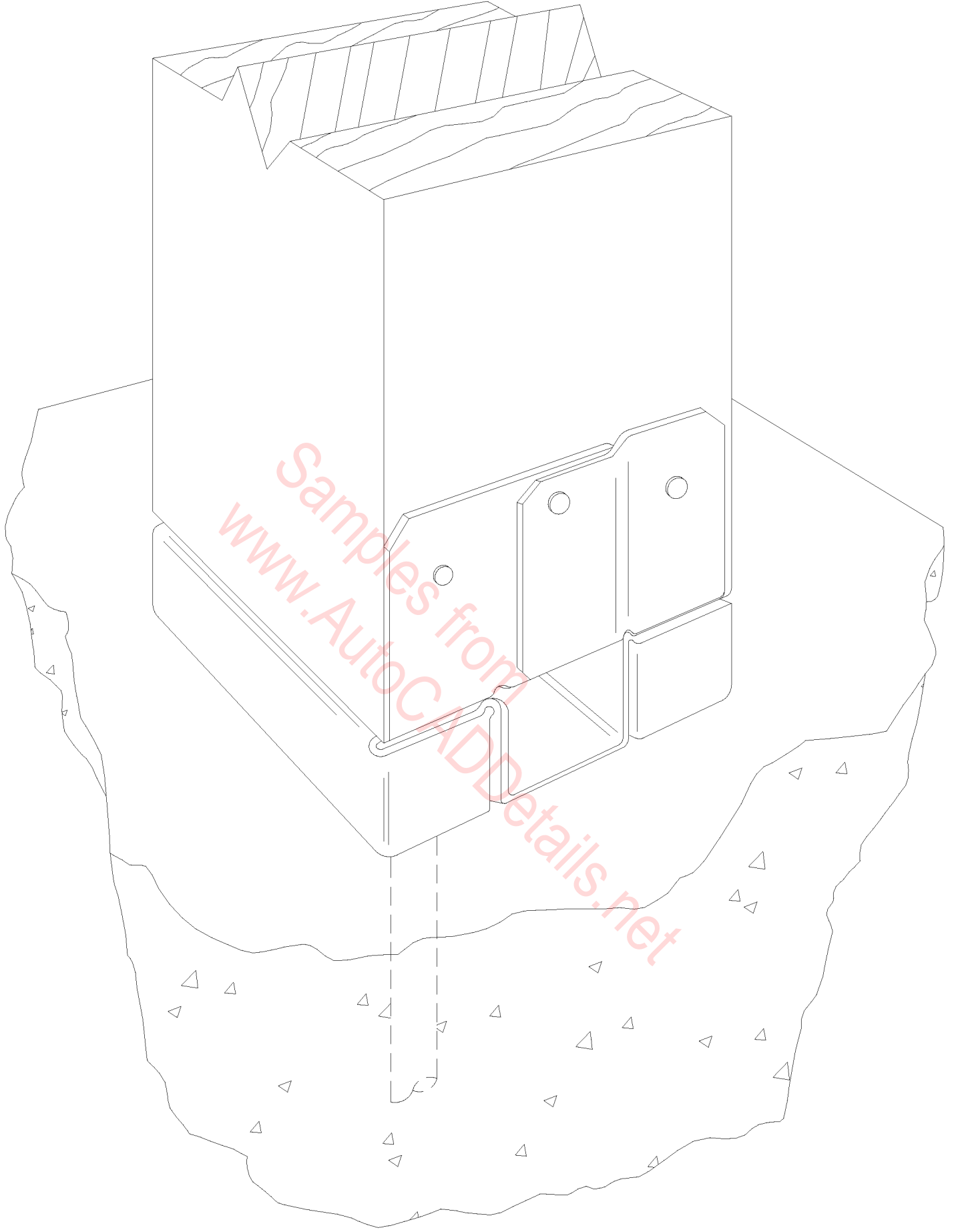

Simpson Strong-Tie  
ABA44

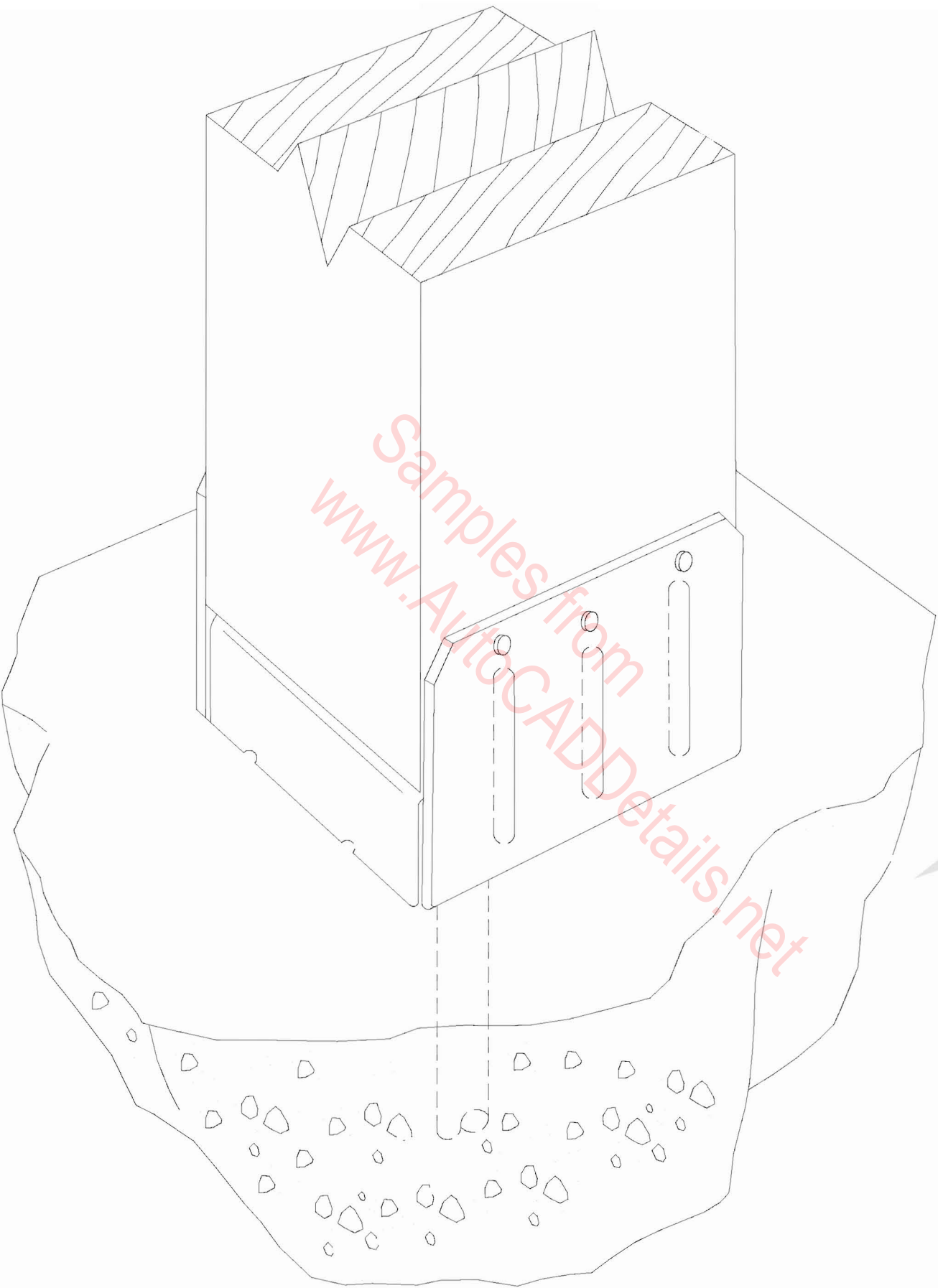

Simpson Strong-Tie  
ABE44

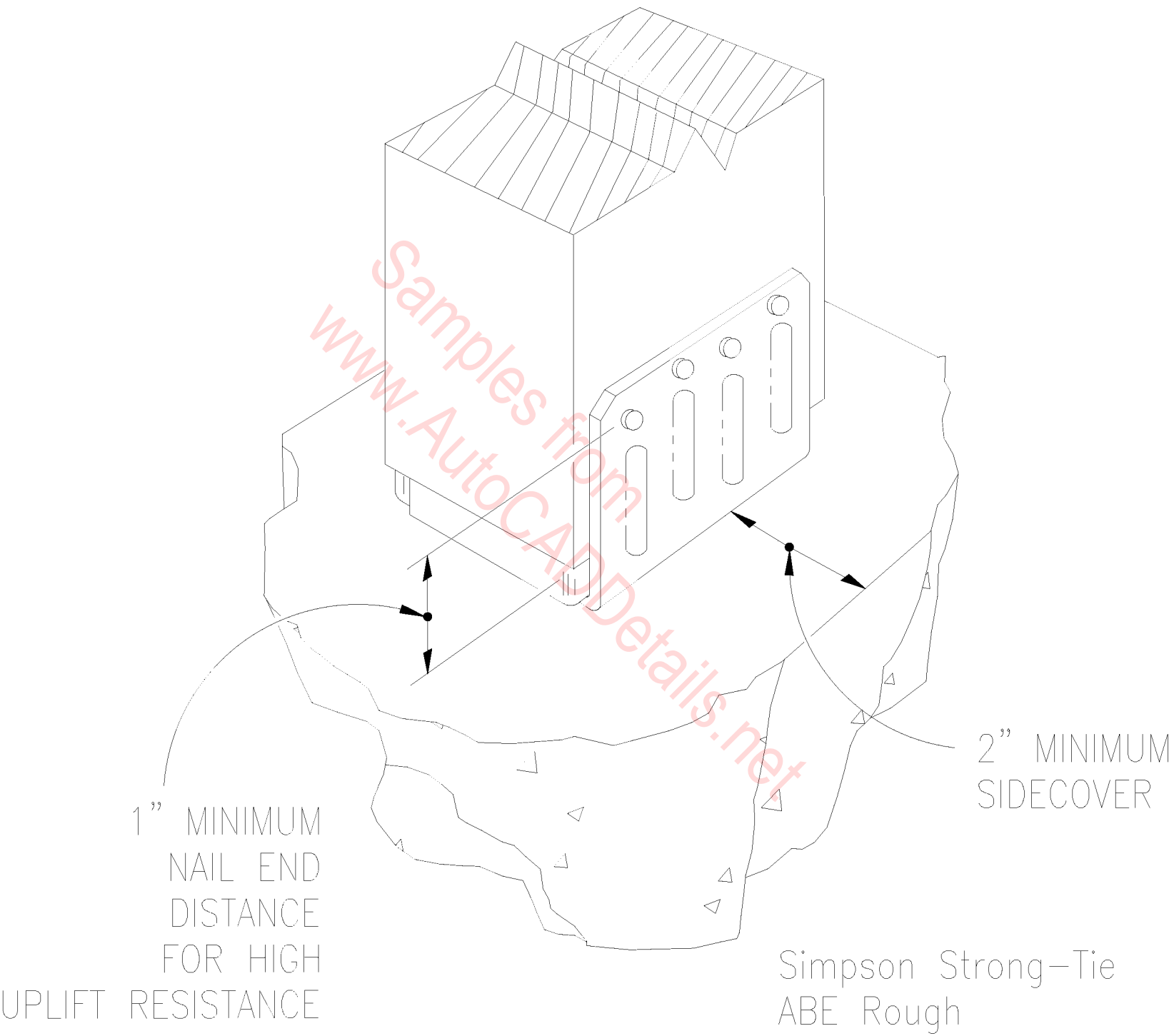



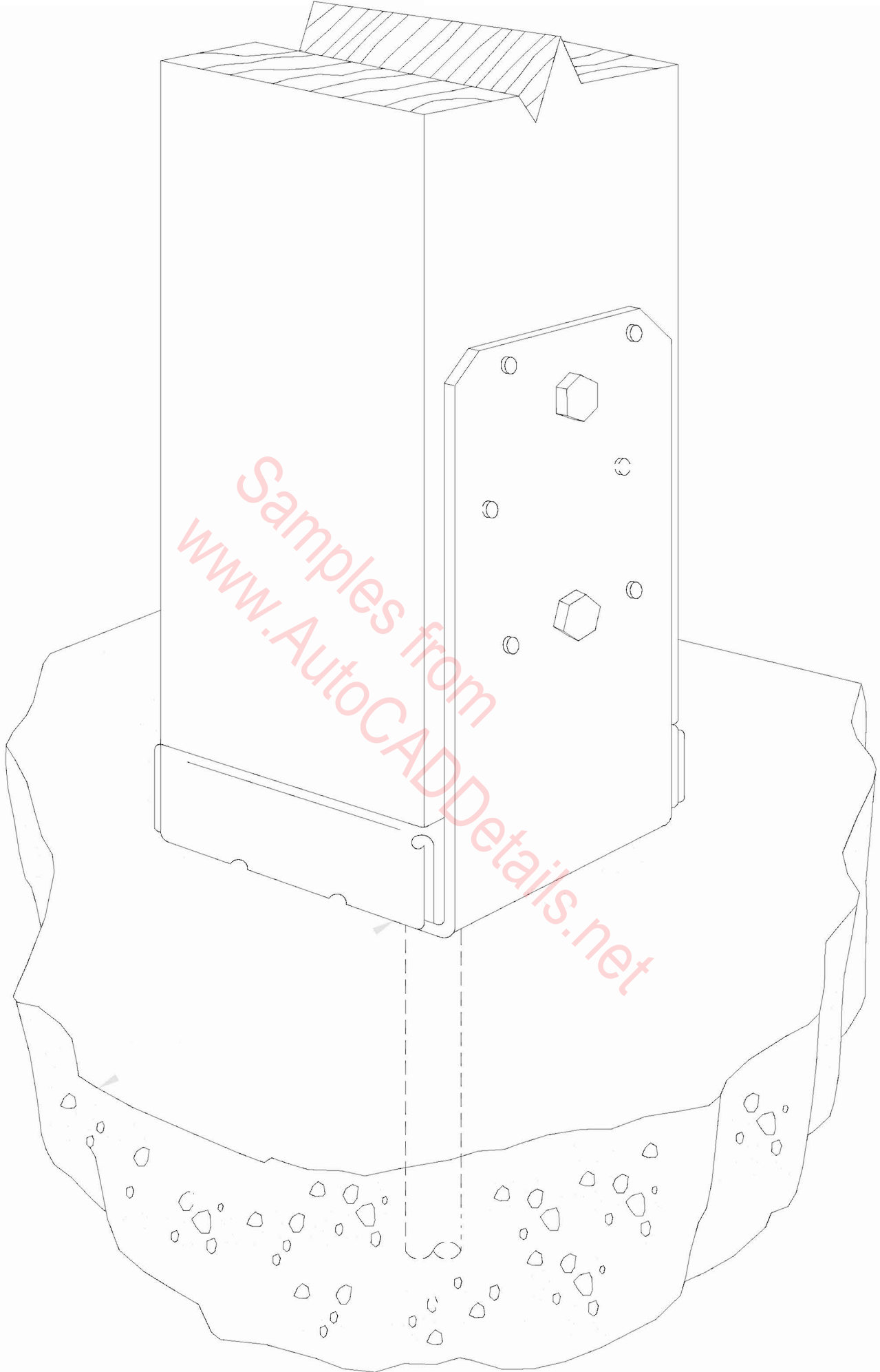

Simpson Strong-Tie  
ABU44

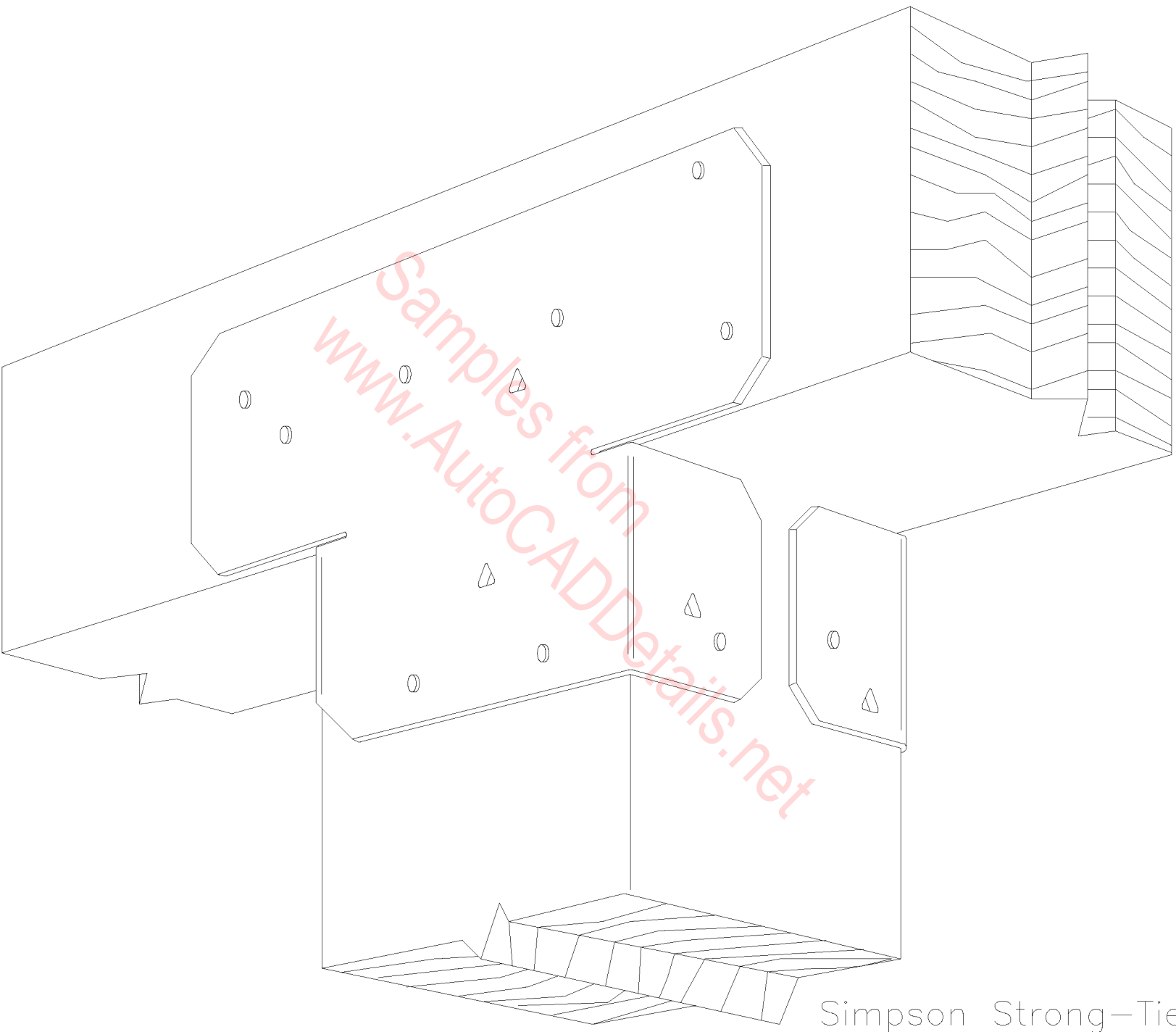

Samples from  
www.AutoCADDetails.net

Simpson Strong-Tie  
AC4

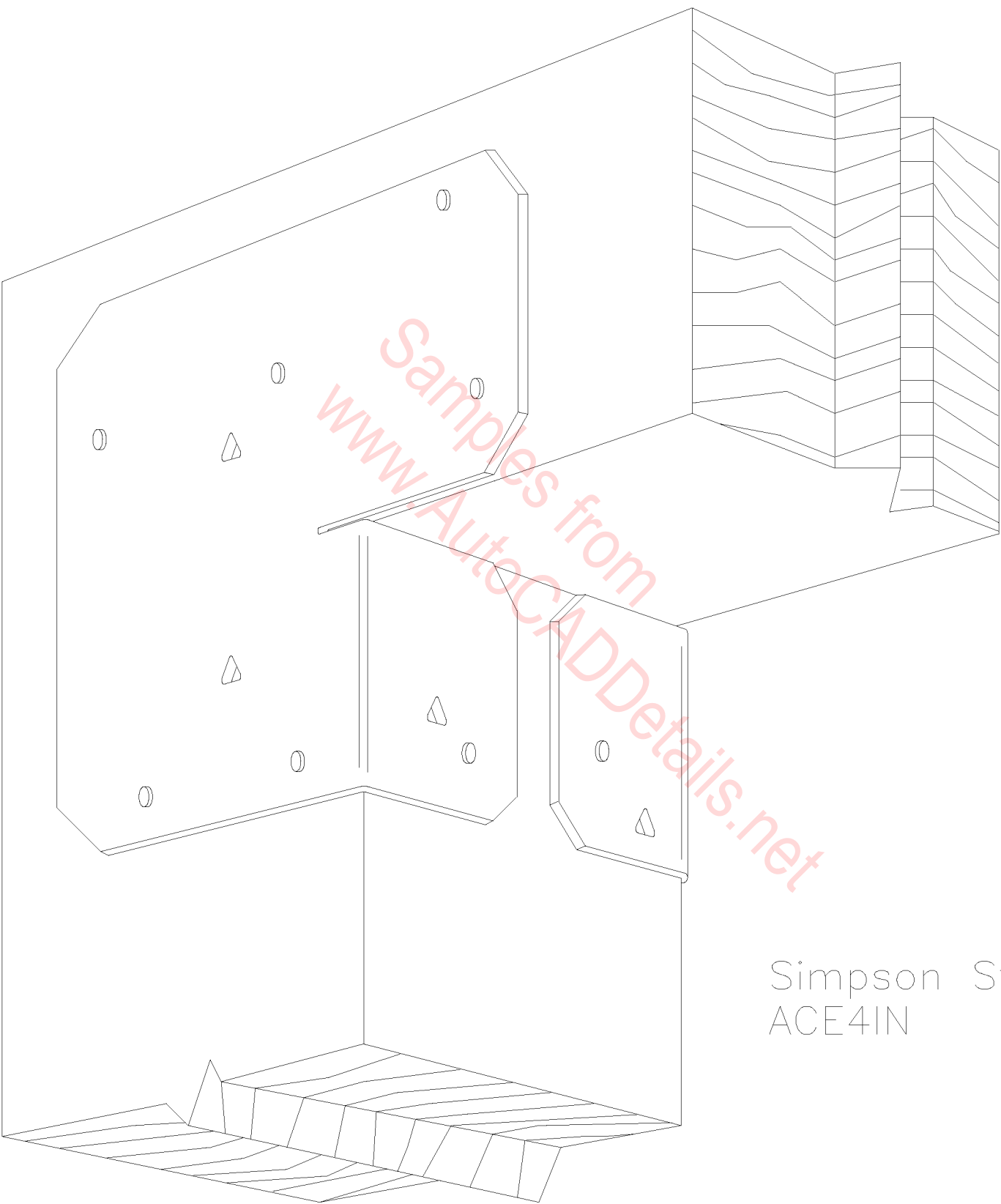

Samples from  
[www.AutoCADDetails.net](http://www.AutoCADDetails.net)

Simpson Strong-Tie  
ACE4IN

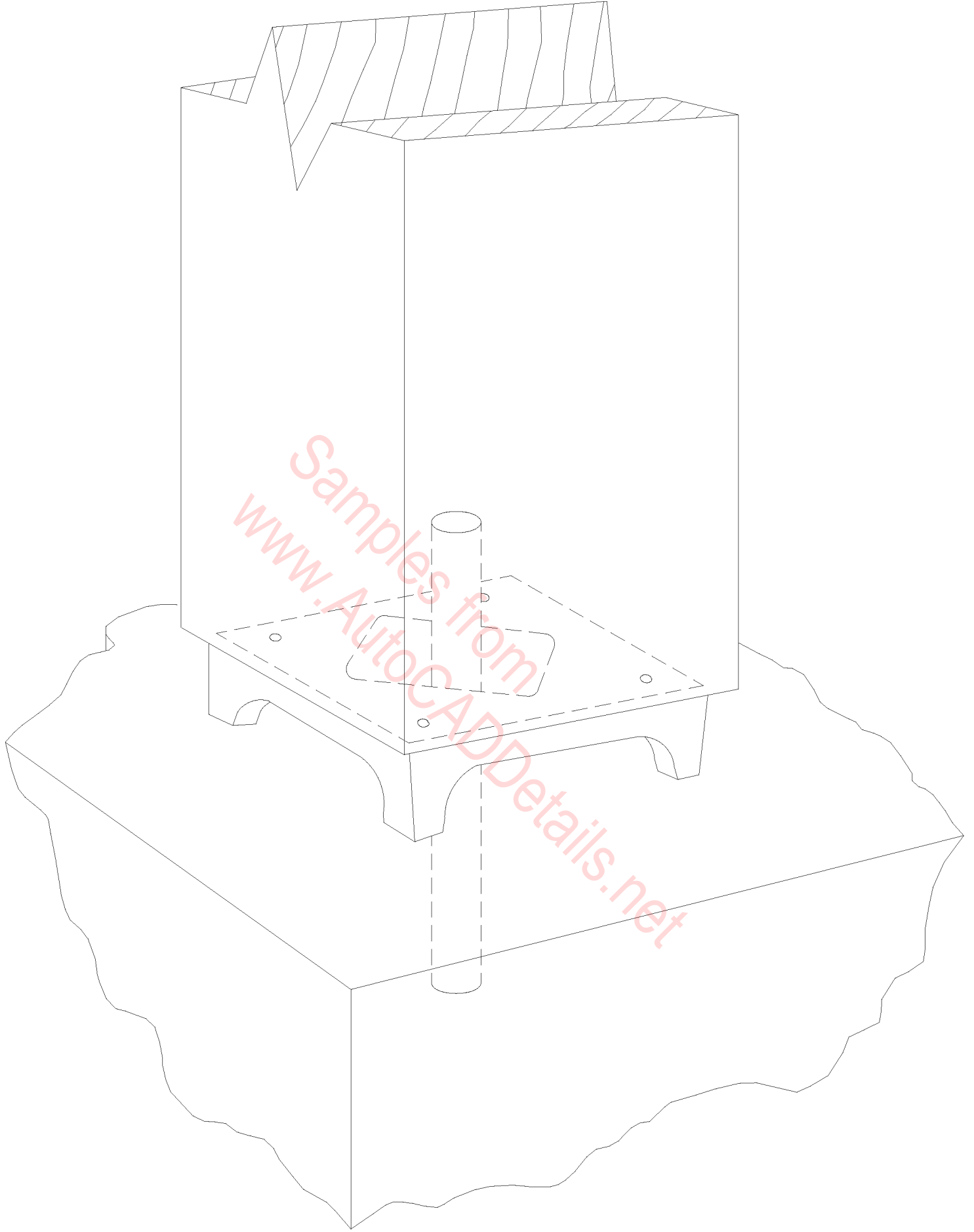

Simpson Strong-Tie  
APS4

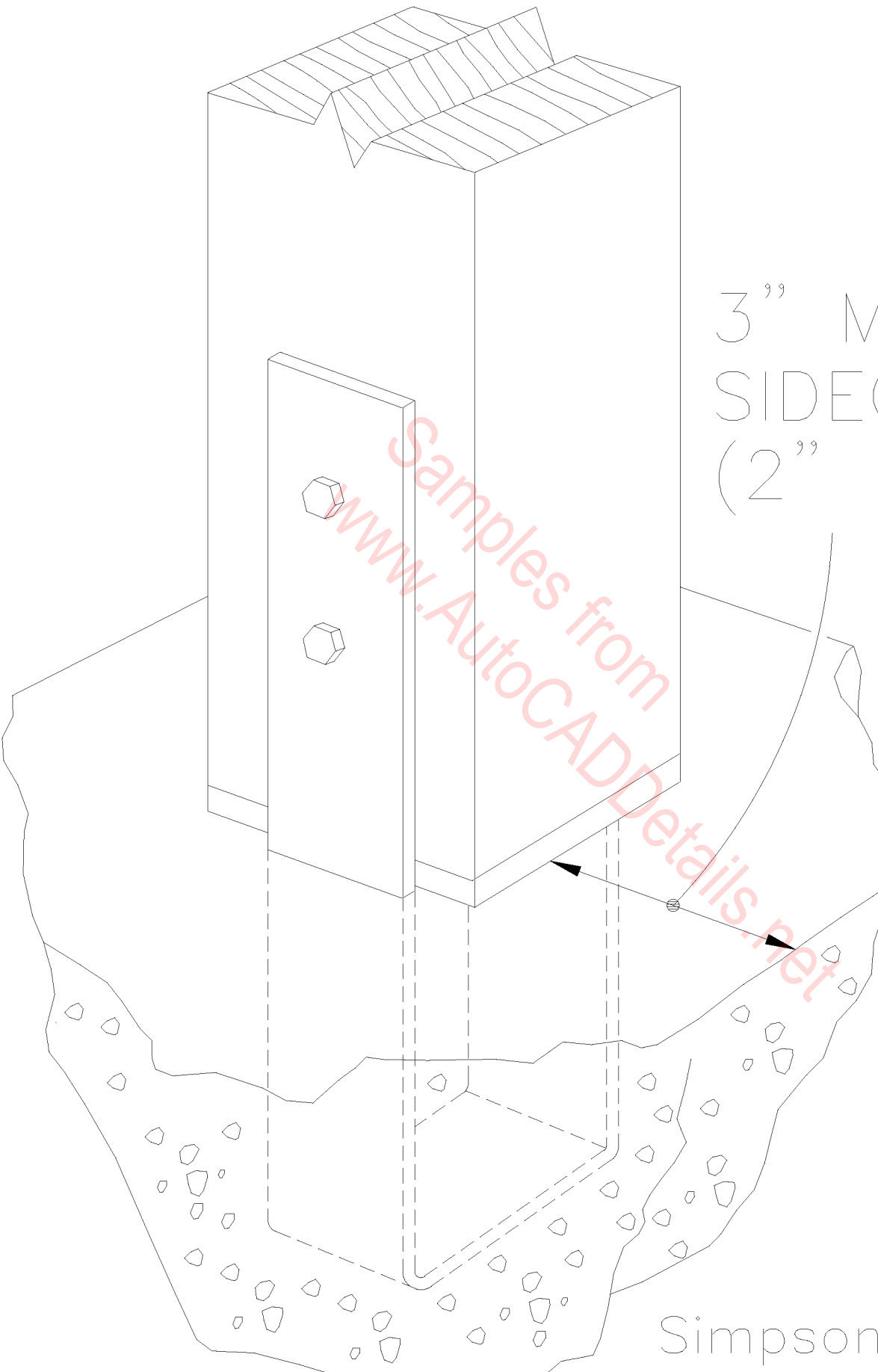

3" MINIMUM  
SIDECOVER  
(2" FOR LCB)

Simpson Strong-Tie  
CB or LCB

3" MINIMUM  
SIDECOVER

1" STANDOFF  
SATISFIES  
CODE  
REQUIREMENTS

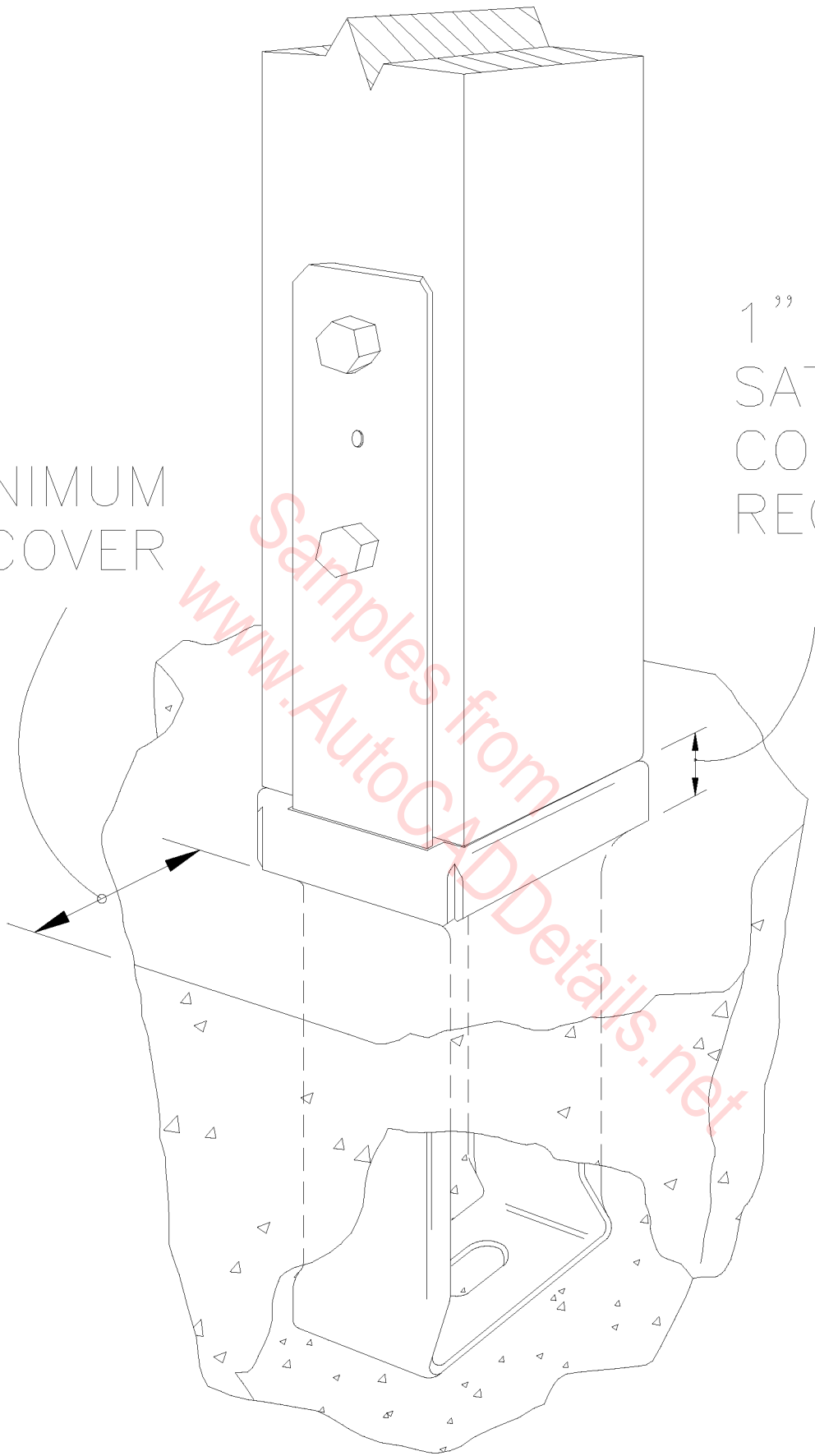

Simpson Strong-Tie  
CBS44

Samples from  
[www.AutoCADDetails.net](http://www.AutoCADDetails.net)

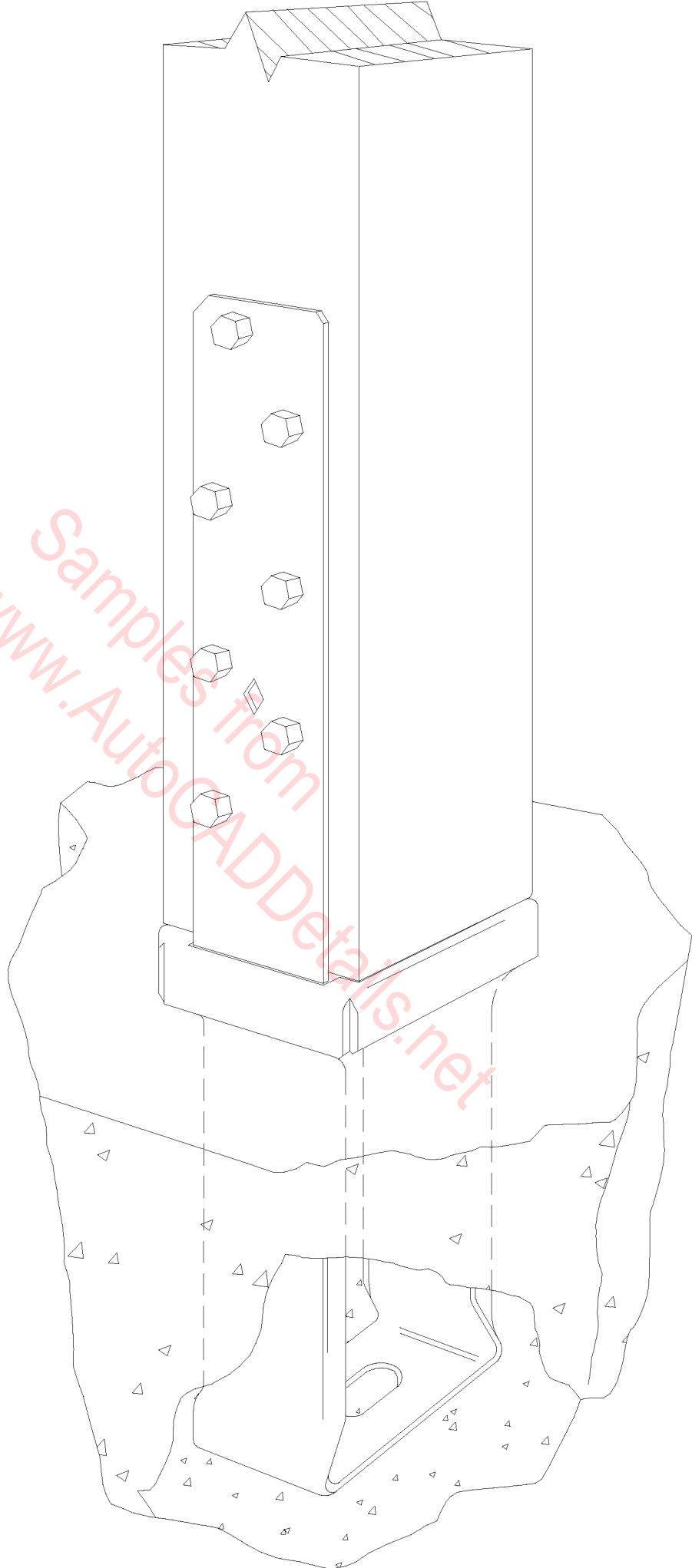

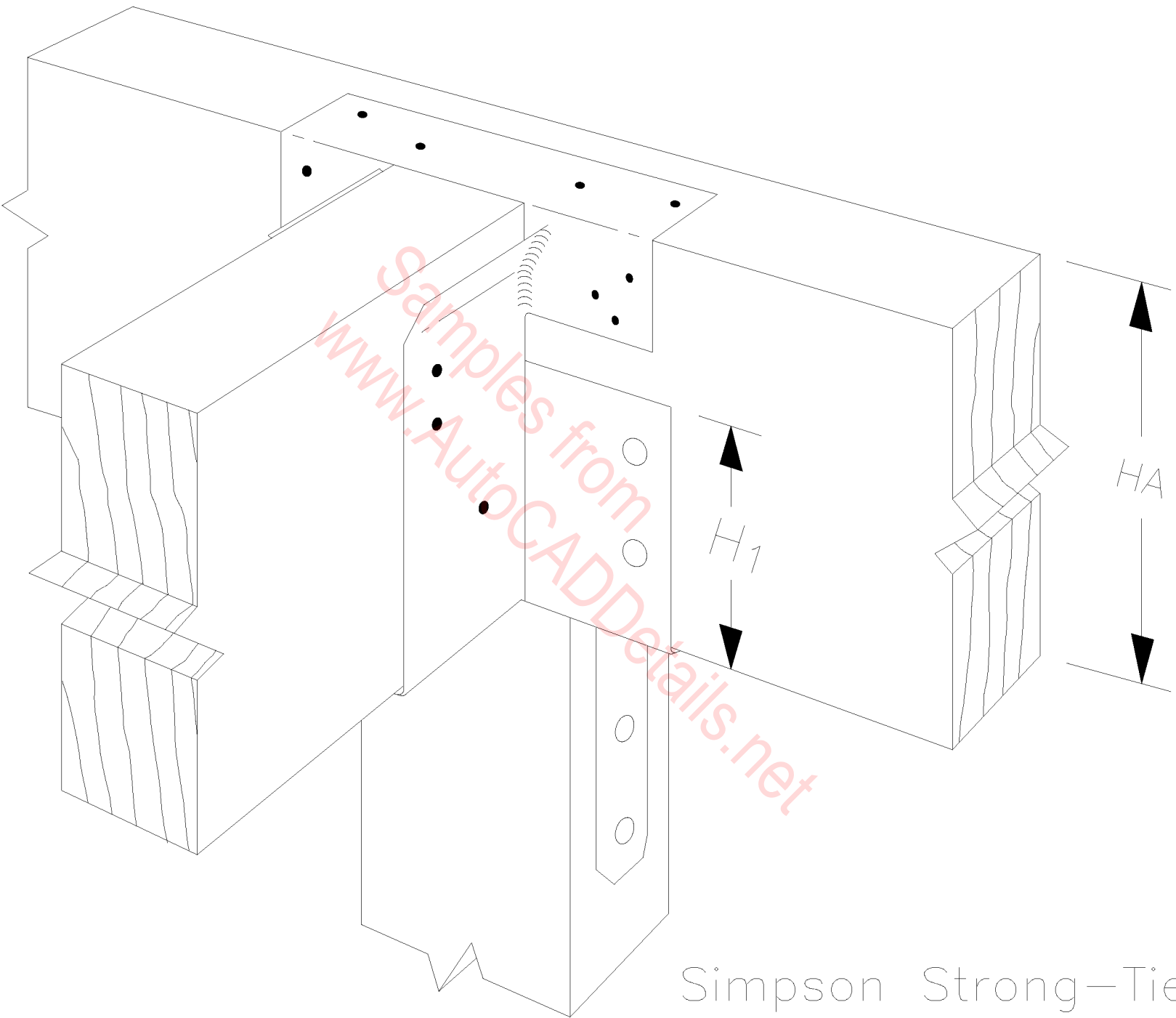

Simpson Strong-Tie  
CC with GLT



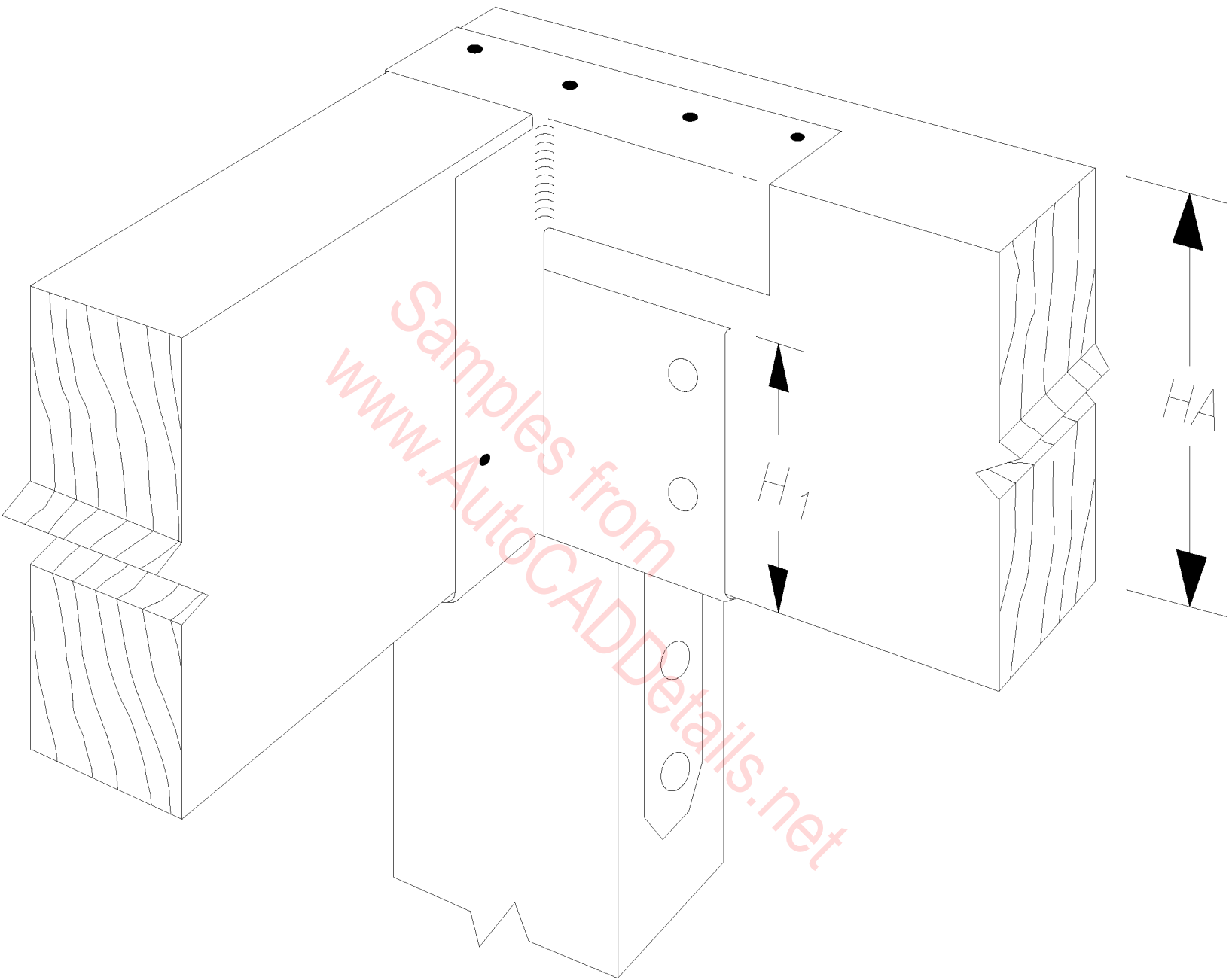

Simpson Strong-Tie  
CC with HW

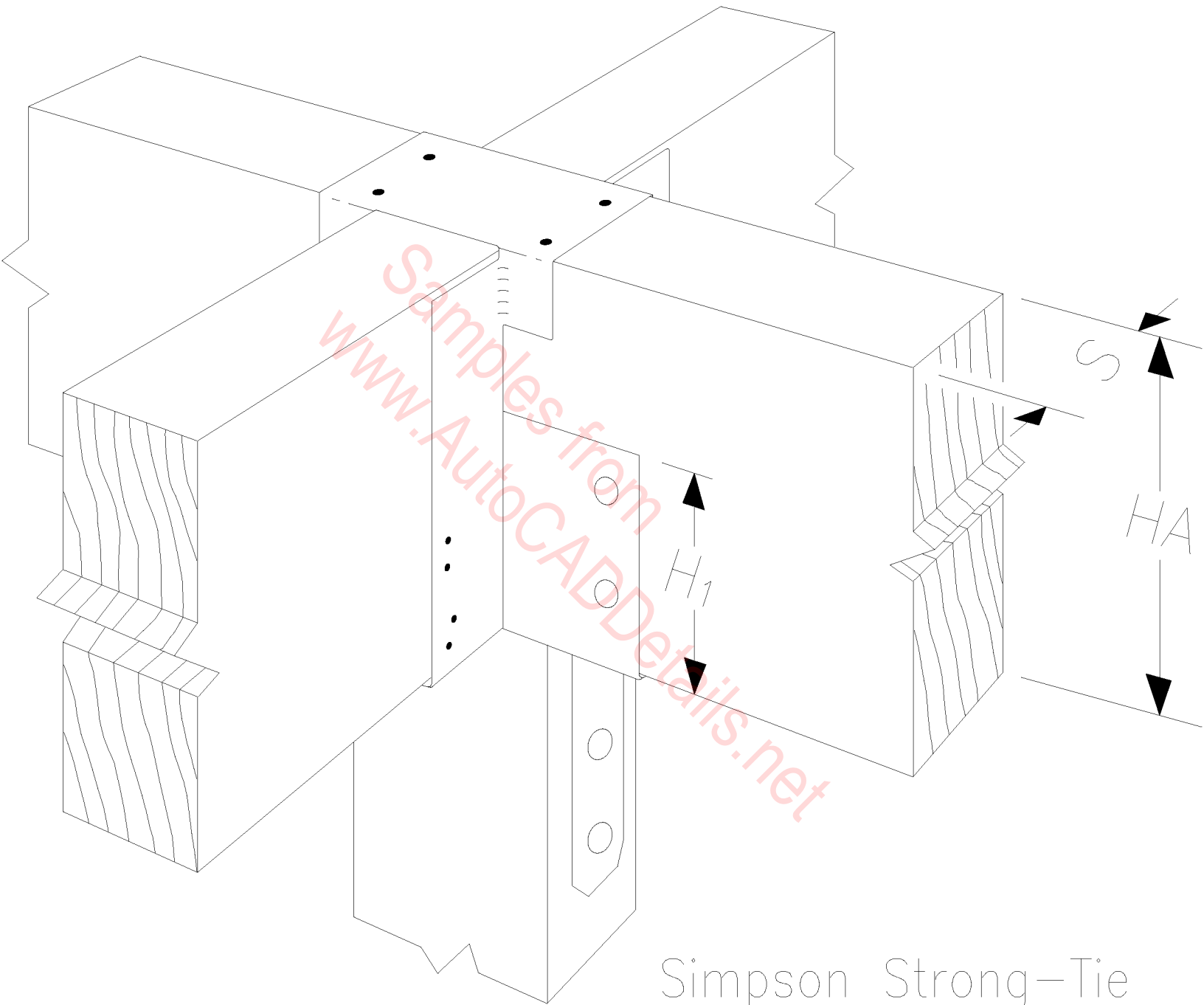

Simpson Strong-Tie  
CC with WD

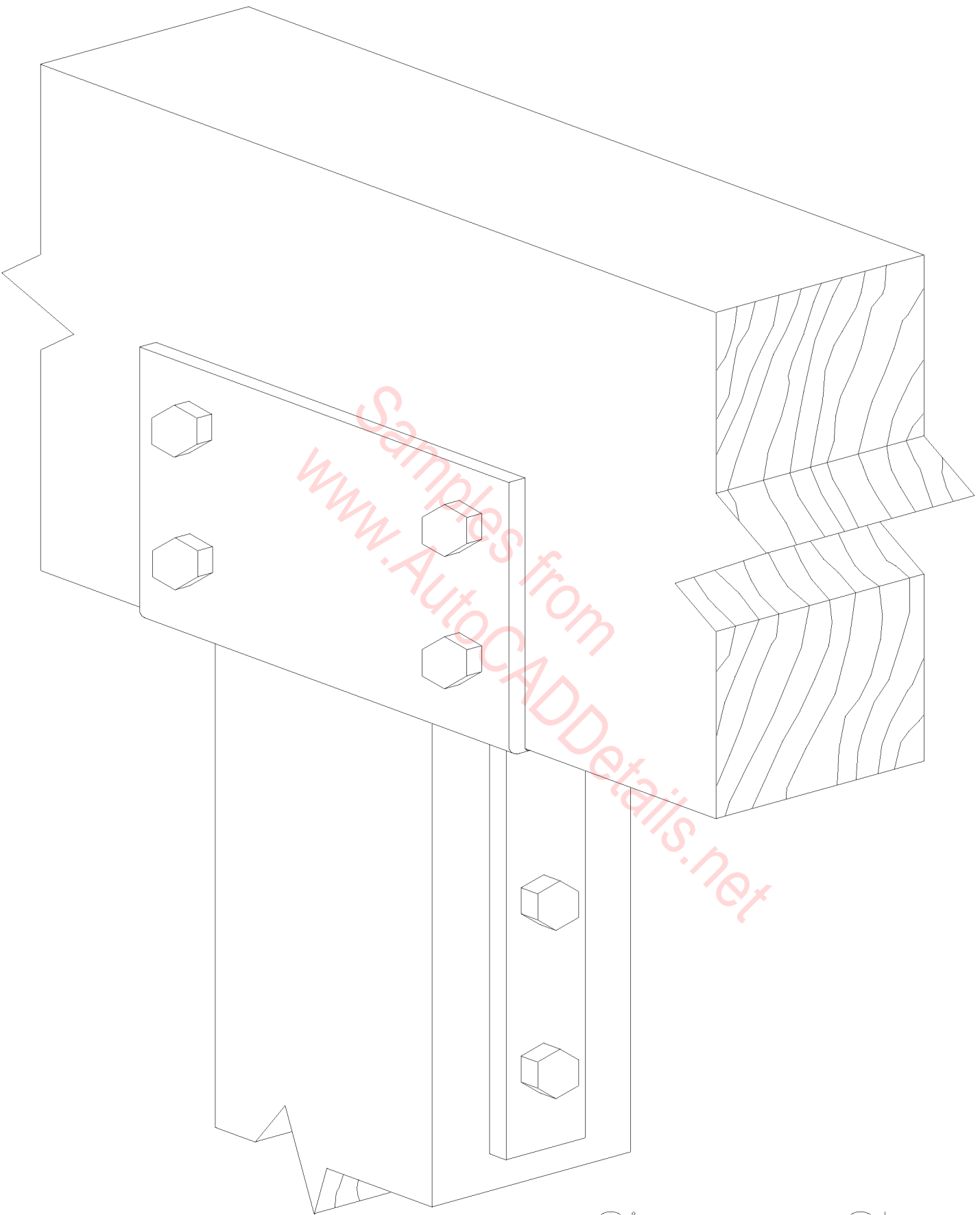

Simpson Strong-Tie  
CC66

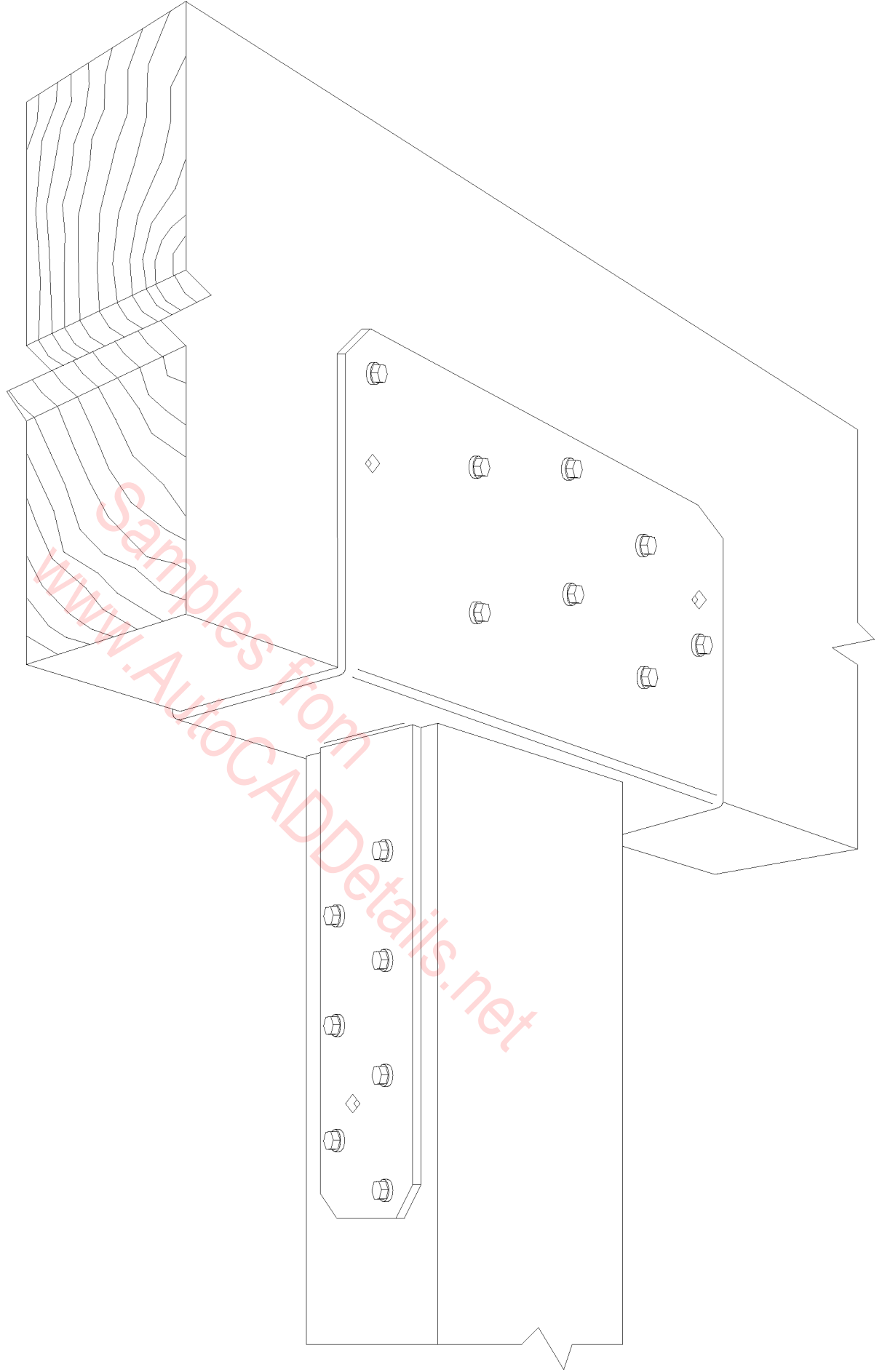

Simpson Strong-Tie  
CCQ46

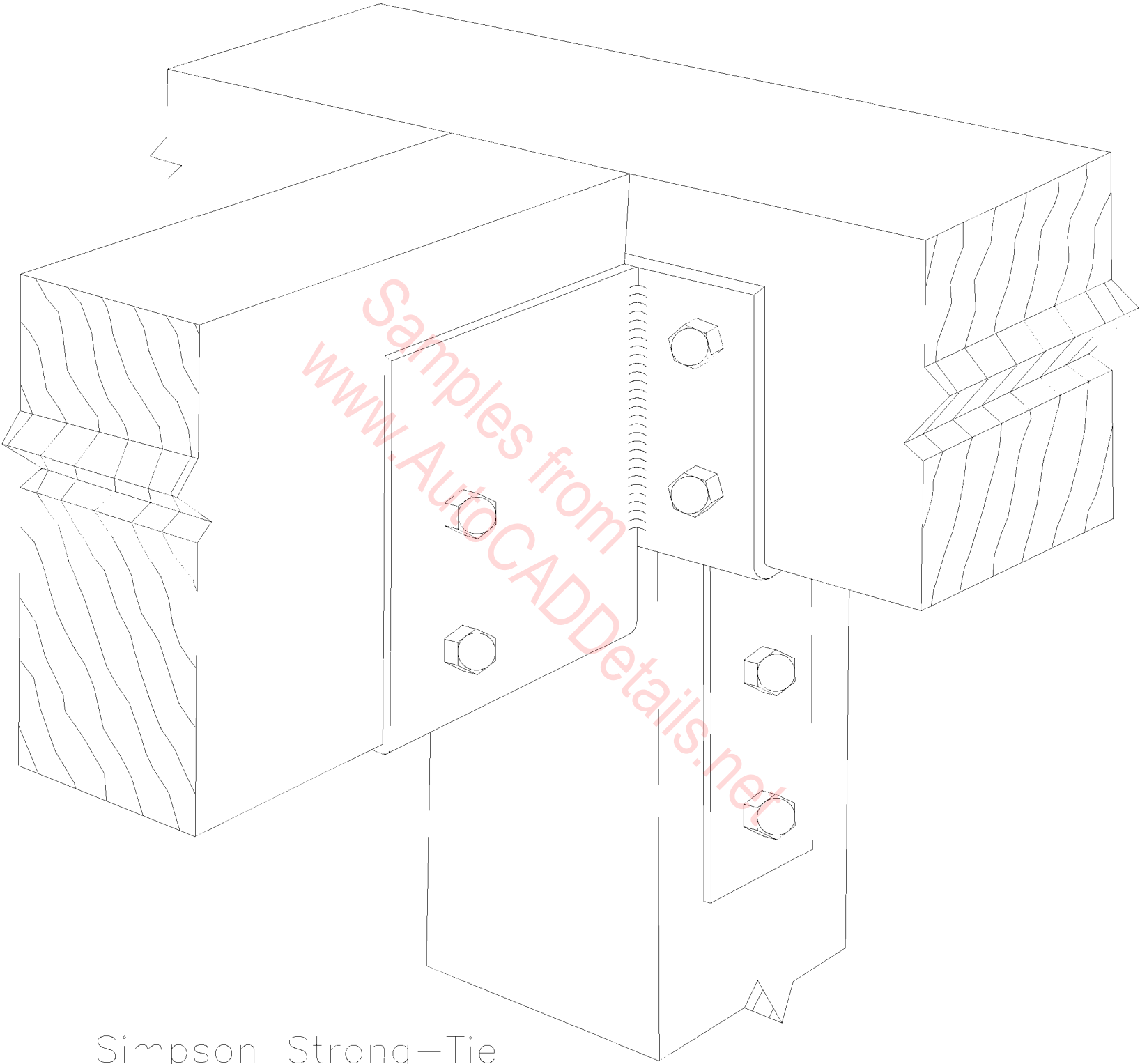

Simpson Strong-Tie  
CCT

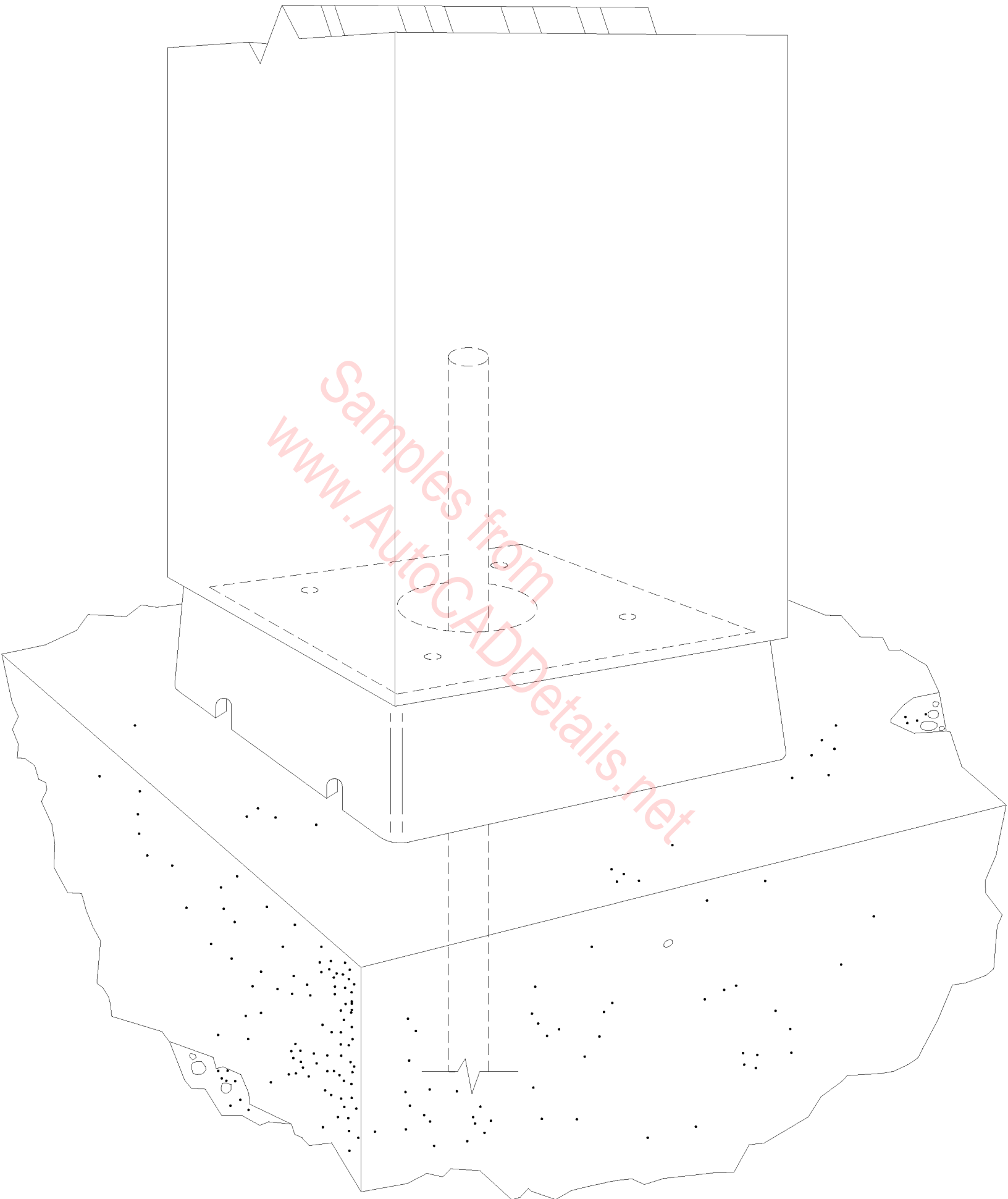

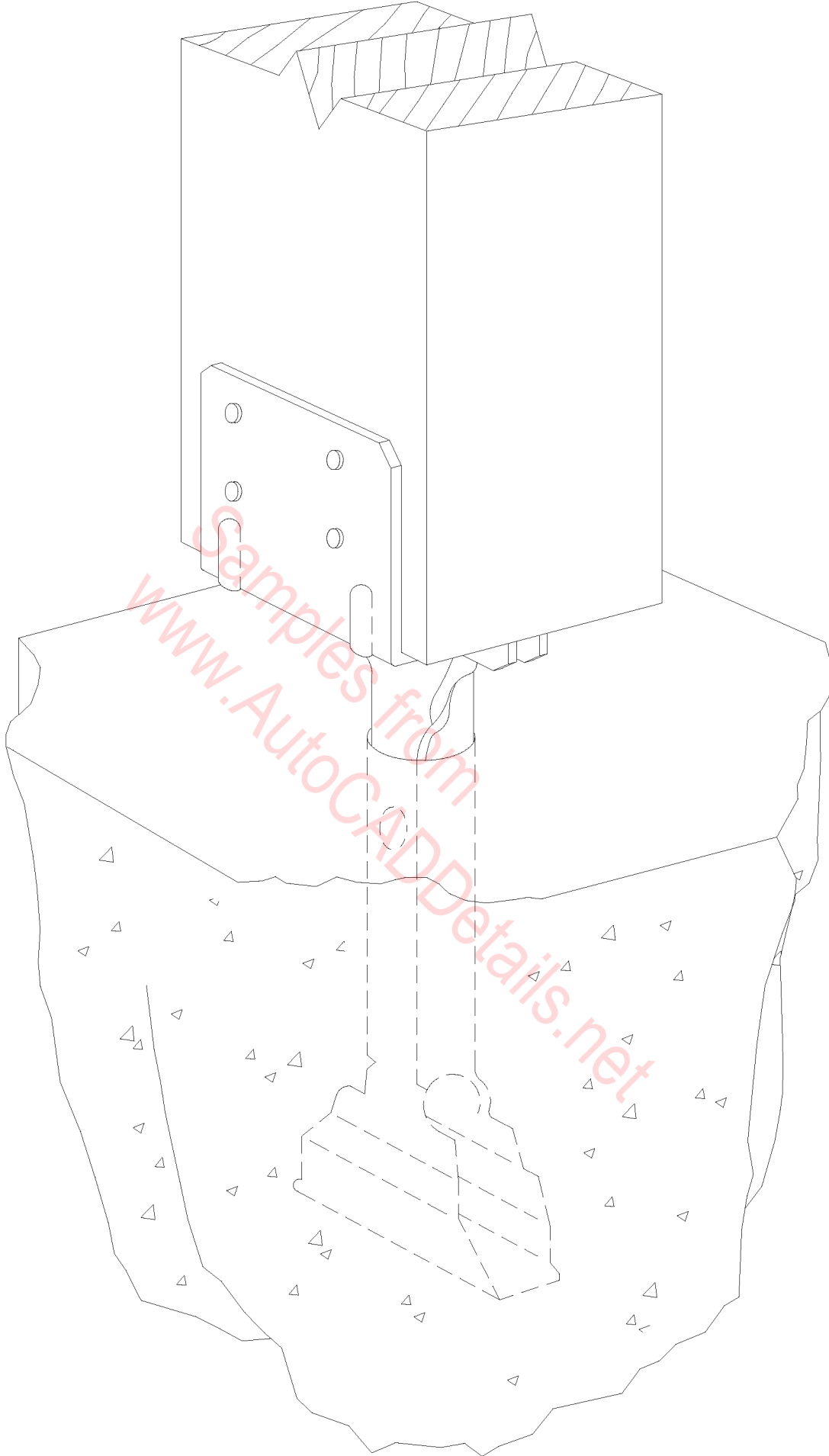

Simpson Strong-Tie  
EPB44A

NUT AND  
WASHER FOR  
ADJUSTABILITY  
NO UPLIFT

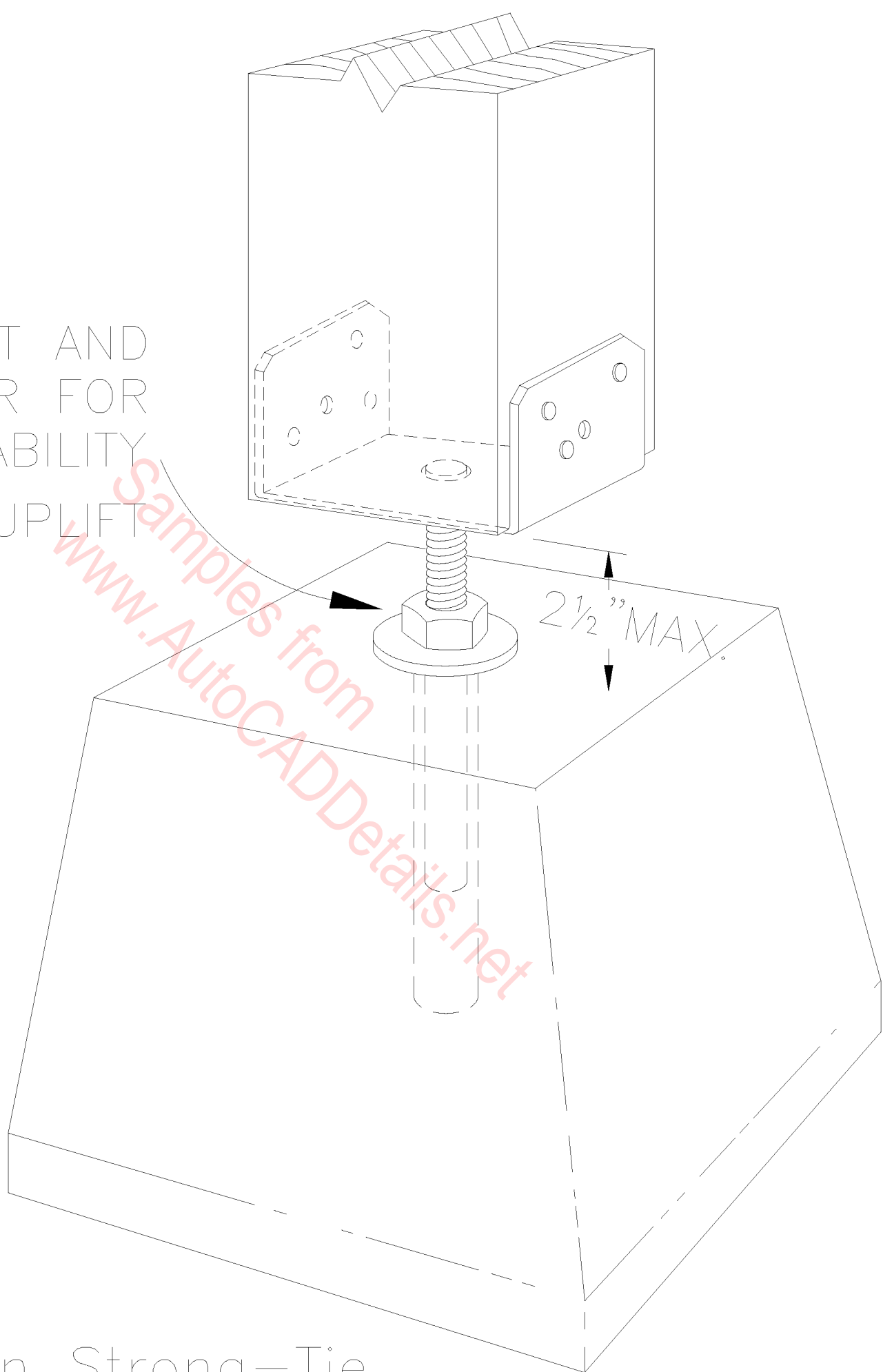

Simpson Strong-Tie  
EPB44T



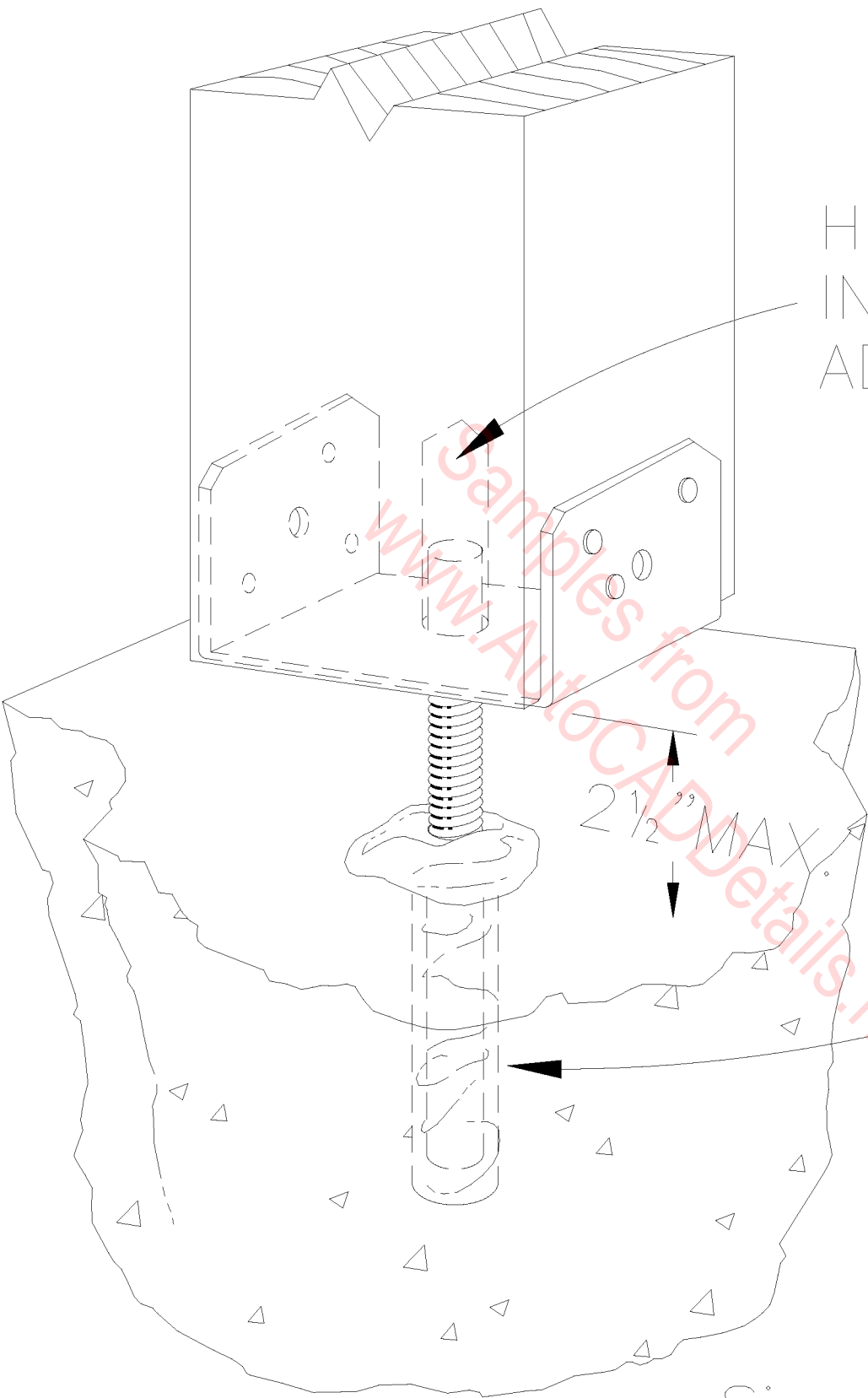

HOLE DRILLED  
INTO POST FOR  
ADJUSTABILITY

2 1/2" MAX.

EPOXY OR  
CAST IN  
PLACE FOR  
UPLIFT

Simpson Strong-Tie  
EPB44T

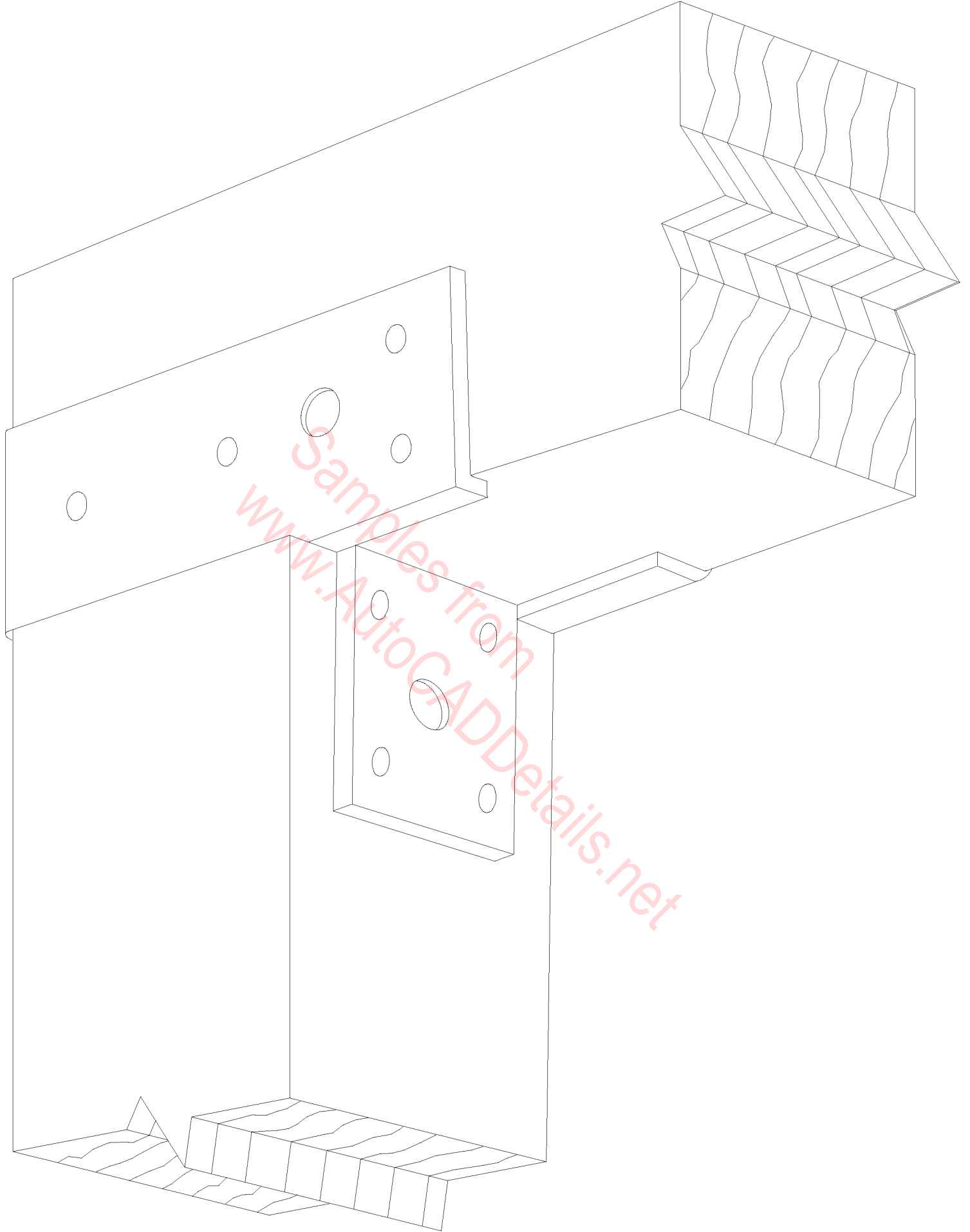

Simpson Strong-Tie  
EPC

OPTIONAL  
DRILL  
THROUGH

7/8" D x 4"  
HOLE

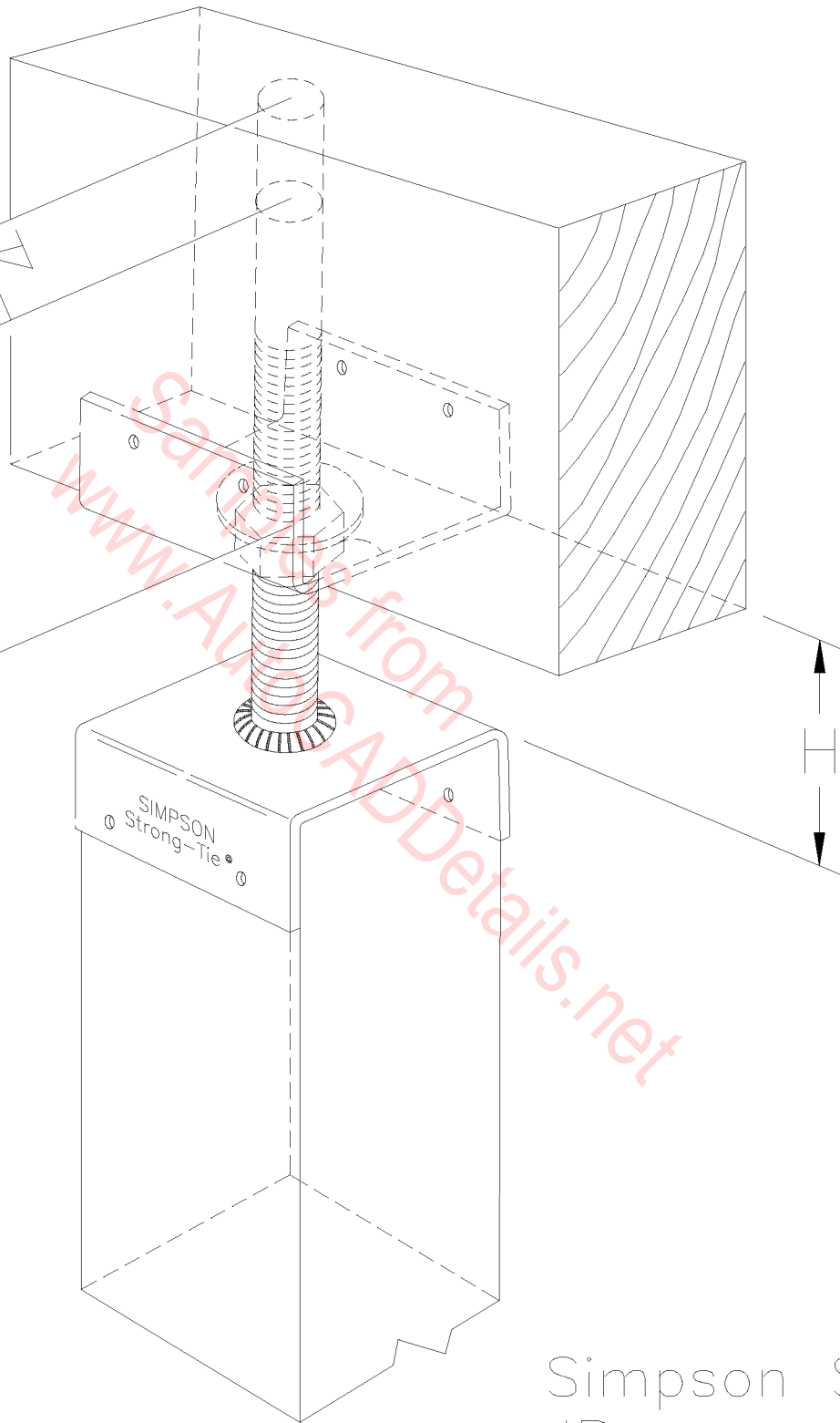

Simpson Strong-Tie  
JP

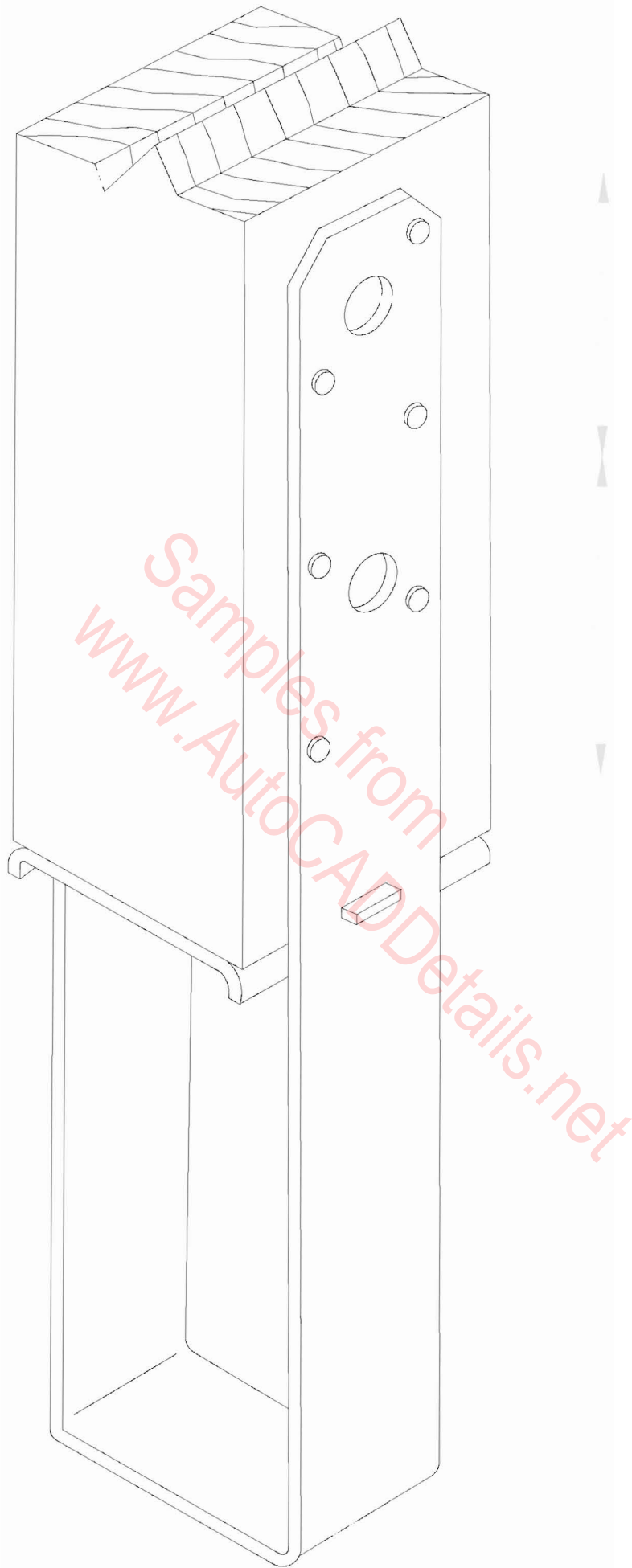

Simpson Strong-Tie  
LCB

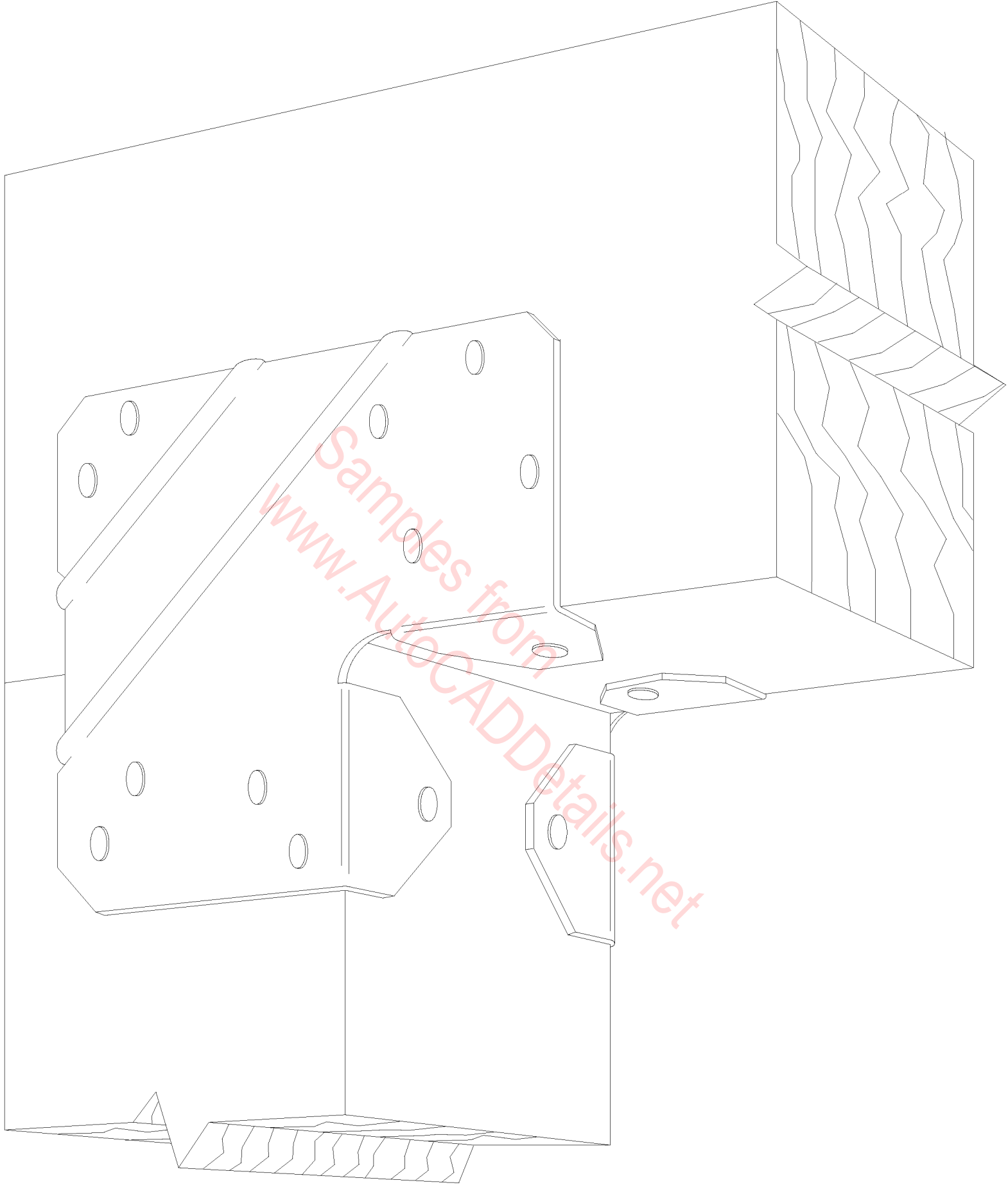

Simpson Strong-Tie  
LCE4

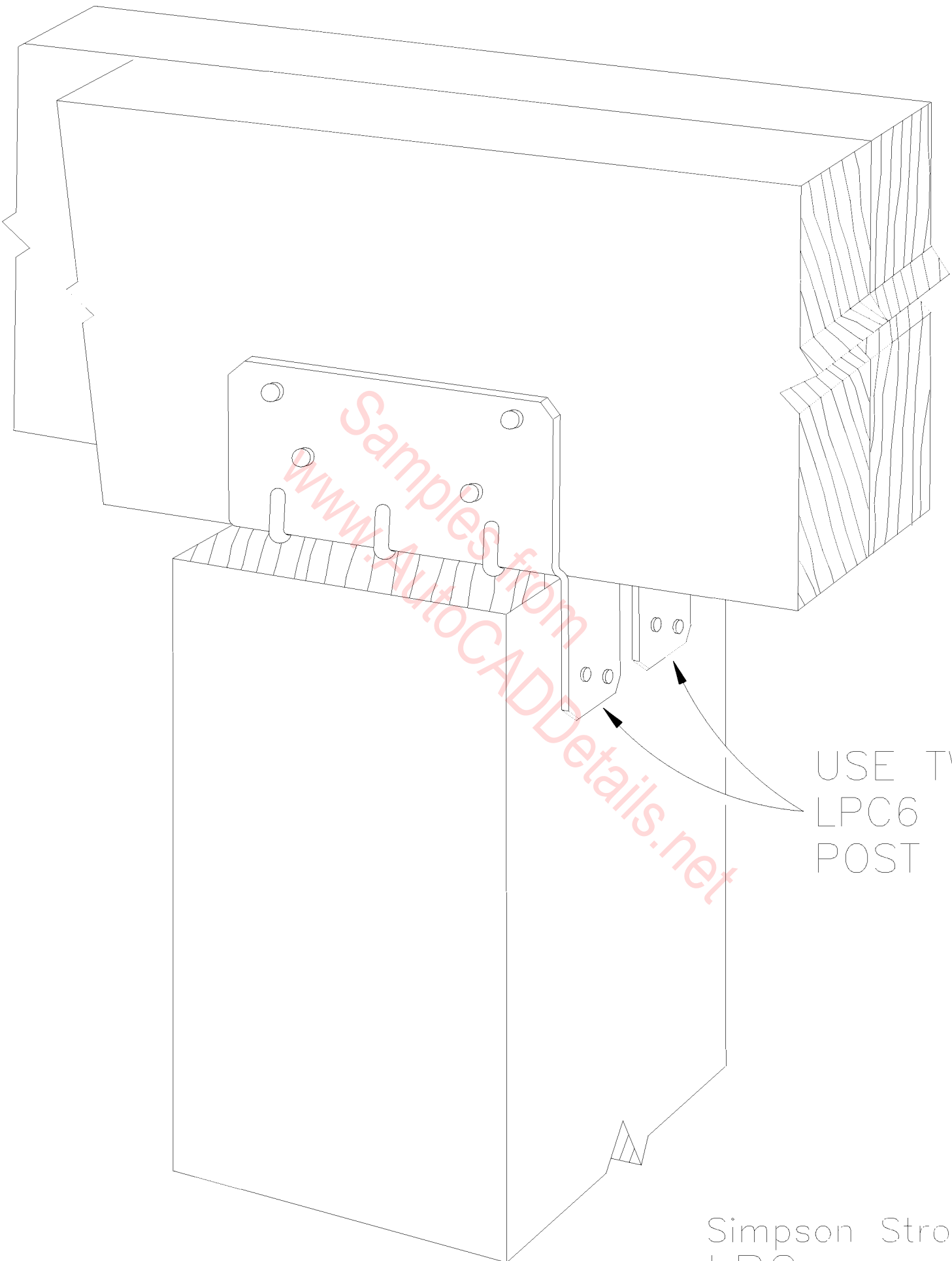

USE TWO  
LPC6  
POST CAPS

Simpson Strong-Tie  
LPC

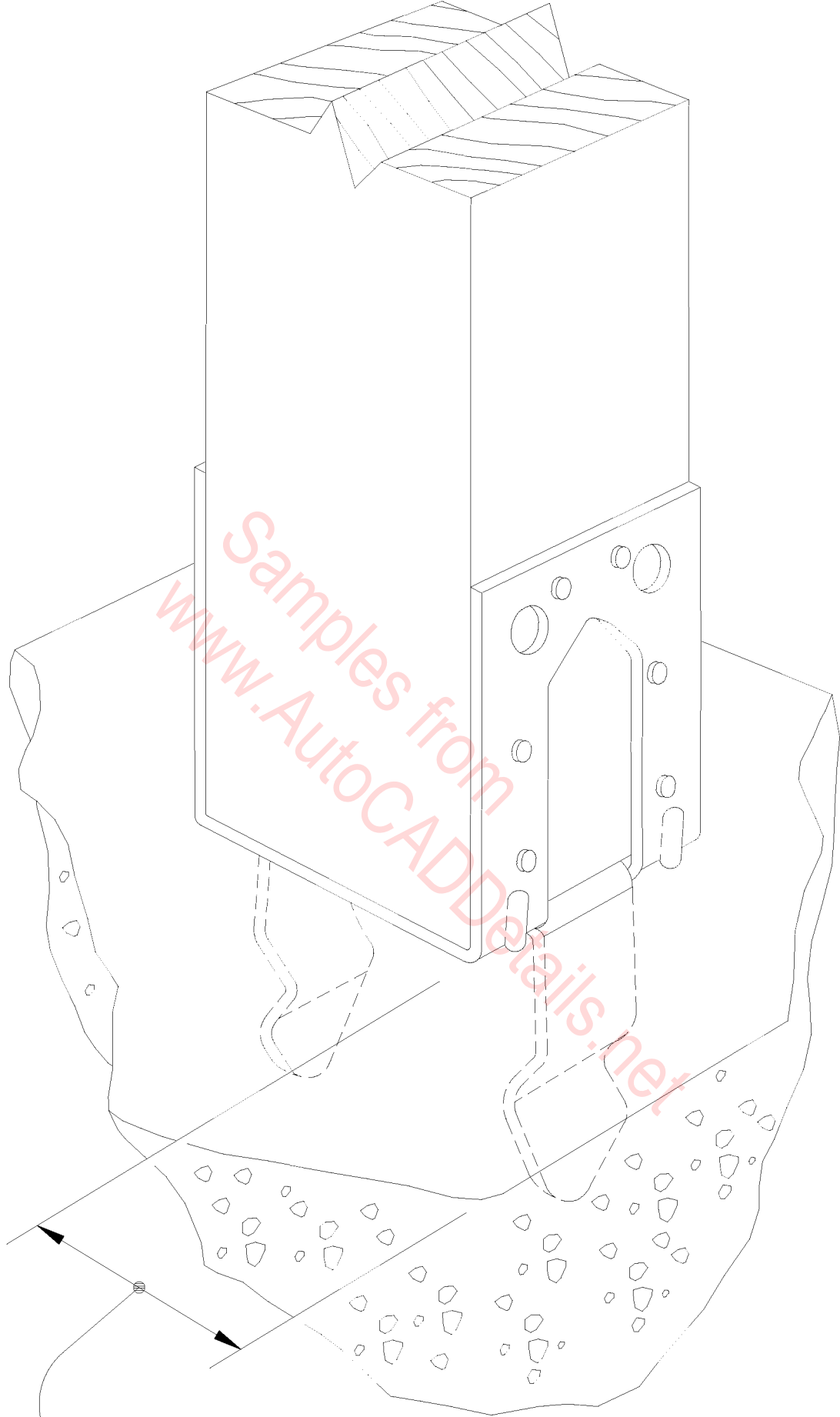

Samples from  
[www.AutoCADDetails.net](http://www.AutoCADDetails.net)

2" MINIMUM SIDECOVER

Simpson Strong-Tie  
PB44

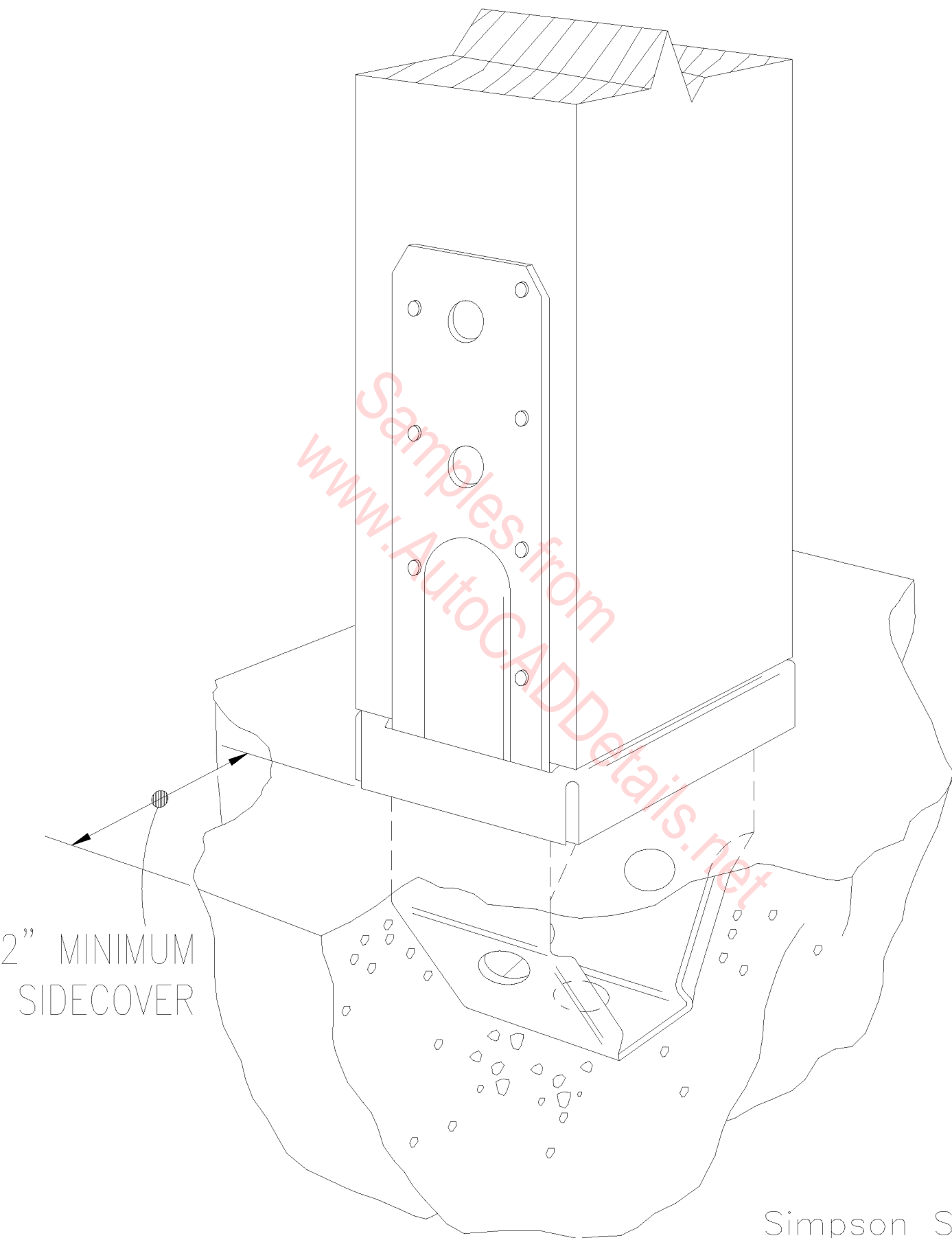

2" MINIMUM  
SIDECOVER

Simpson Strong-Tie  
PBS44



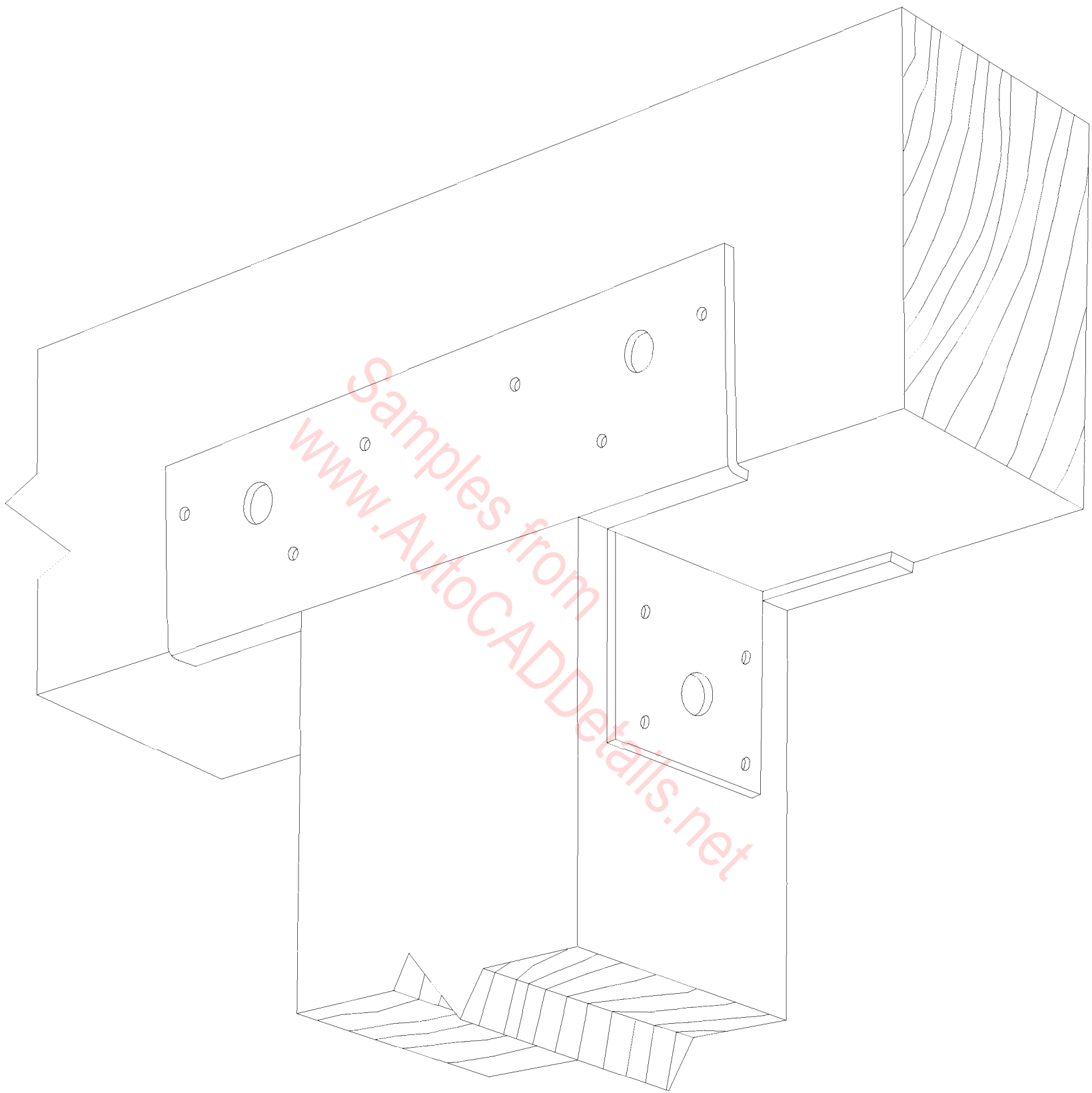

Simpson Strong-Tie  
PC

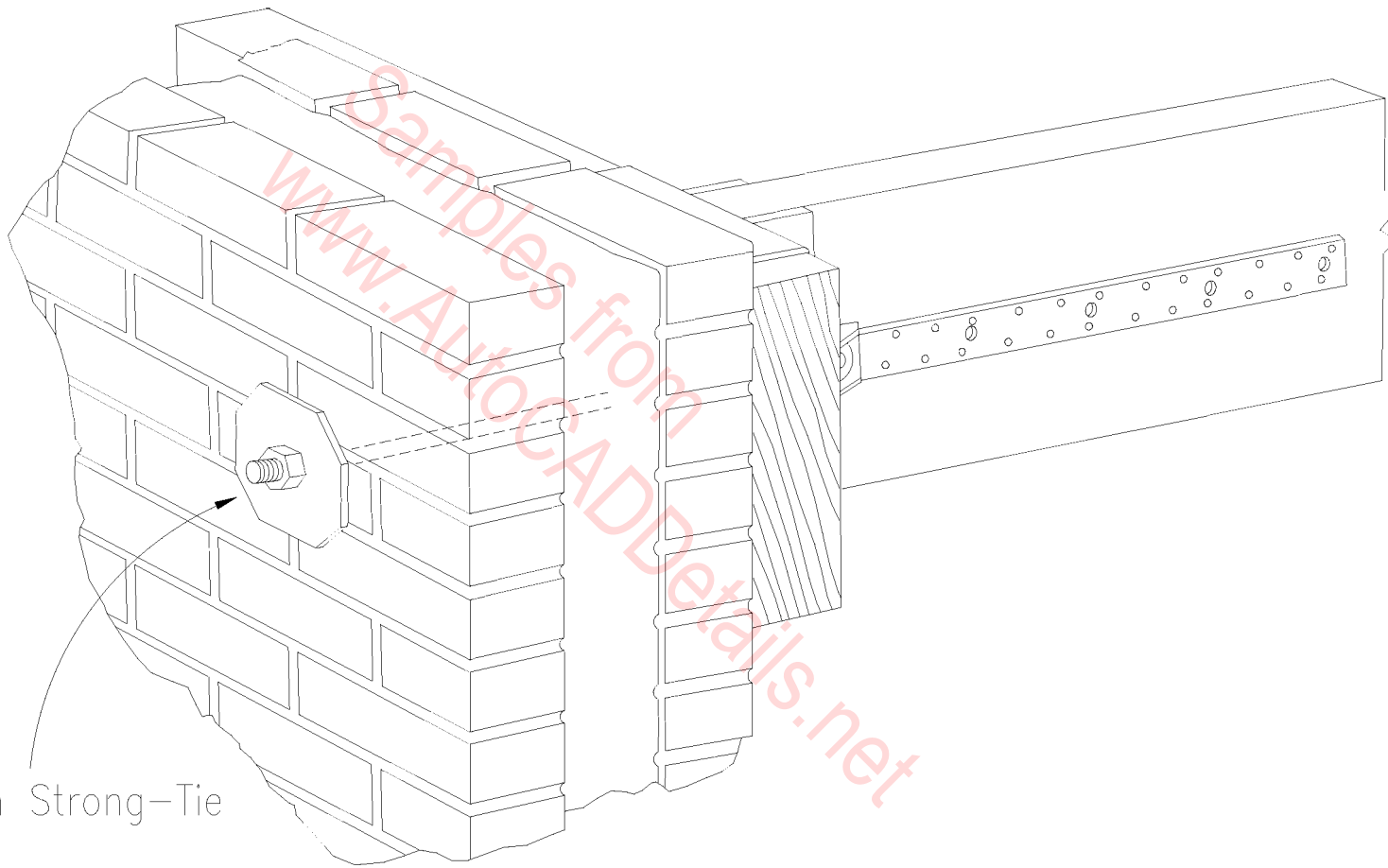

Simpson Strong-Tie  
RP6

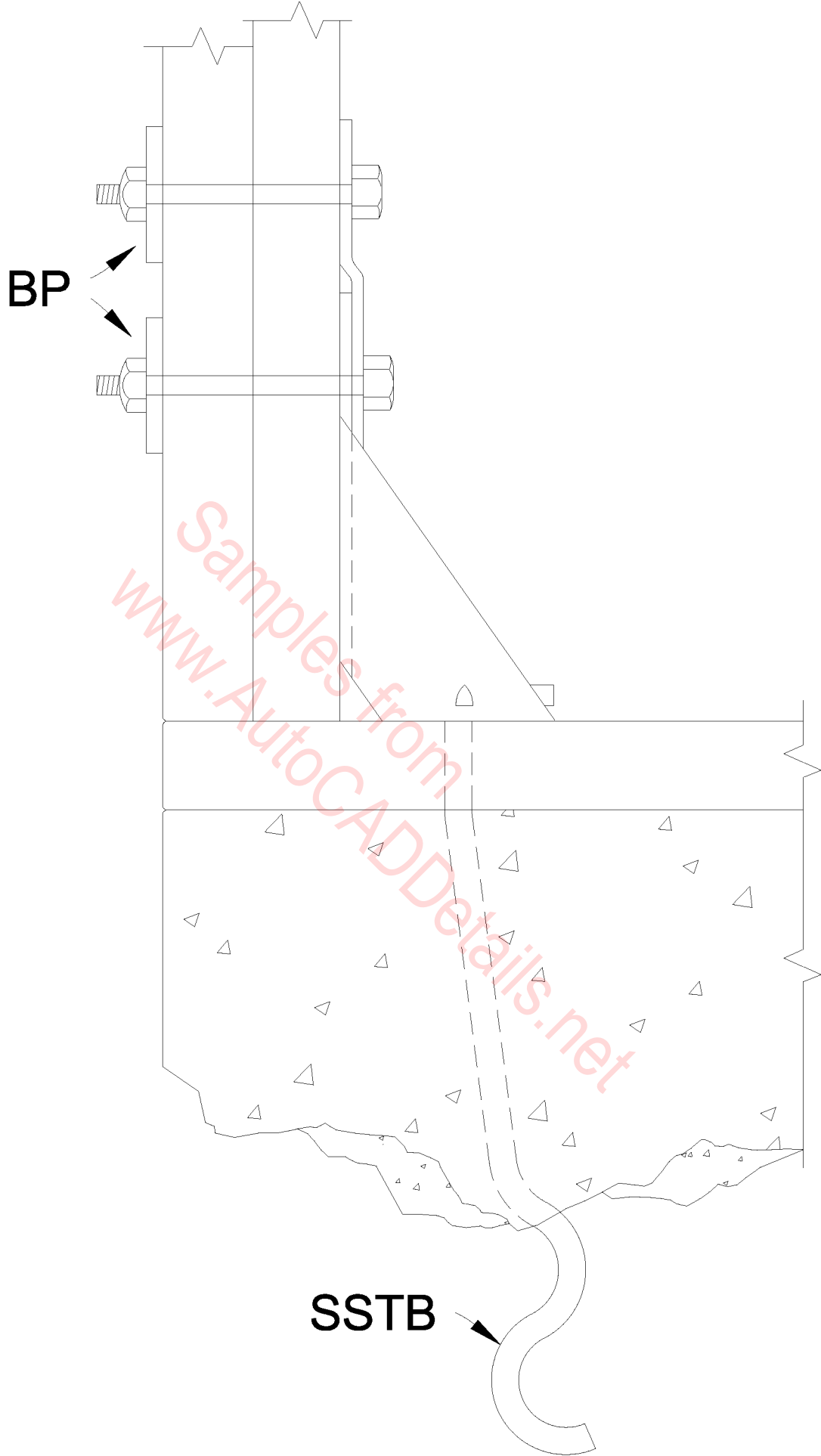

**Simpson Strong-Tie  
BP with SSTB**

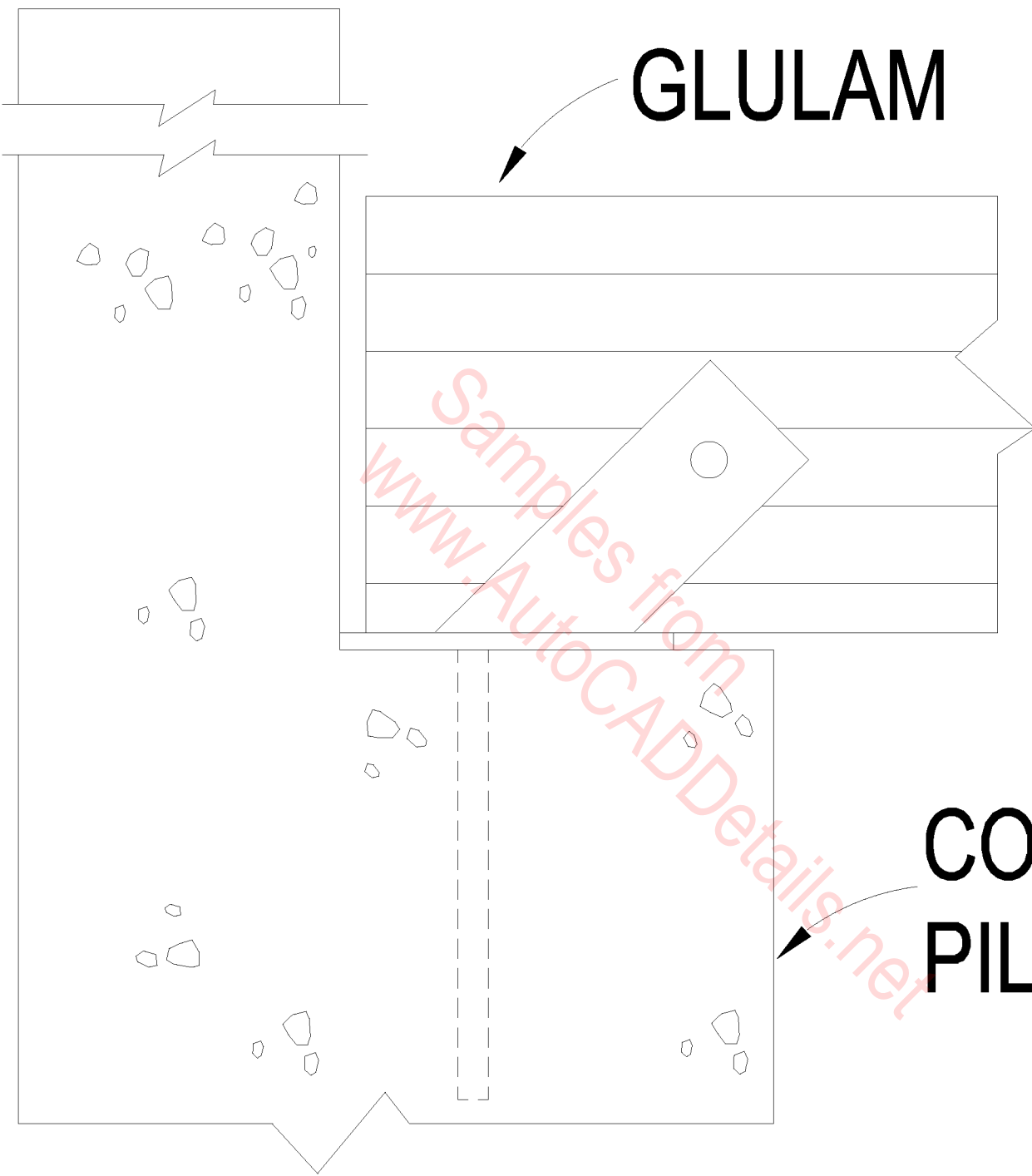

**GLULAM**

**CONCRETE  
PILASTER**

**Simpson Strong-Tie  
GLB**

*Samples from  
www.AutocADDetails.net*

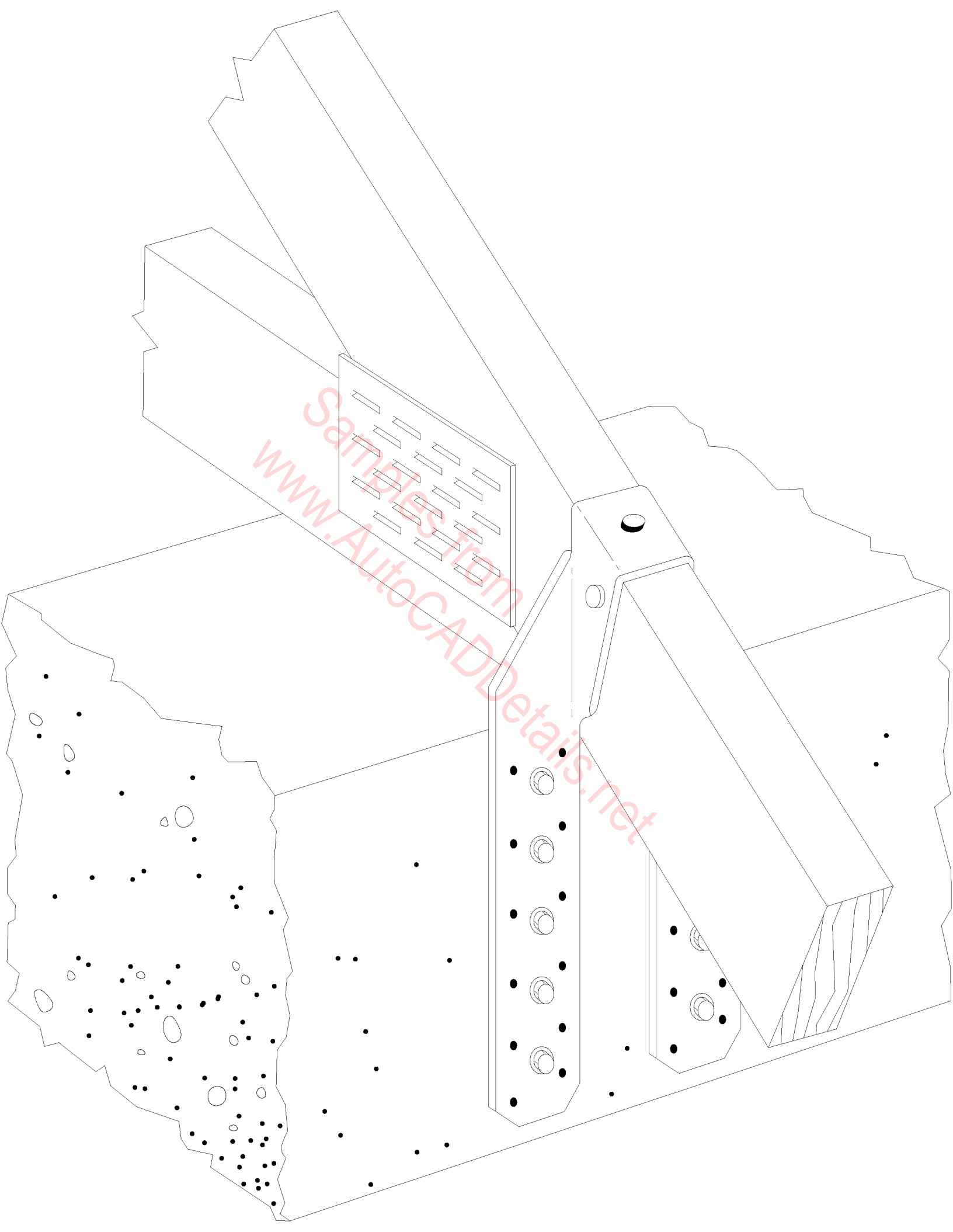

WASHERS  
MUST BE  
INSTALLED  
BETWEEN  
BOLT HEADS  
OR NUTS  
AND WOOD

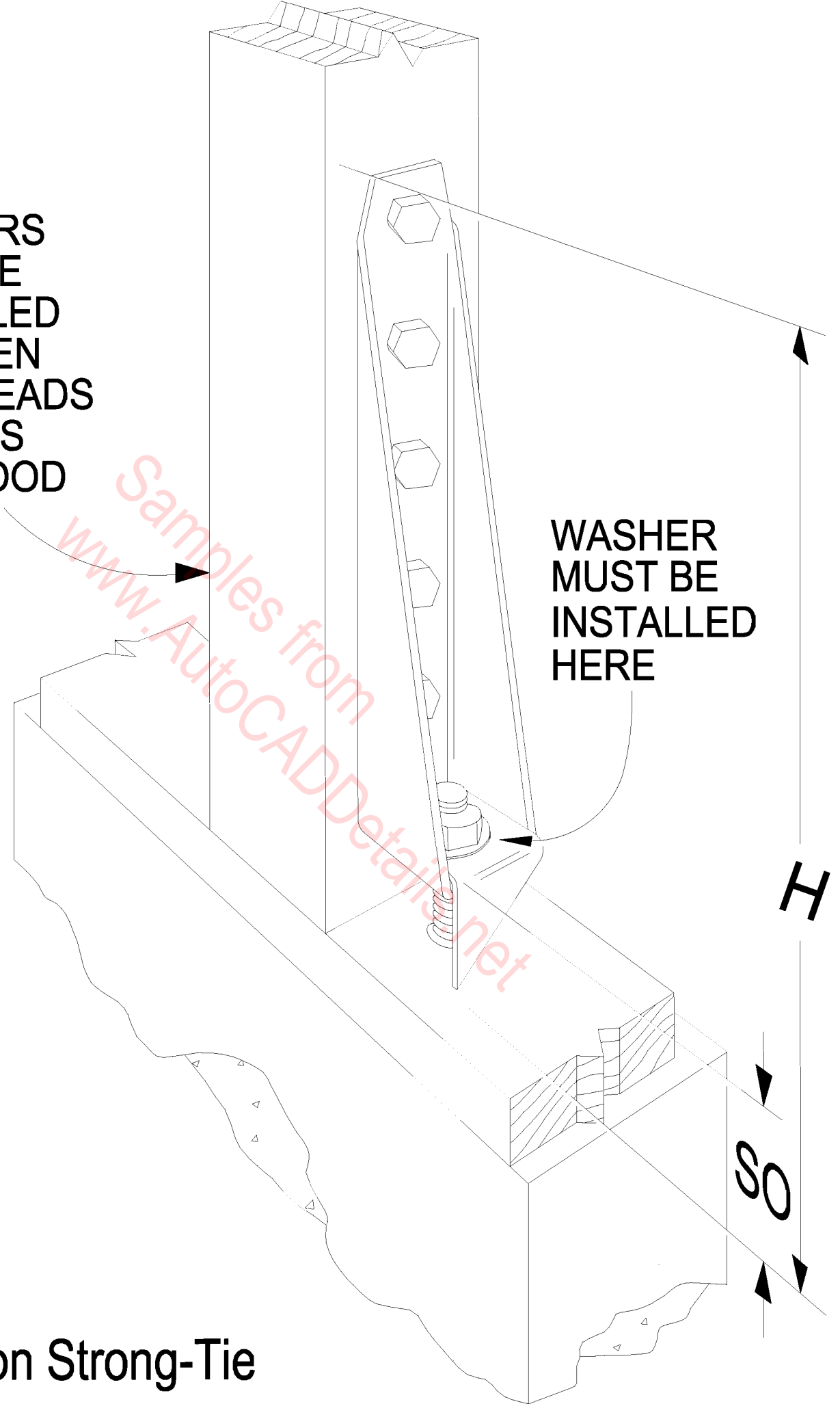

WASHER  
MUST BE  
INSTALLED  
HERE

Simpson Strong-Tie  
HD15

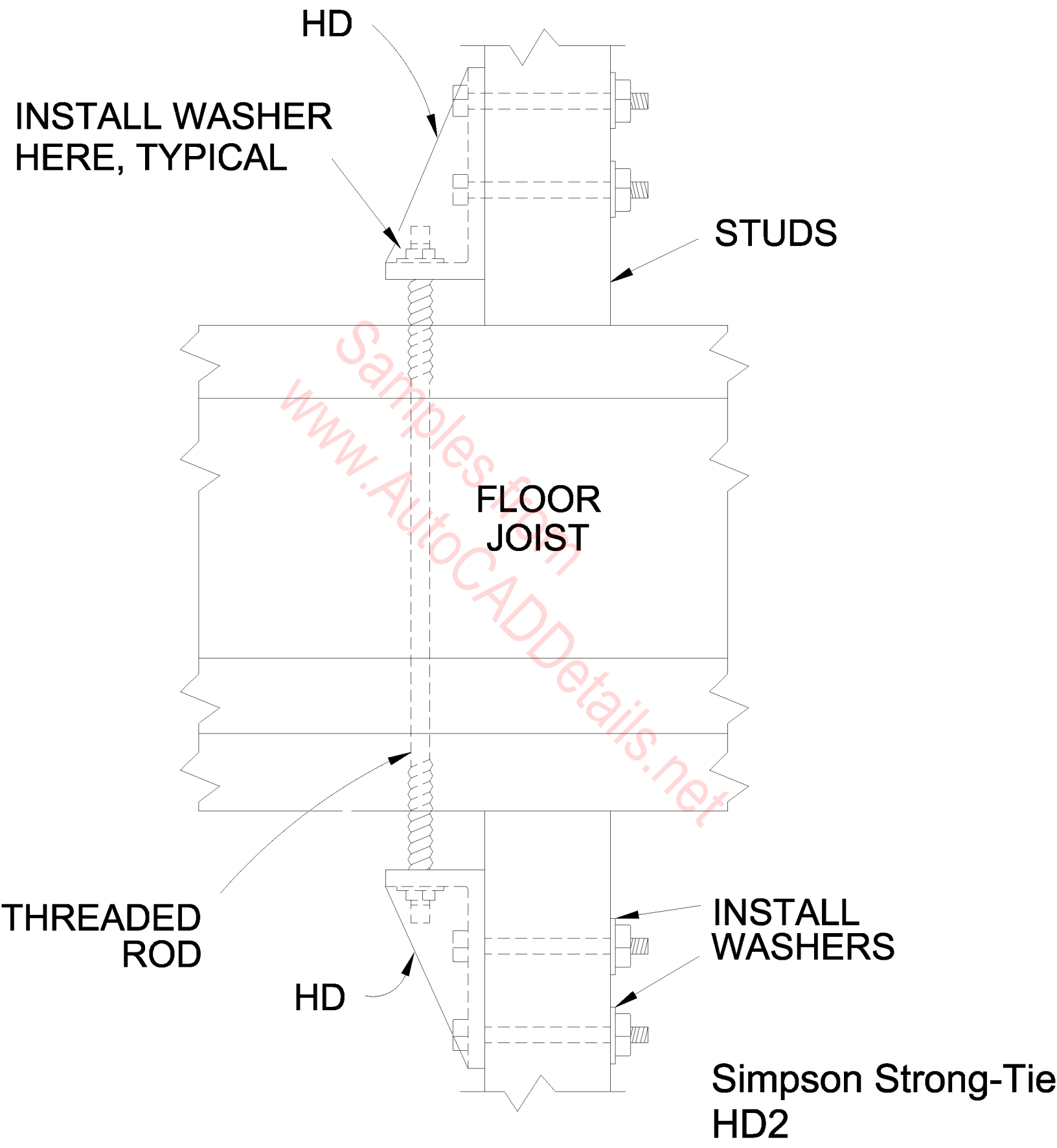

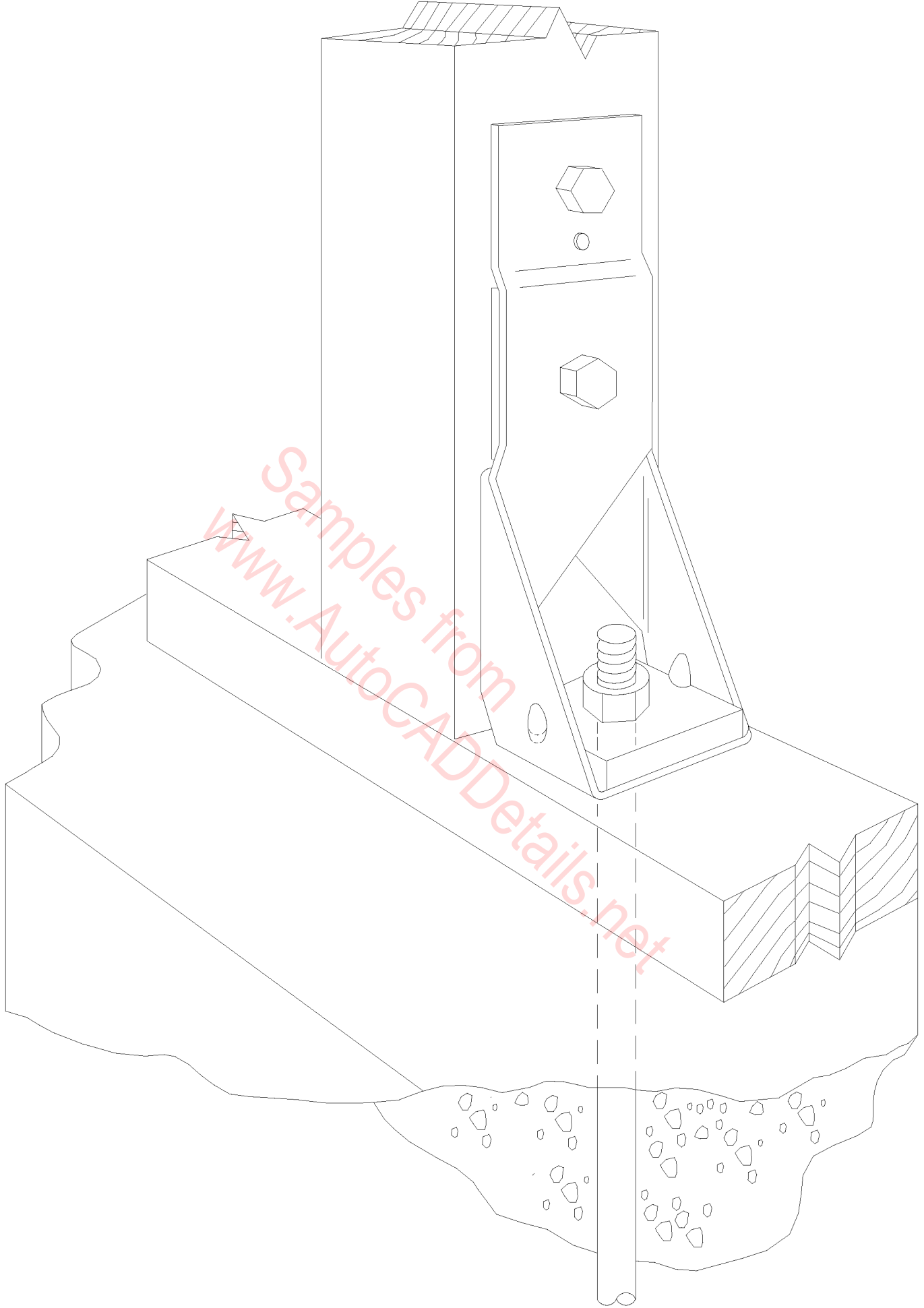

**Simpson Strong-Tie  
HD5A**



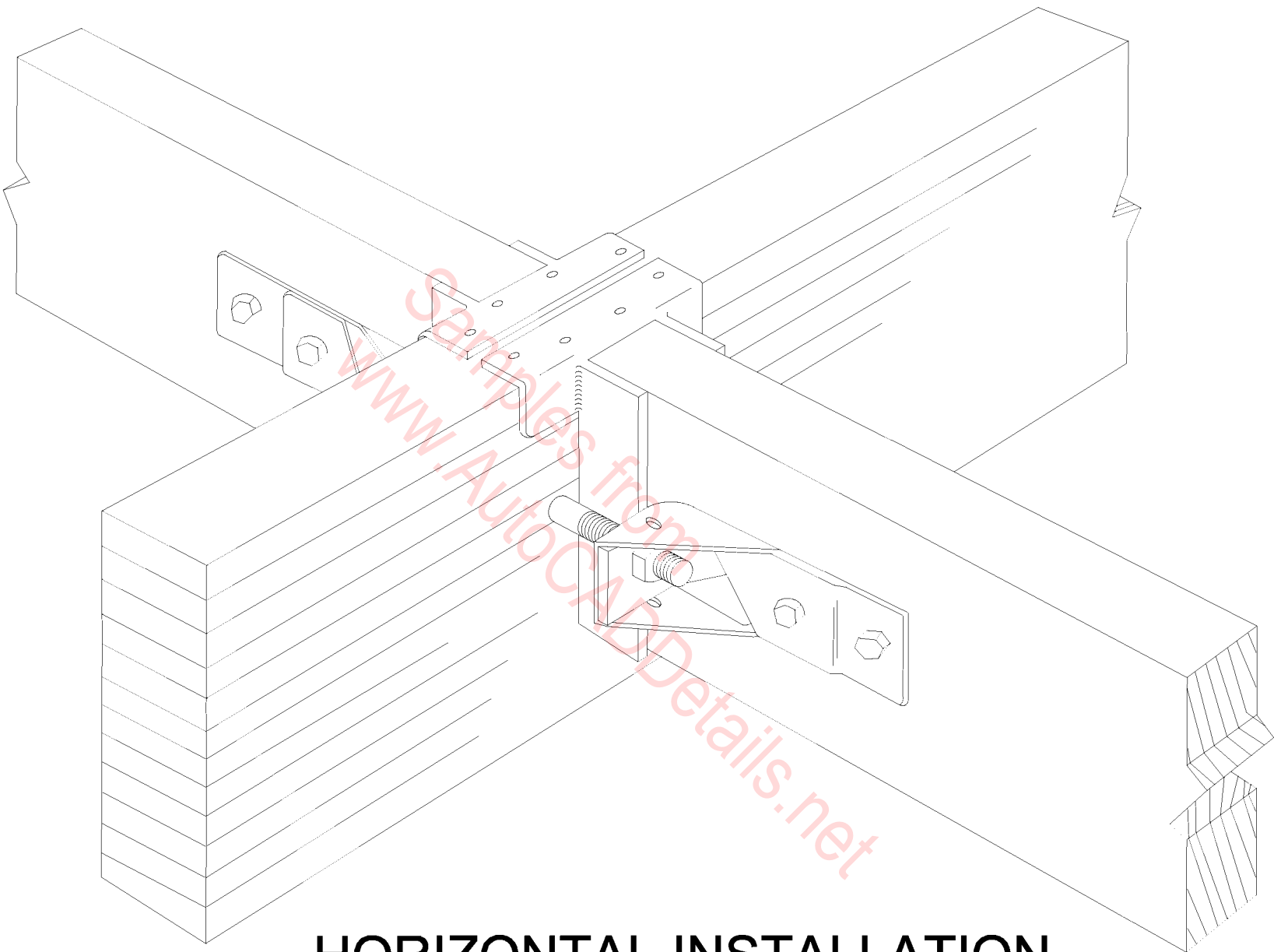

## HORIZONTAL INSTALLATION

**Simpson Strong-Tie  
HD5A**

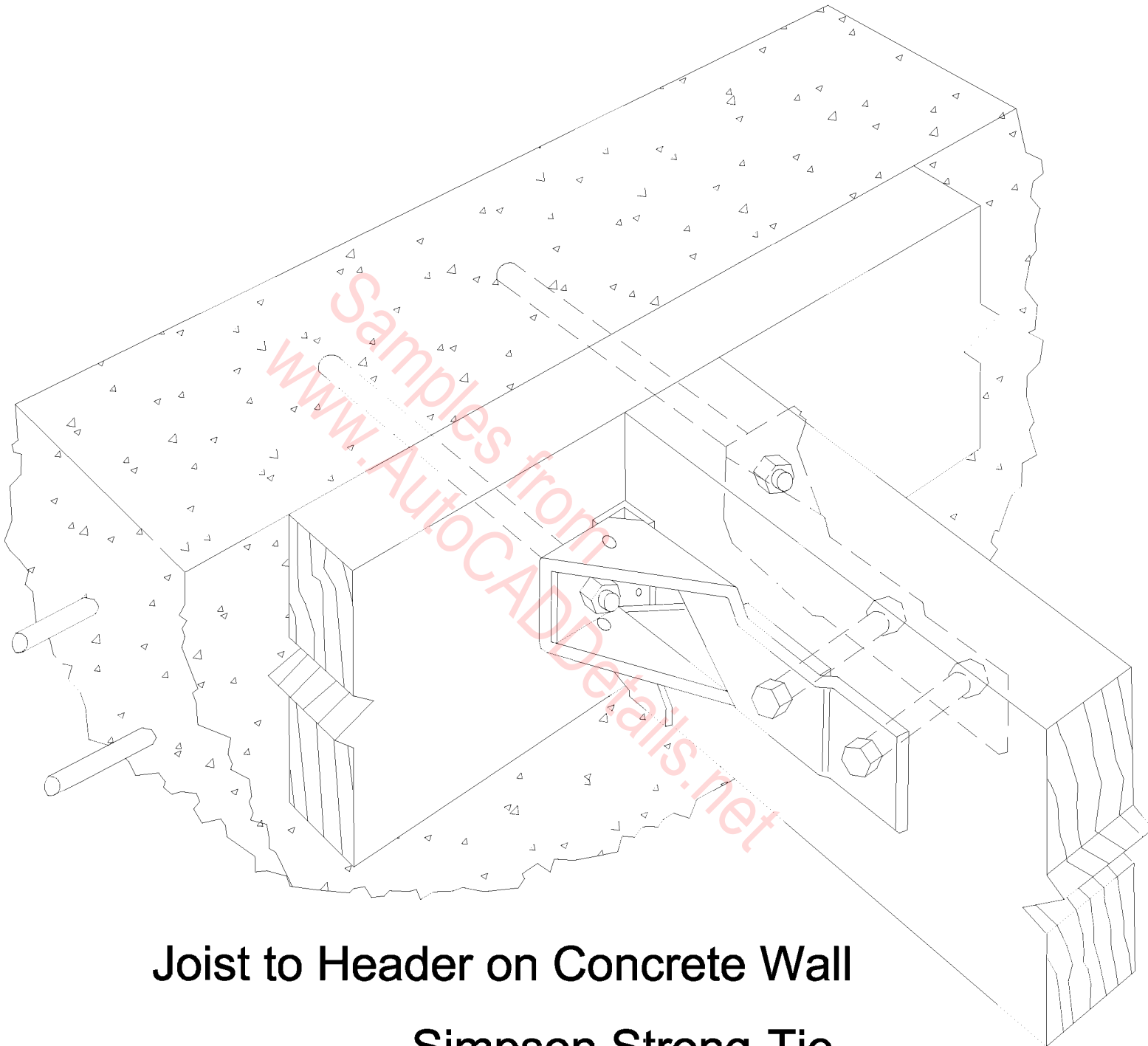

## Joist to Header on Concrete Wall

Simpson Strong-Tie  
HD5A with HU48

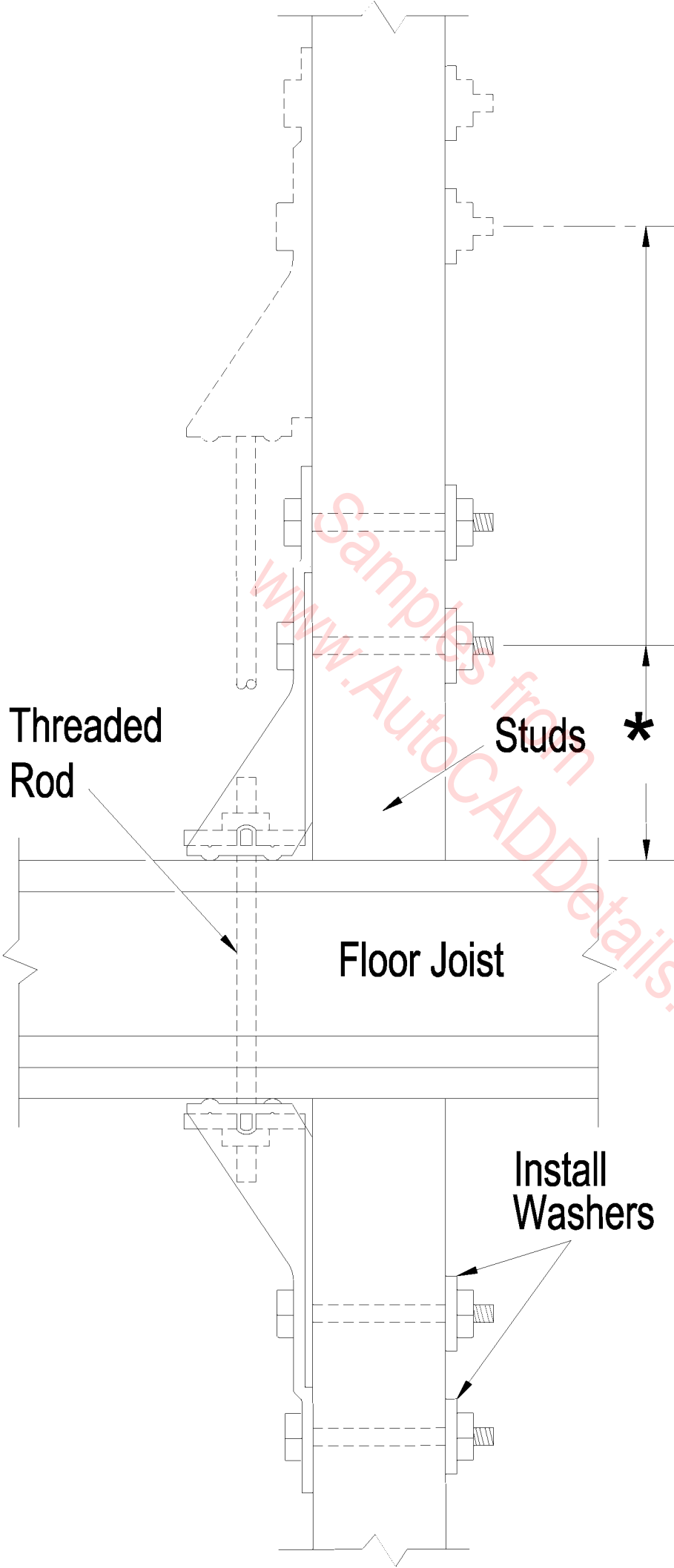

\* Minimum of seven bolt diameters to achieve table loads. This distance is designed into holdown. Distance may be increased without affecting load capacity, provided the anchor nut is not over-torqued, which could split the stud.

Simpson Strong-Tie  
HD5A

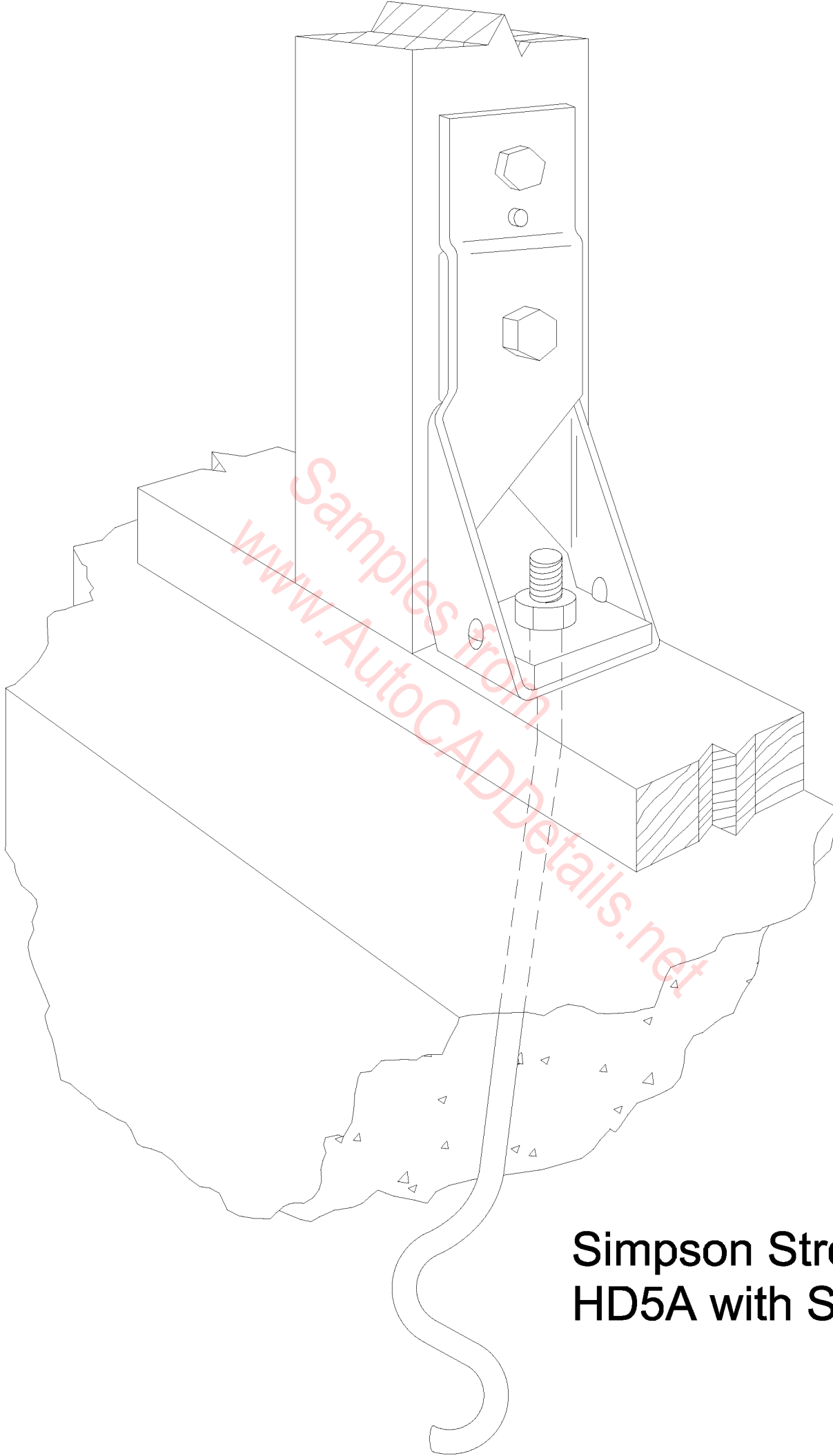

**Simpson Strong-Tie  
HD5A with SSTB**

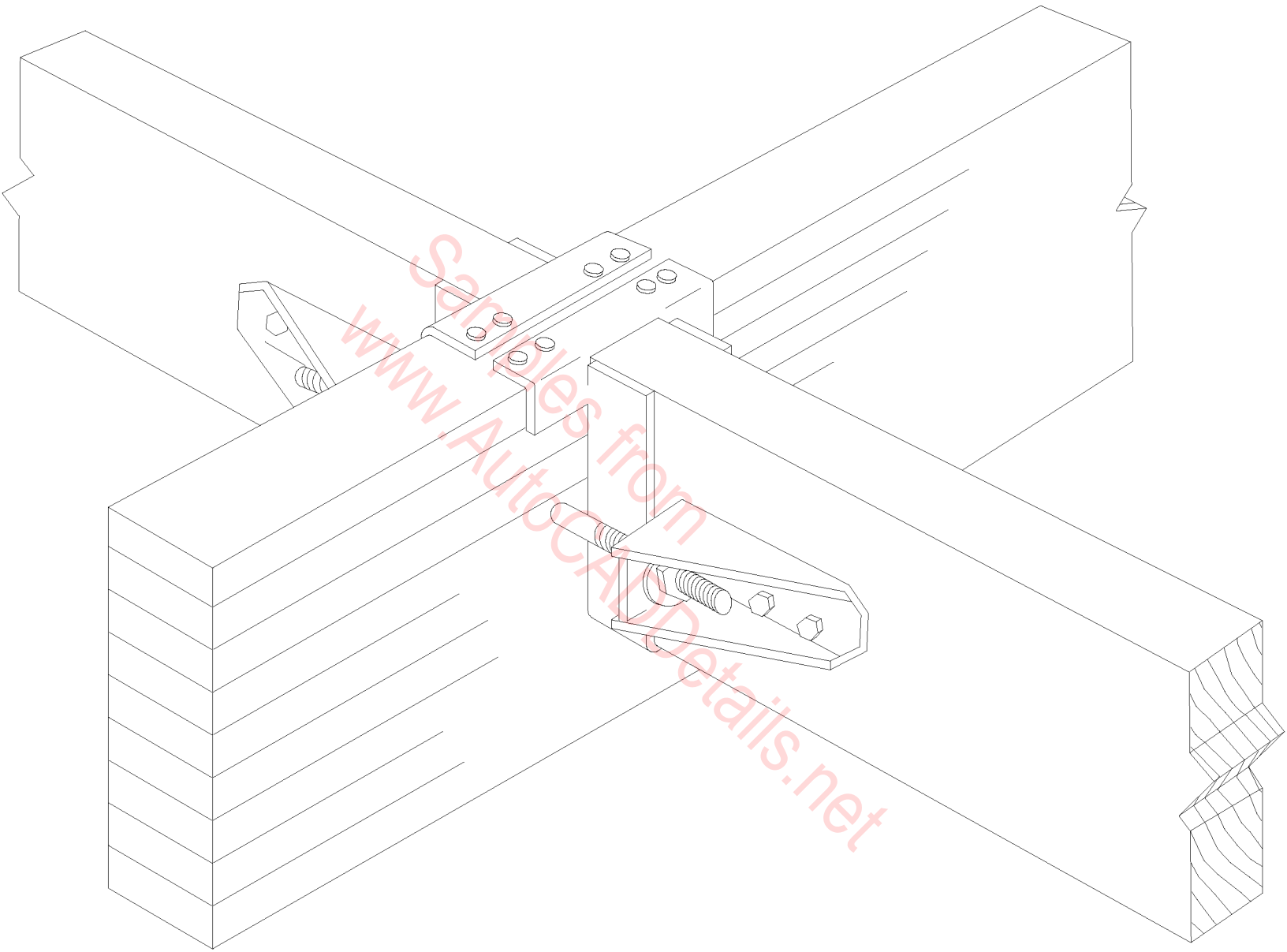

**Simpson Strong-Tie  
HD5**

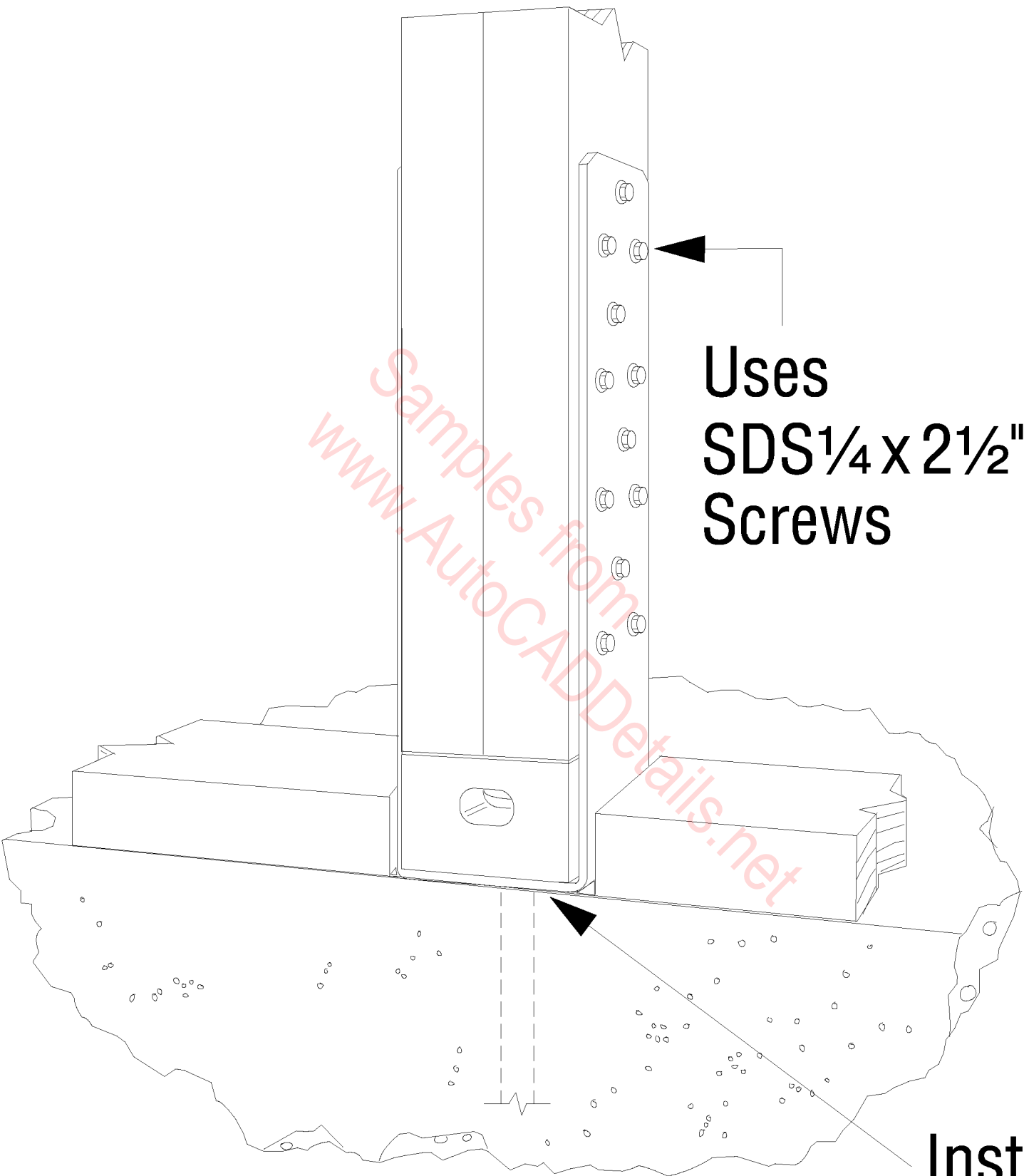

Uses  
SDS  $\frac{1}{4}$  x  $2\frac{1}{2}$ "  
Screws

Install on  
Concrete

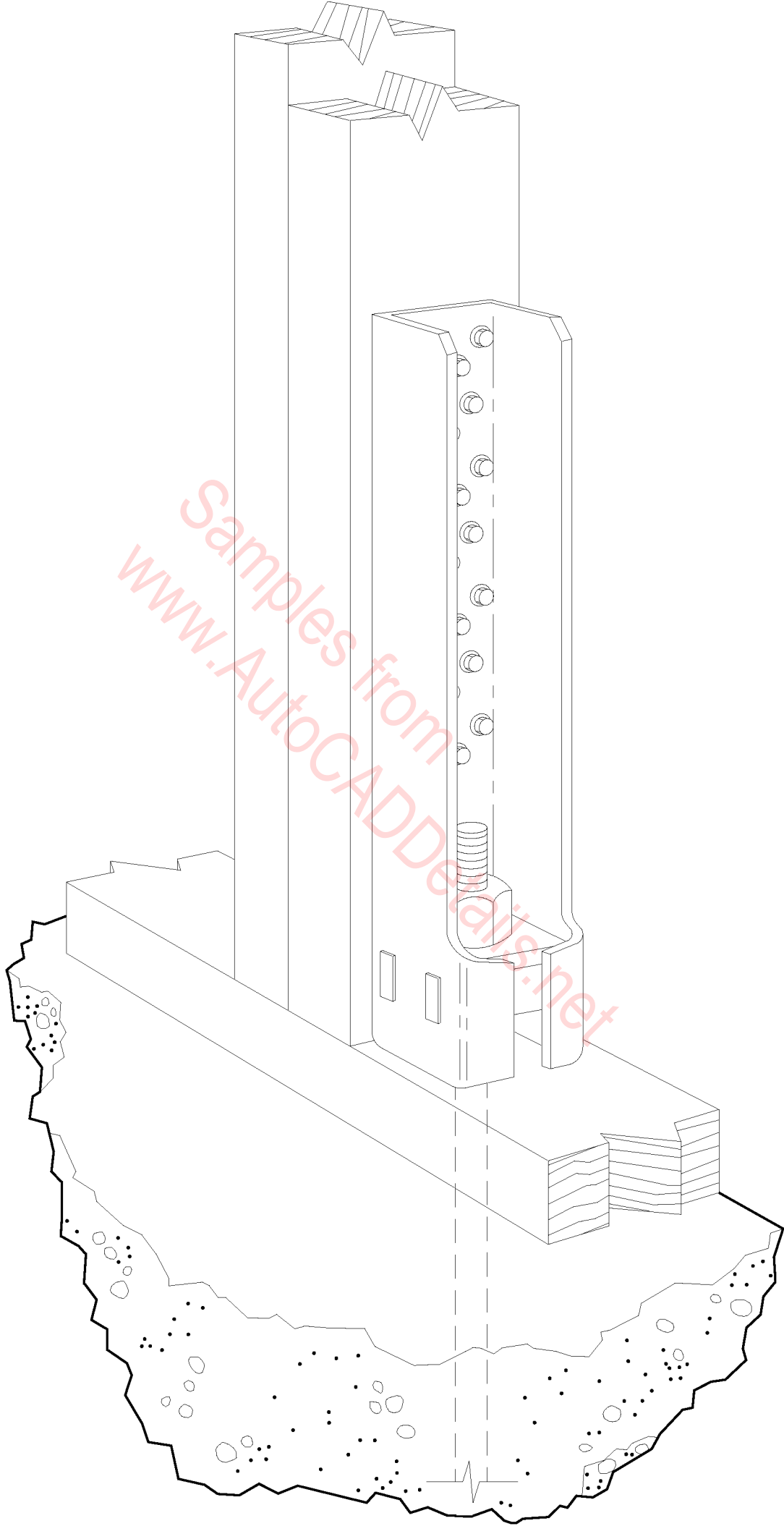

2 x EMBEDMENT LENGTH  
+ 12" MINIMUM  
REBAR LENGTH

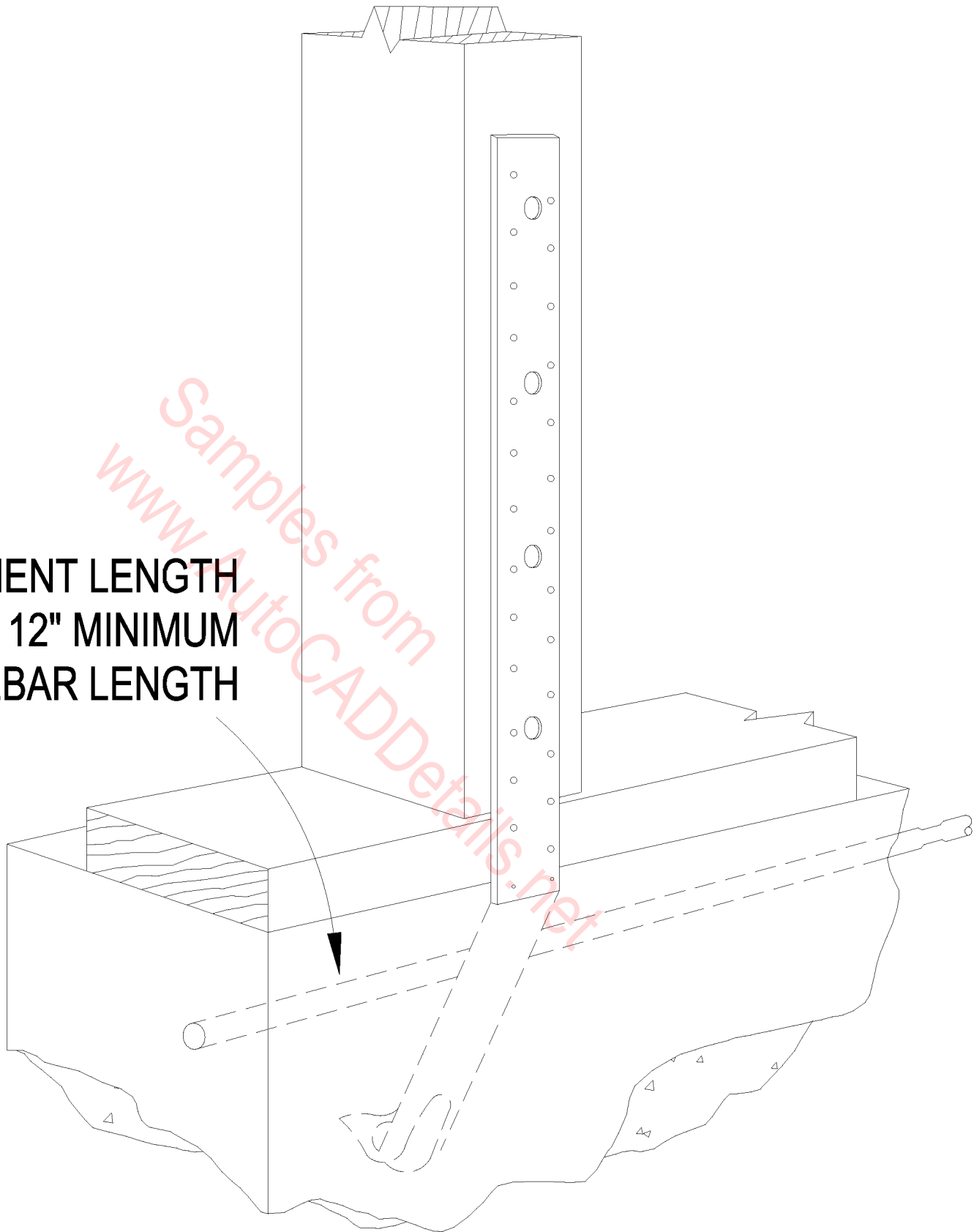

**Simpson Strong-Tie  
HPAHD22**



**SINGLE POUR  
CORNER  
INSTALLATION**

**ONE #4  
REBAR IN  
SHEAR CONE**

**12" MINIMUM  
REBAR LENGTH**

**CORNER  
DISTANCE  
FROM EDGE  
OF STRAP TO  
CORNER**

**30" MINIMUM  
REBAR LENGTH**

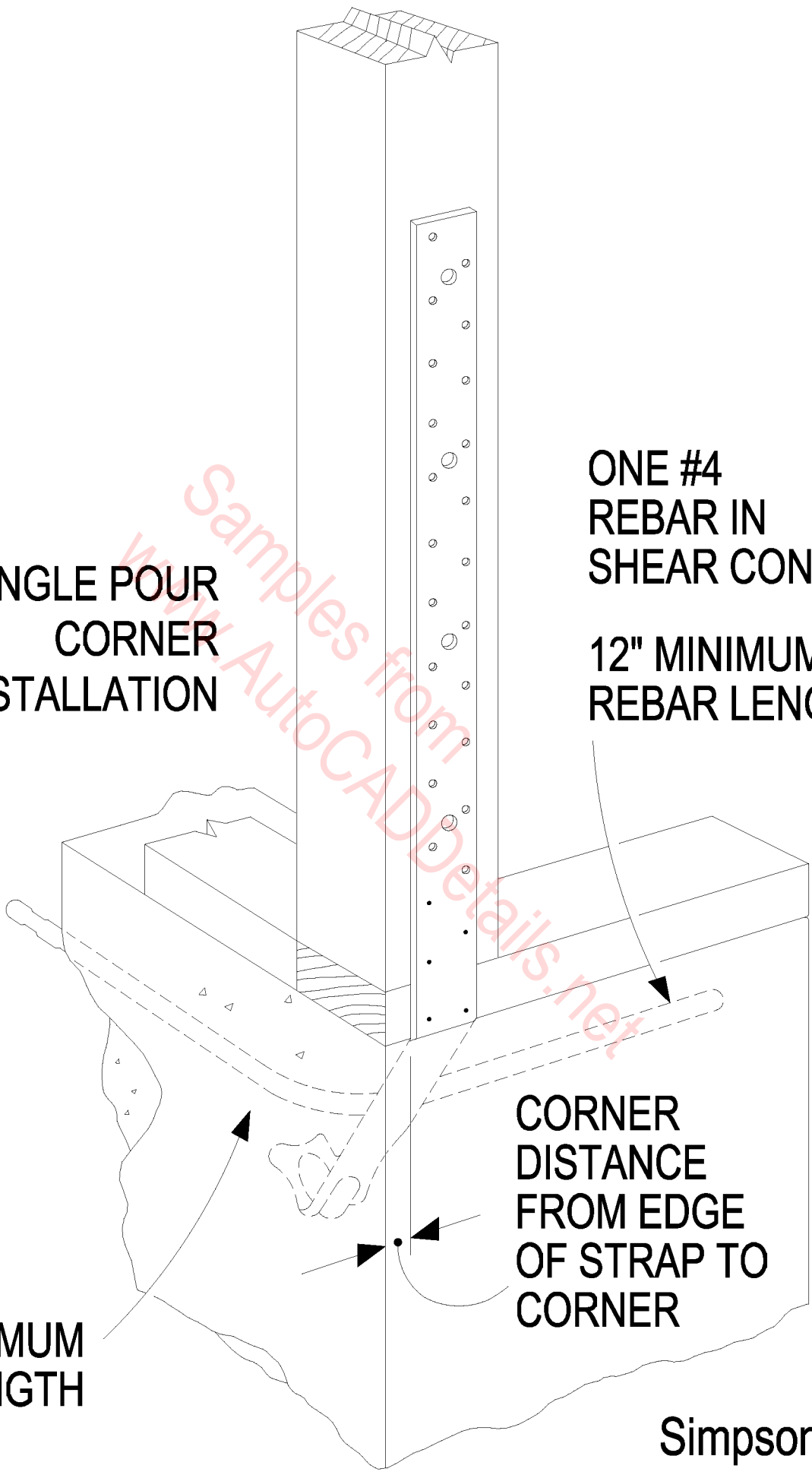

**Simpson Strong-Tie  
HPAHD**

**SINGLE POUR  
RIM JOIST  
INSTALLATION**

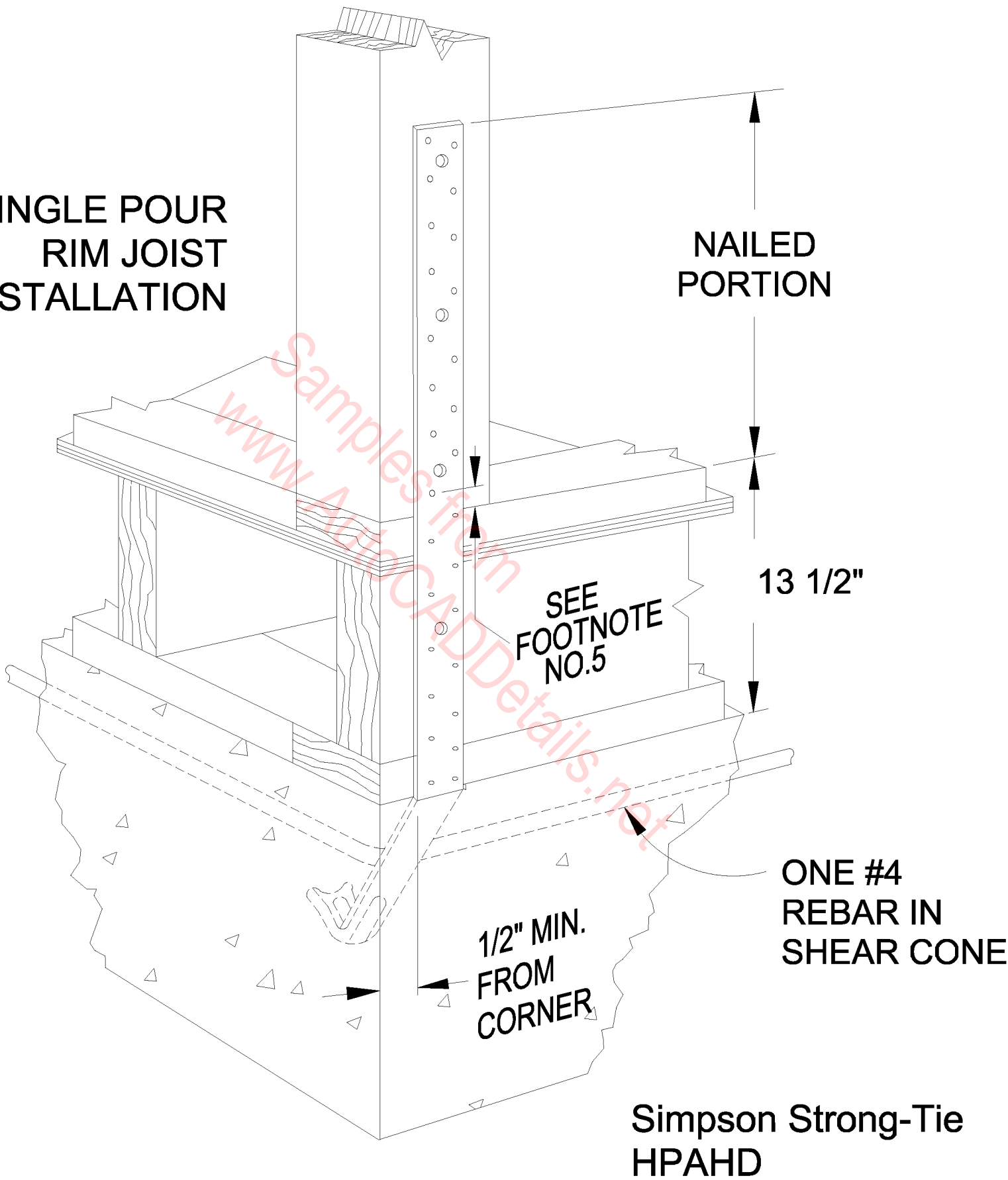

**NAILED  
PORTION**

**13 1/2"**

**SEE  
FOOTNOTE  
NO.5**

**ONE #4  
REBAR IN  
SHEAR CONE**

**1/2" MIN.  
FROM  
CORNER**

**Simpson Strong-Tie  
HPAHD**

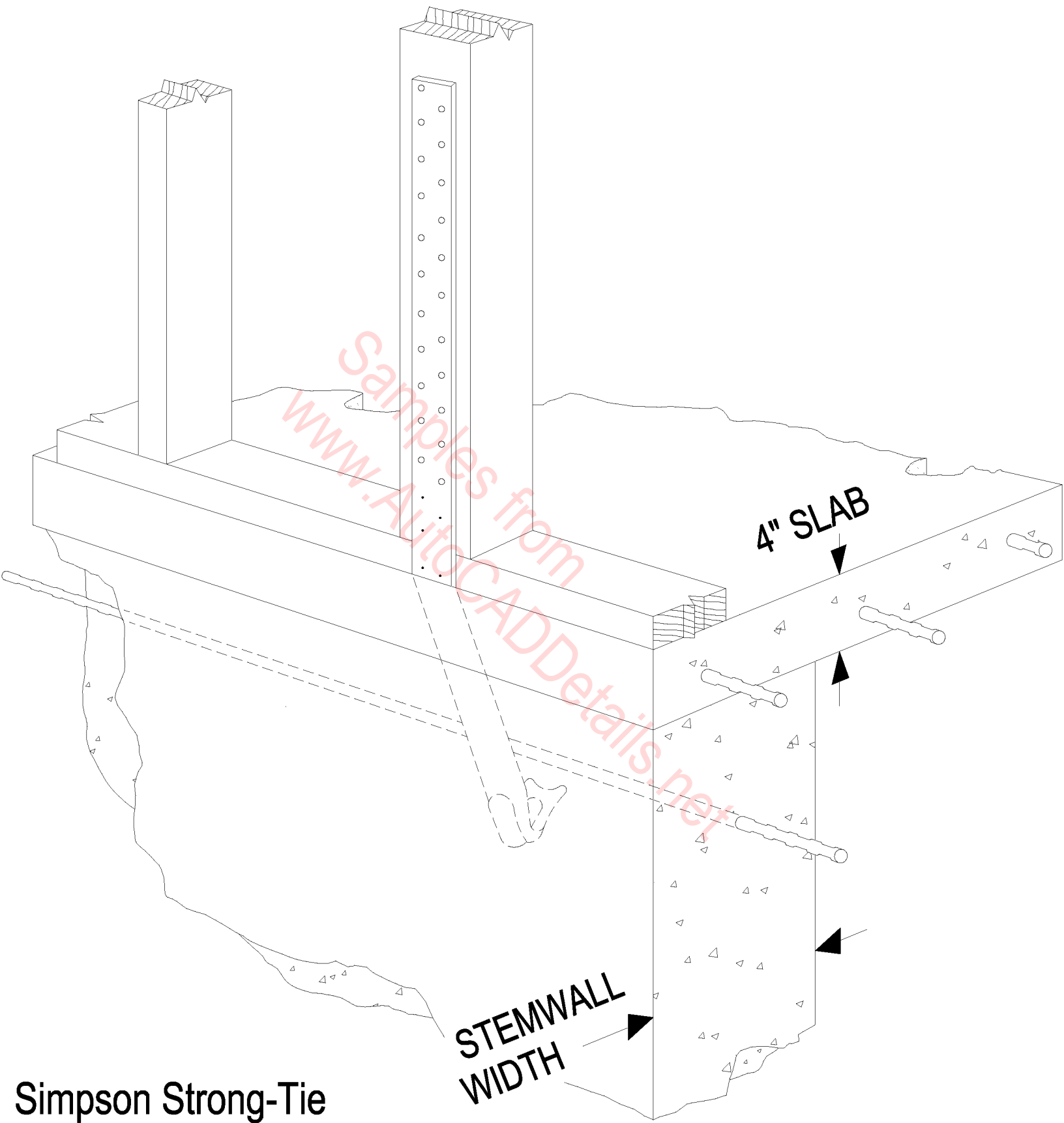

Simpson Strong-Tie  
HPAHD22-2P

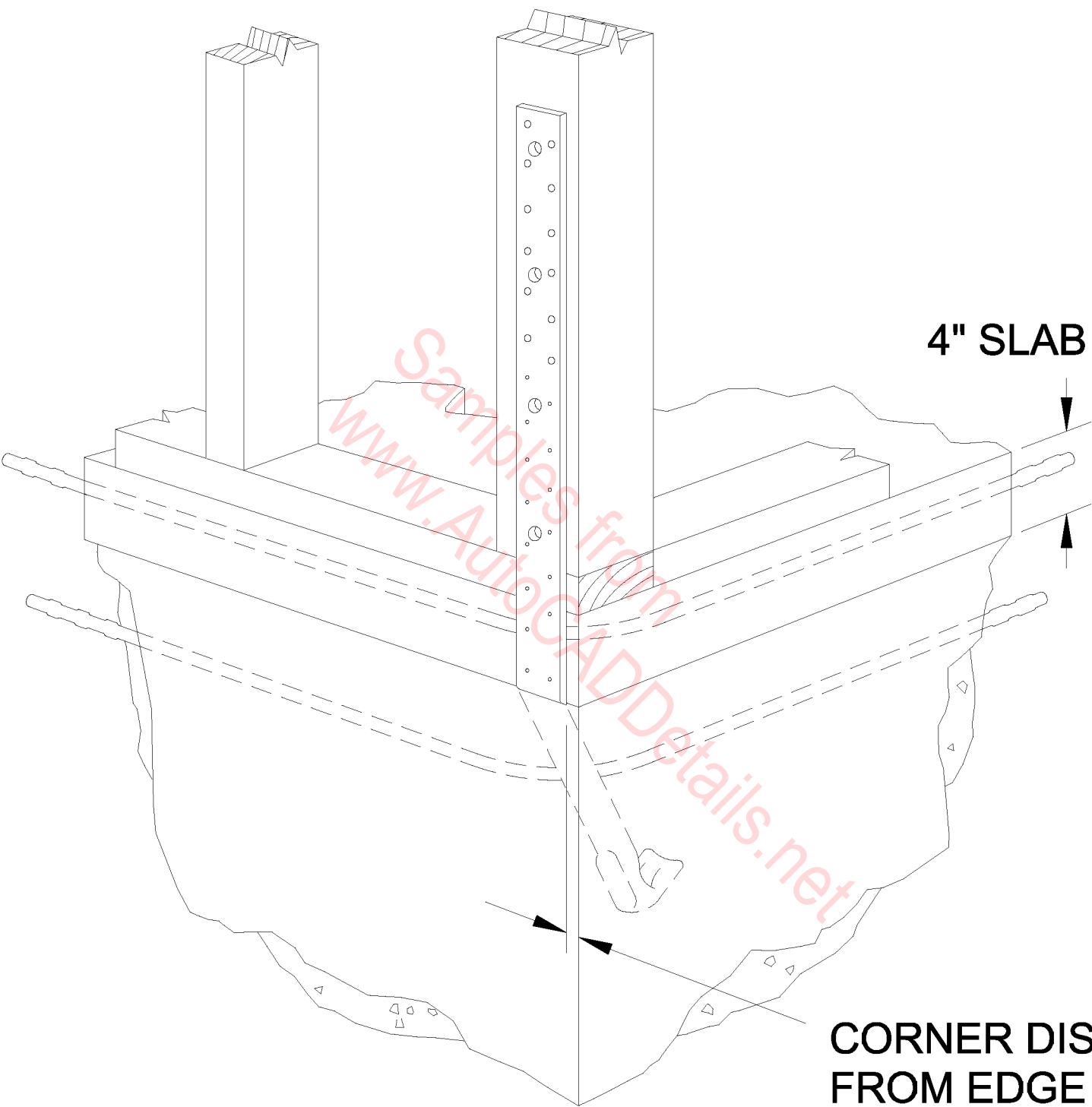

4" SLAB

CORNER DISTANCE  
FROM EDGE OF  
STRAP TO  
CORNER

Simpson Strong-Tie  
HPAHD22

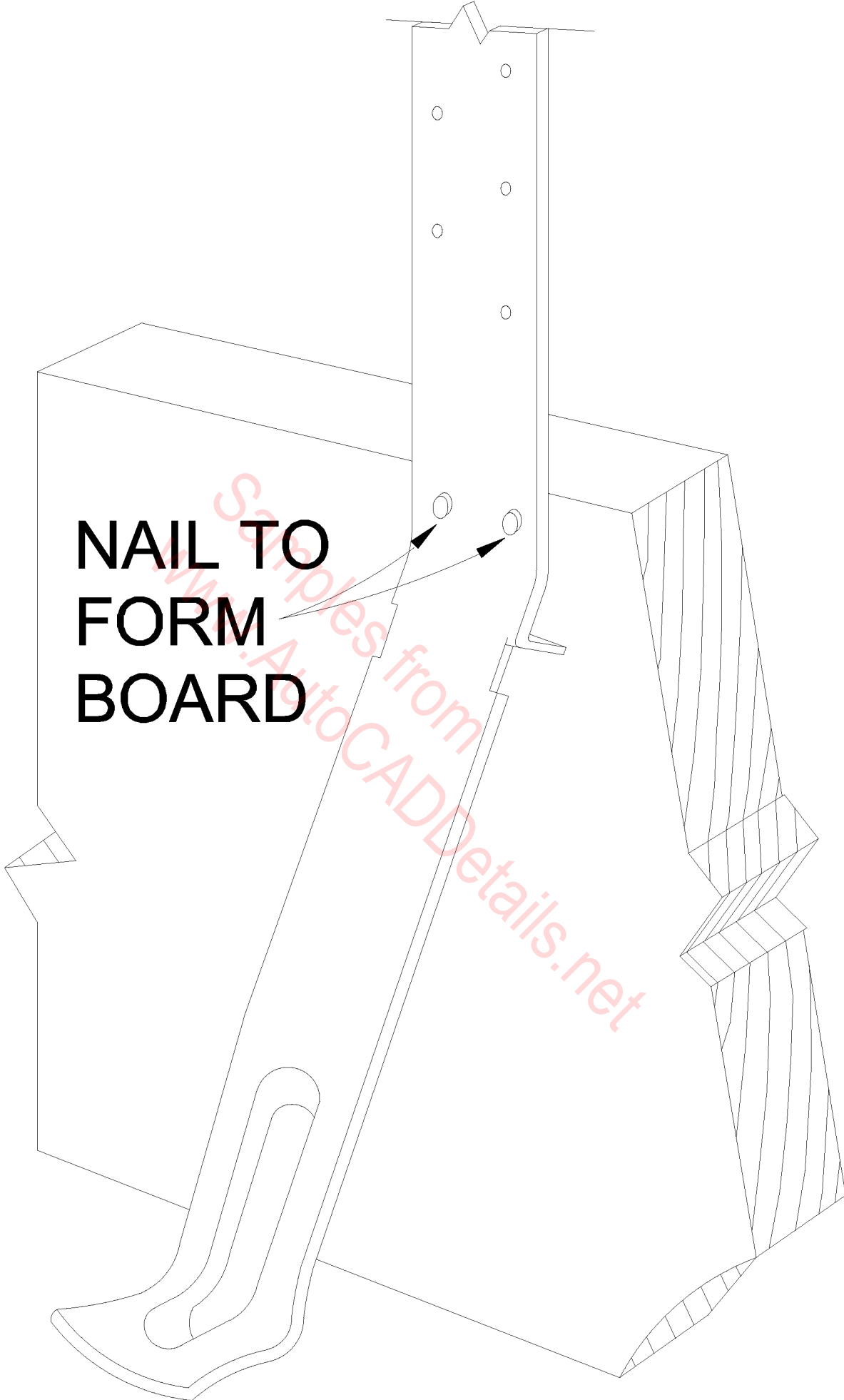

**NAIL TO  
FORM  
BOARD**

**Simpson Strong-Tie  
HPAHD22-2P**

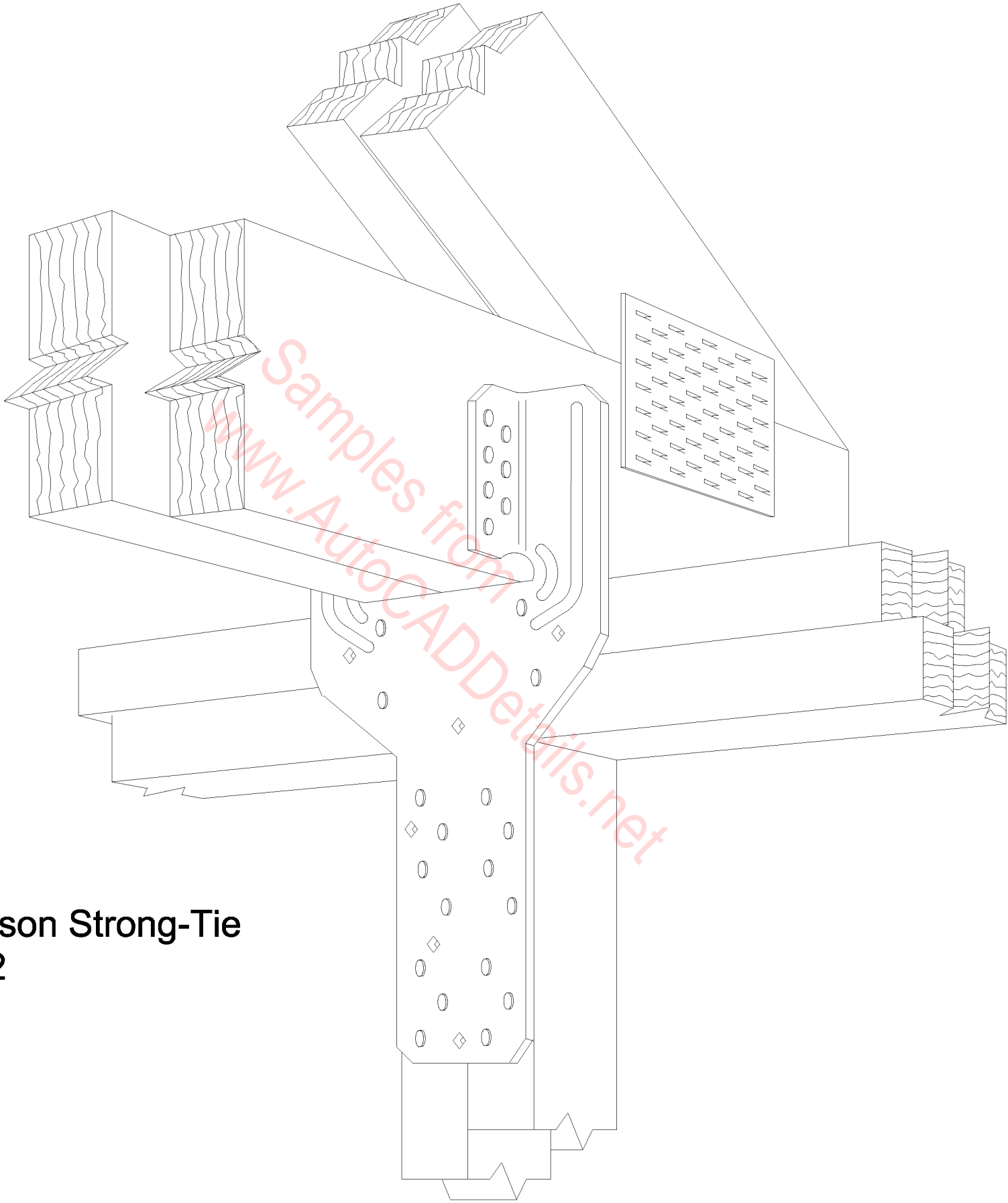

**Simpson Strong-Tie  
LGT2**

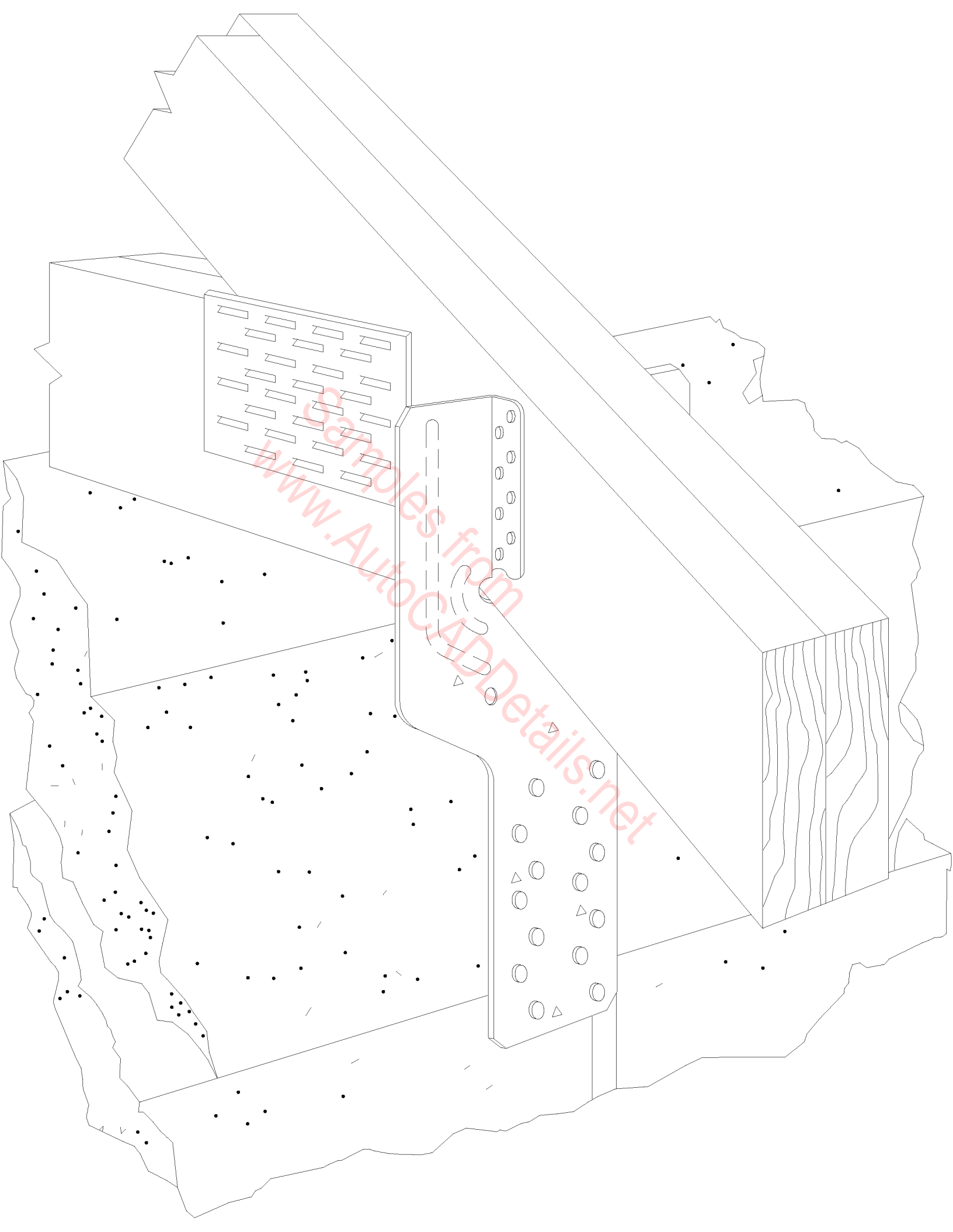

Simpson Strong-Tie  
LTA1

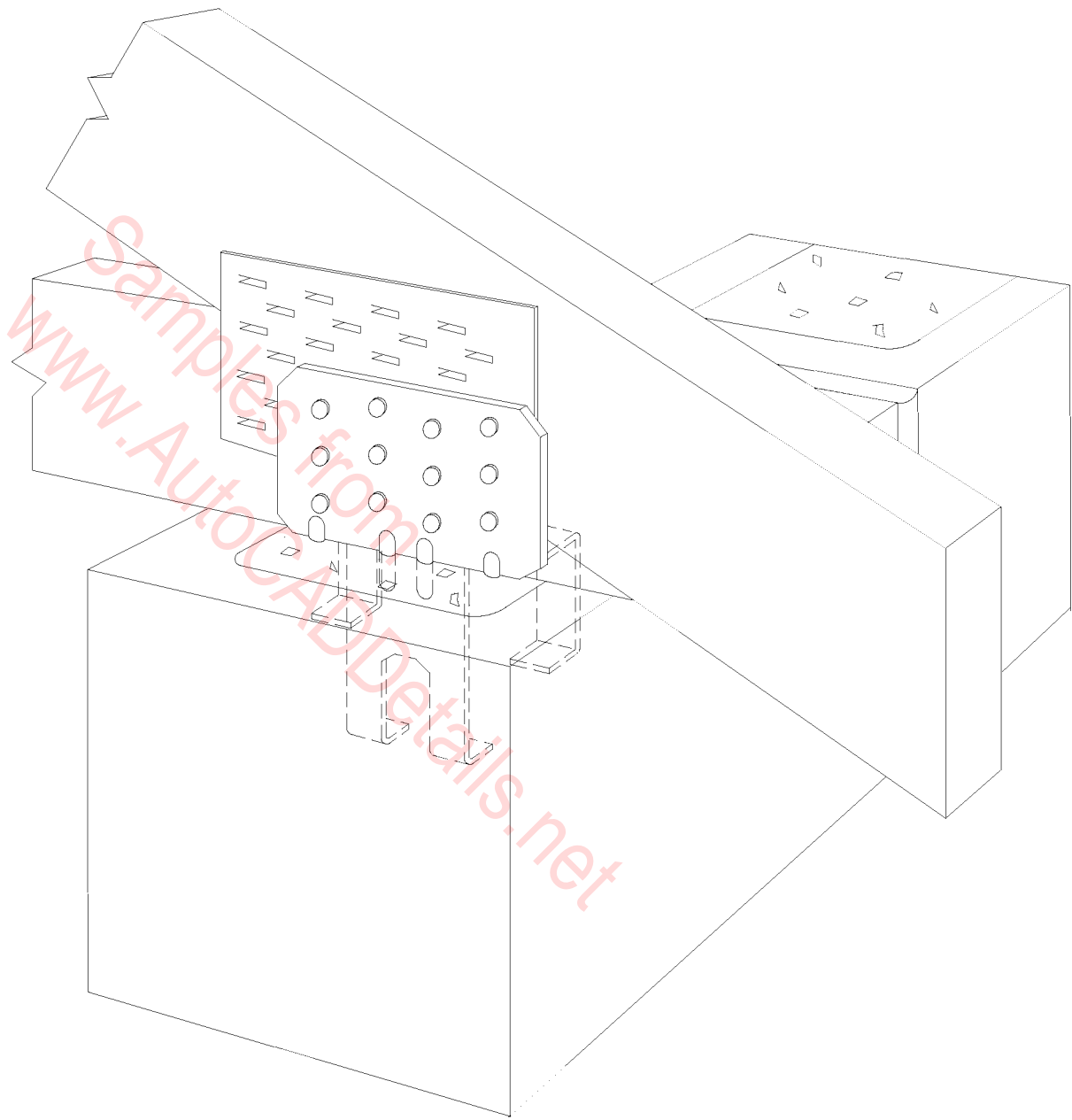



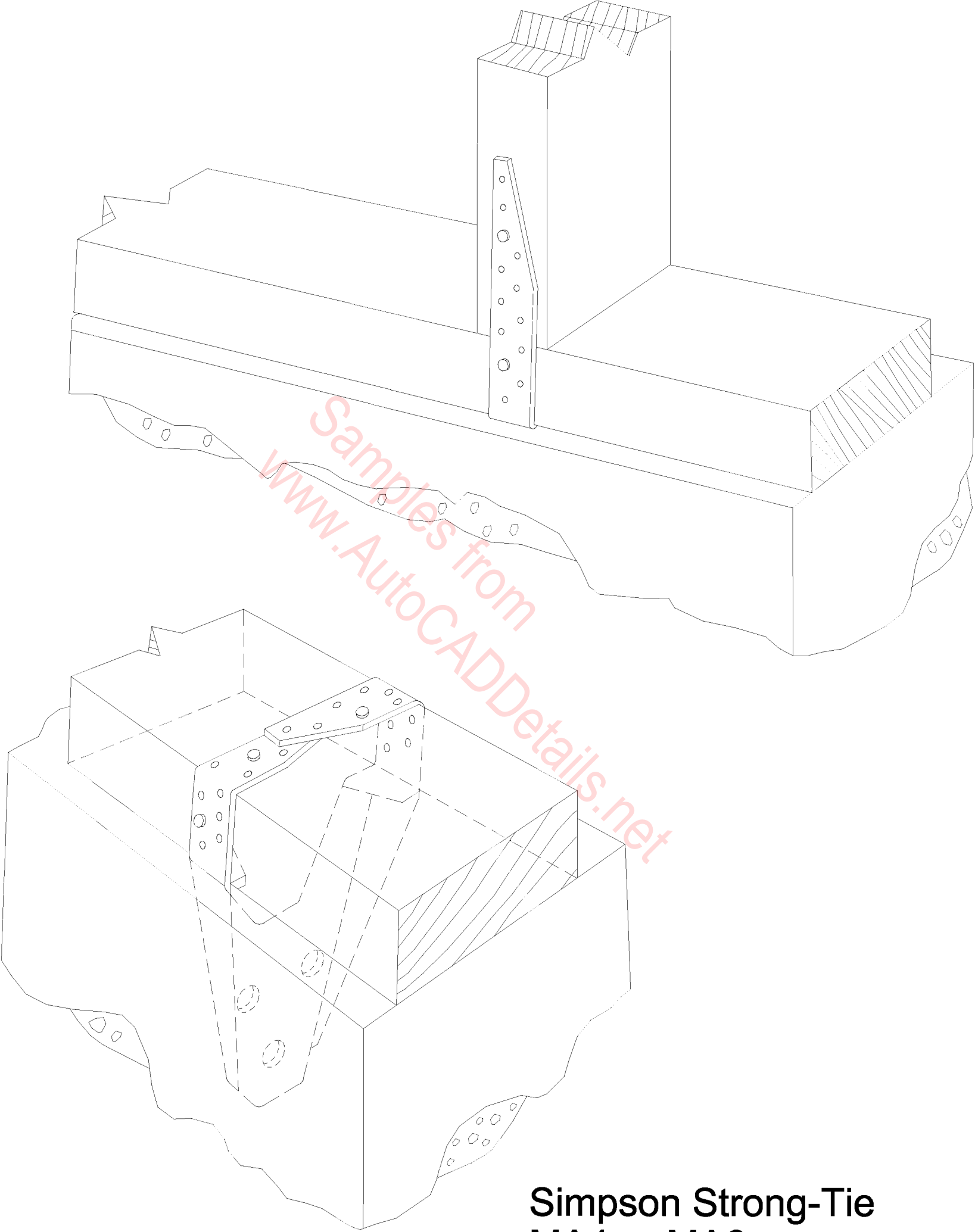

**Simpson Strong-Tie  
MA4 or MA6**

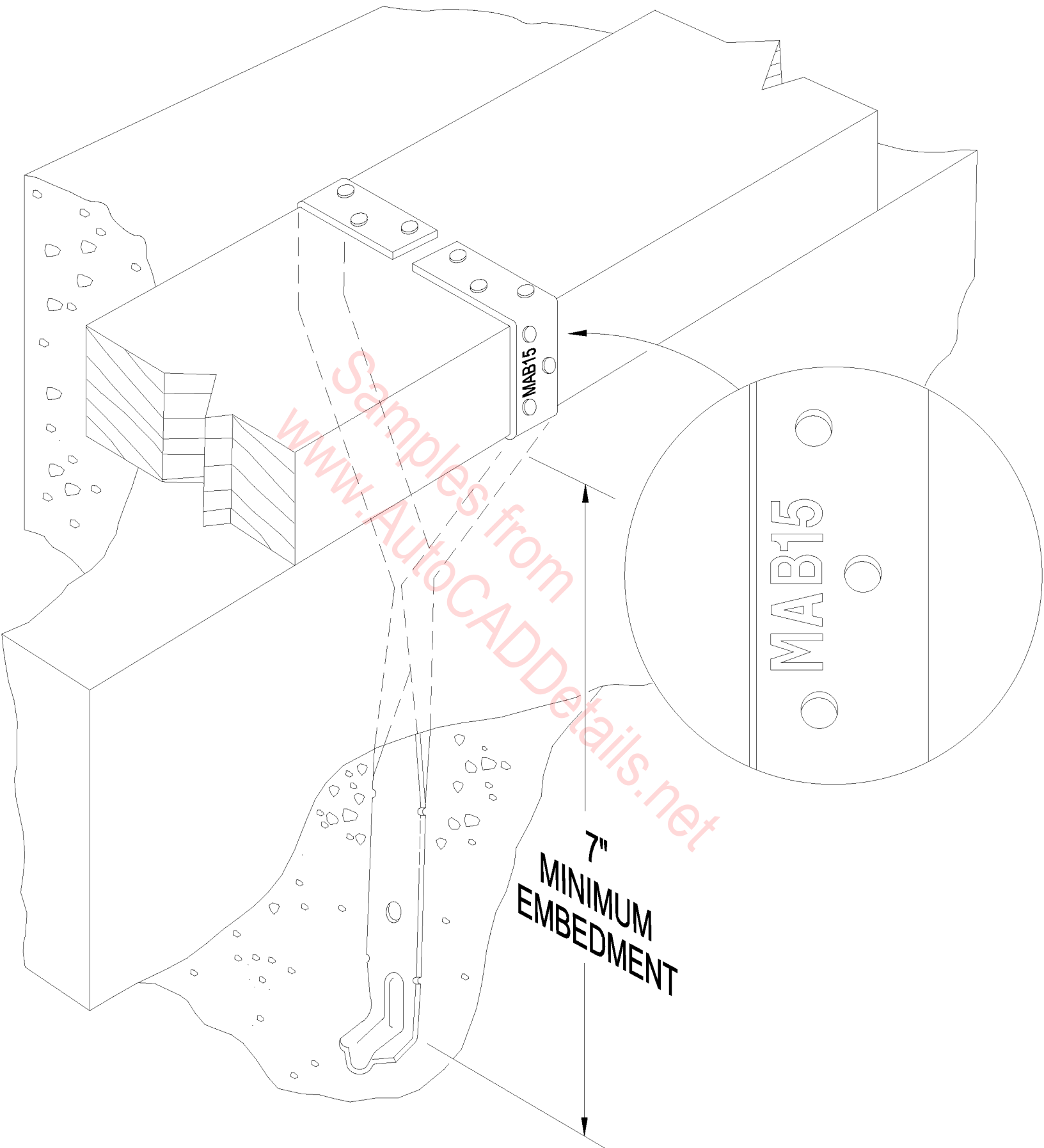

**Simpson Strong-Tie  
MAB15**

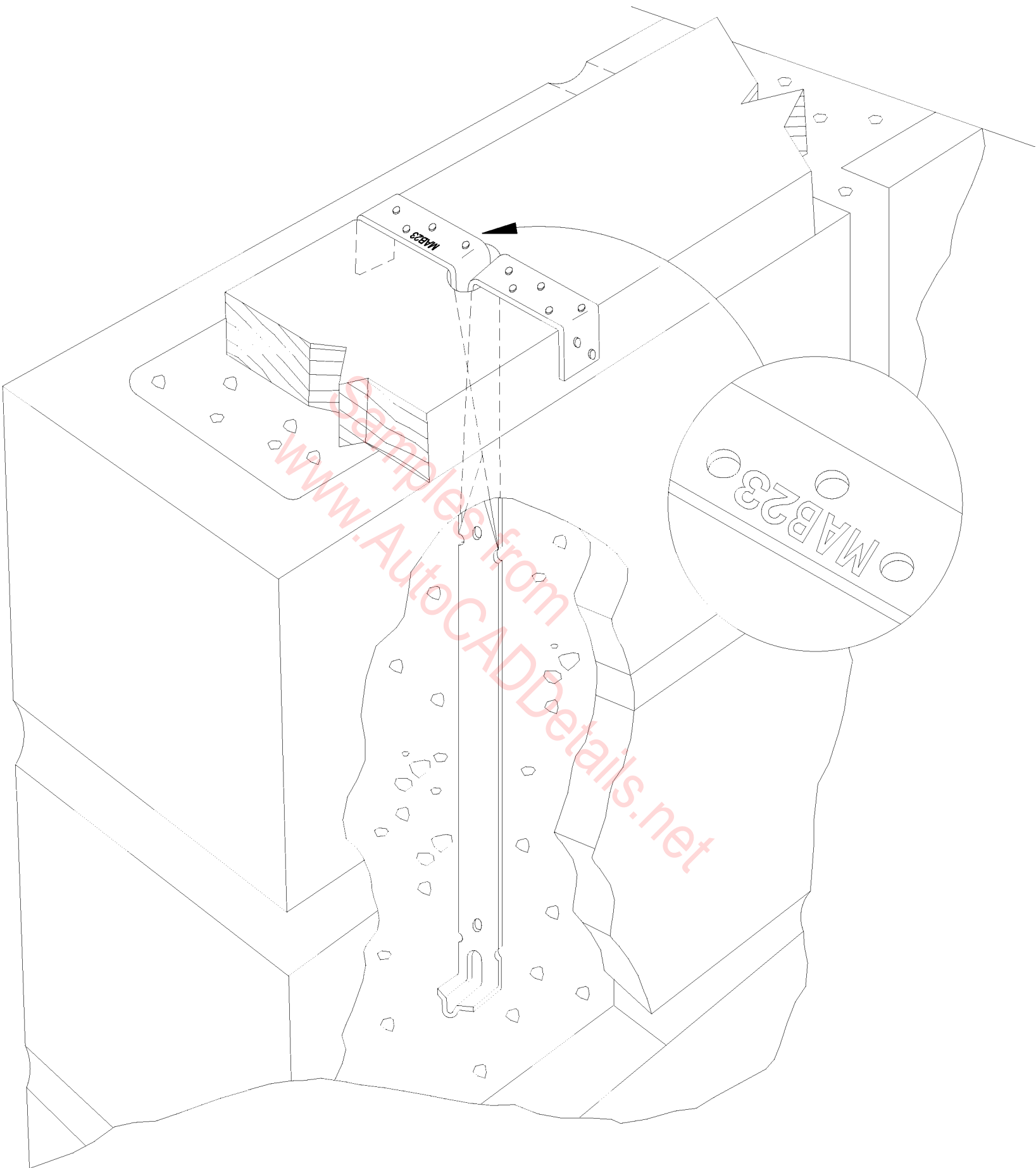

**Simpson Strong-Tie  
MAB23**

**2x4 OR 2x6  
MUDSILL**

**Simpson Strong-Tie  
MAS**

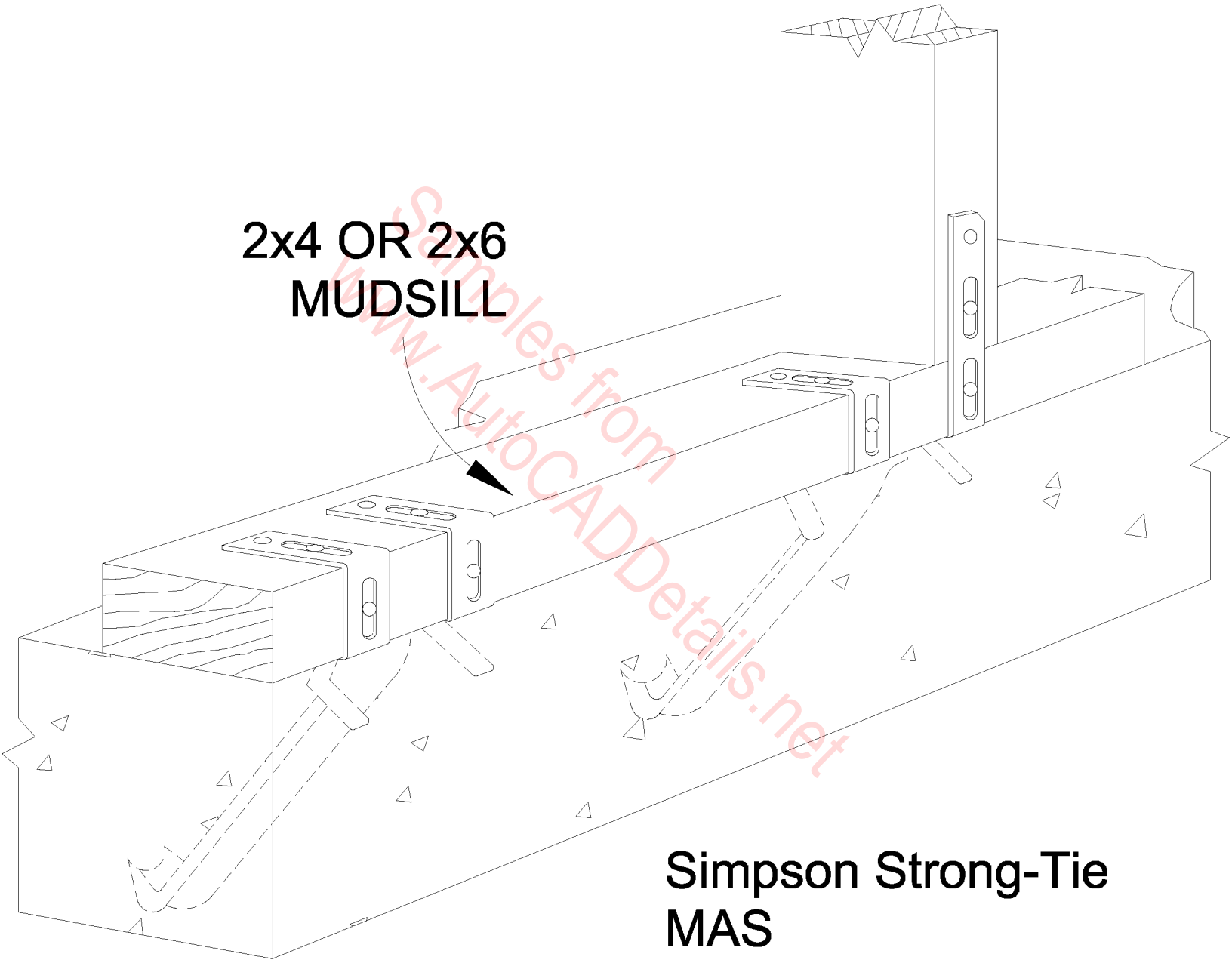

**FOR INSTALLATION EASE,  
NAIL ONE DUPLEX NAIL INTO  
SIDE FORM BOARD**

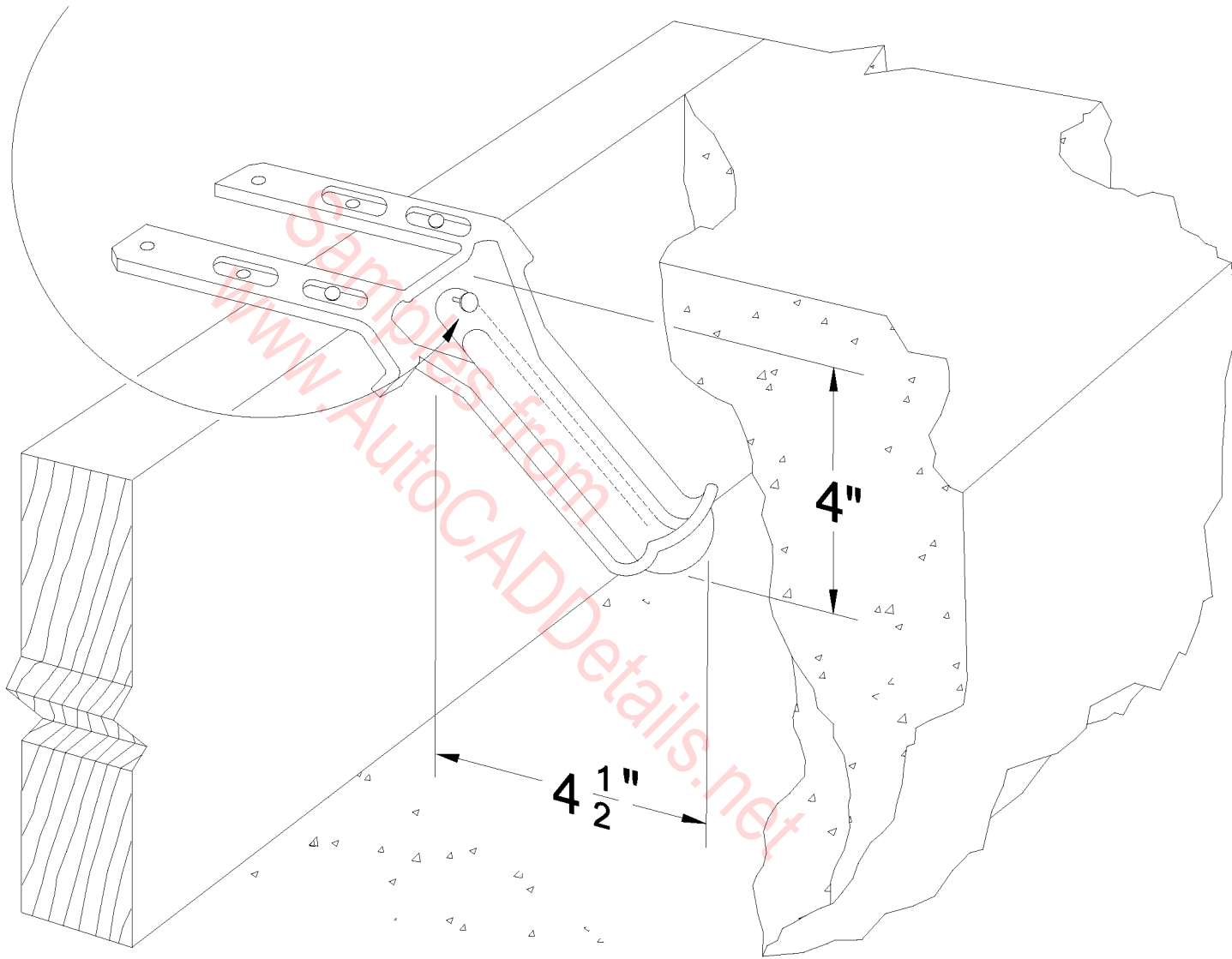

**Mudsill Anchor Singleside - Installation Cut-away**

**Simpson Strong-Tie  
MAS**

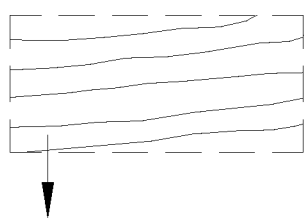

2X4 PLATE

$3 \frac{1}{2}$

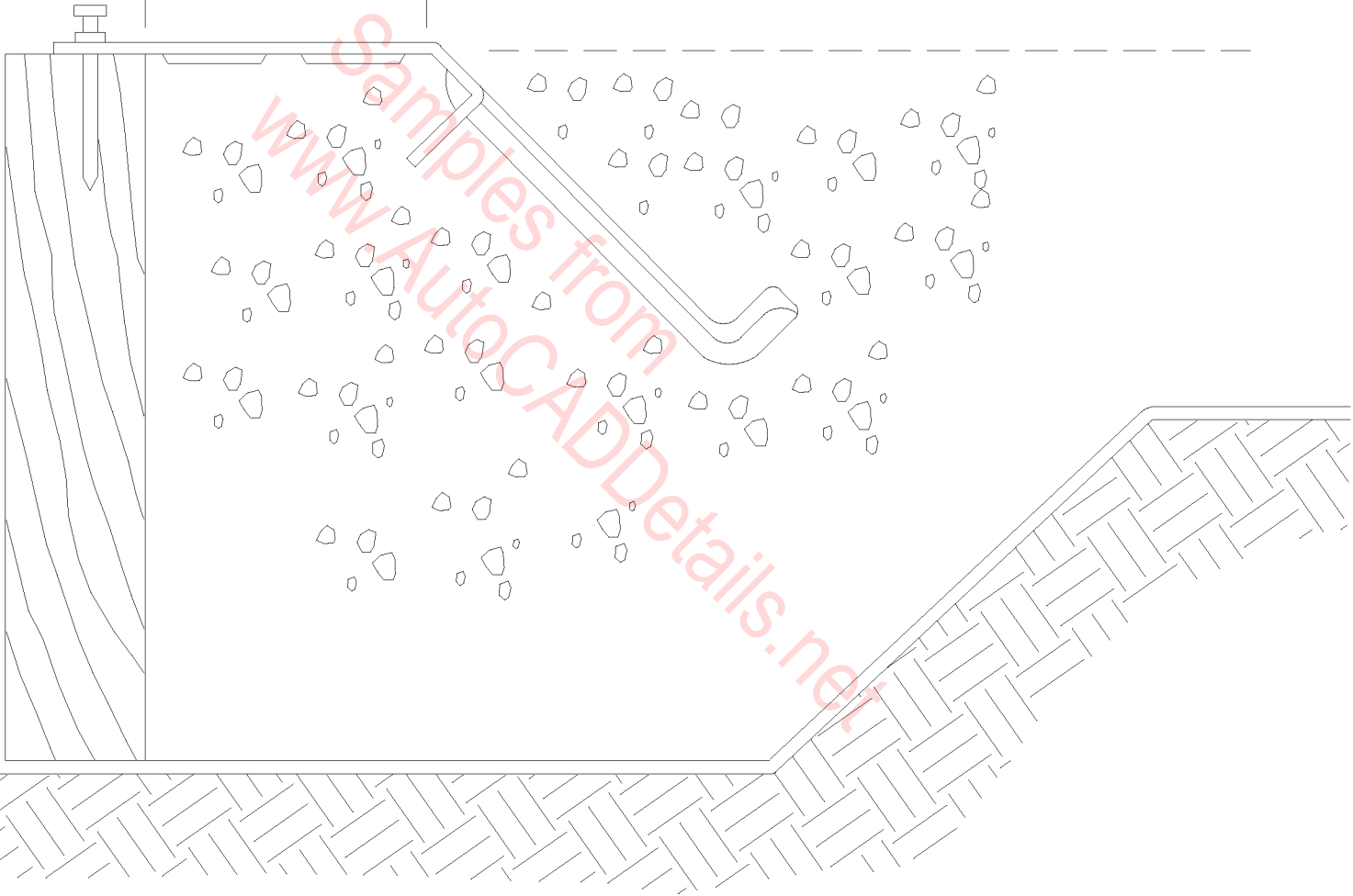

Simpson Strong-Tie  
MAS

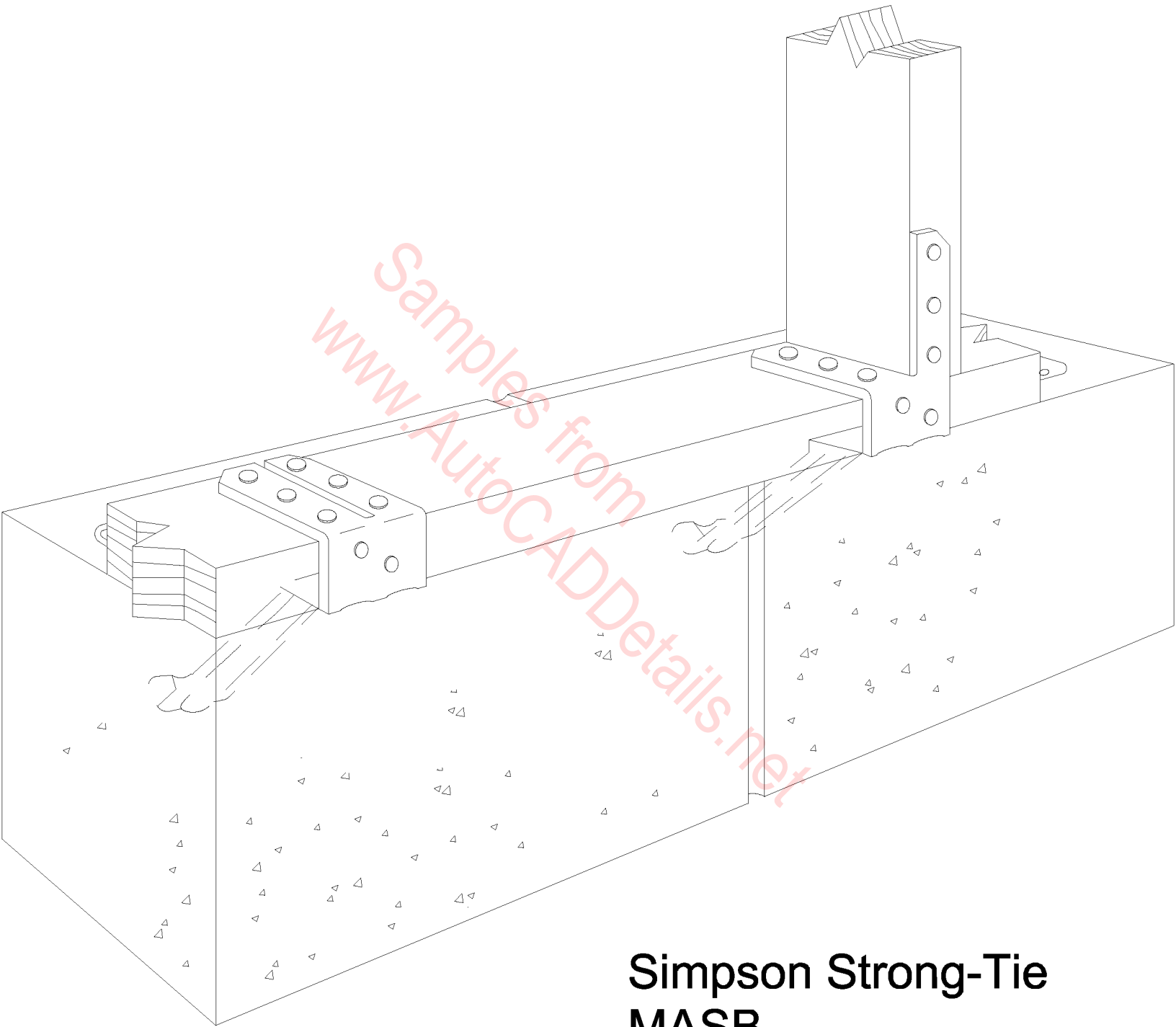

**Simpson Strong-Tie  
MASB**

**Simpson Strong-Tie  
MASB  
Rim Joist Installation**

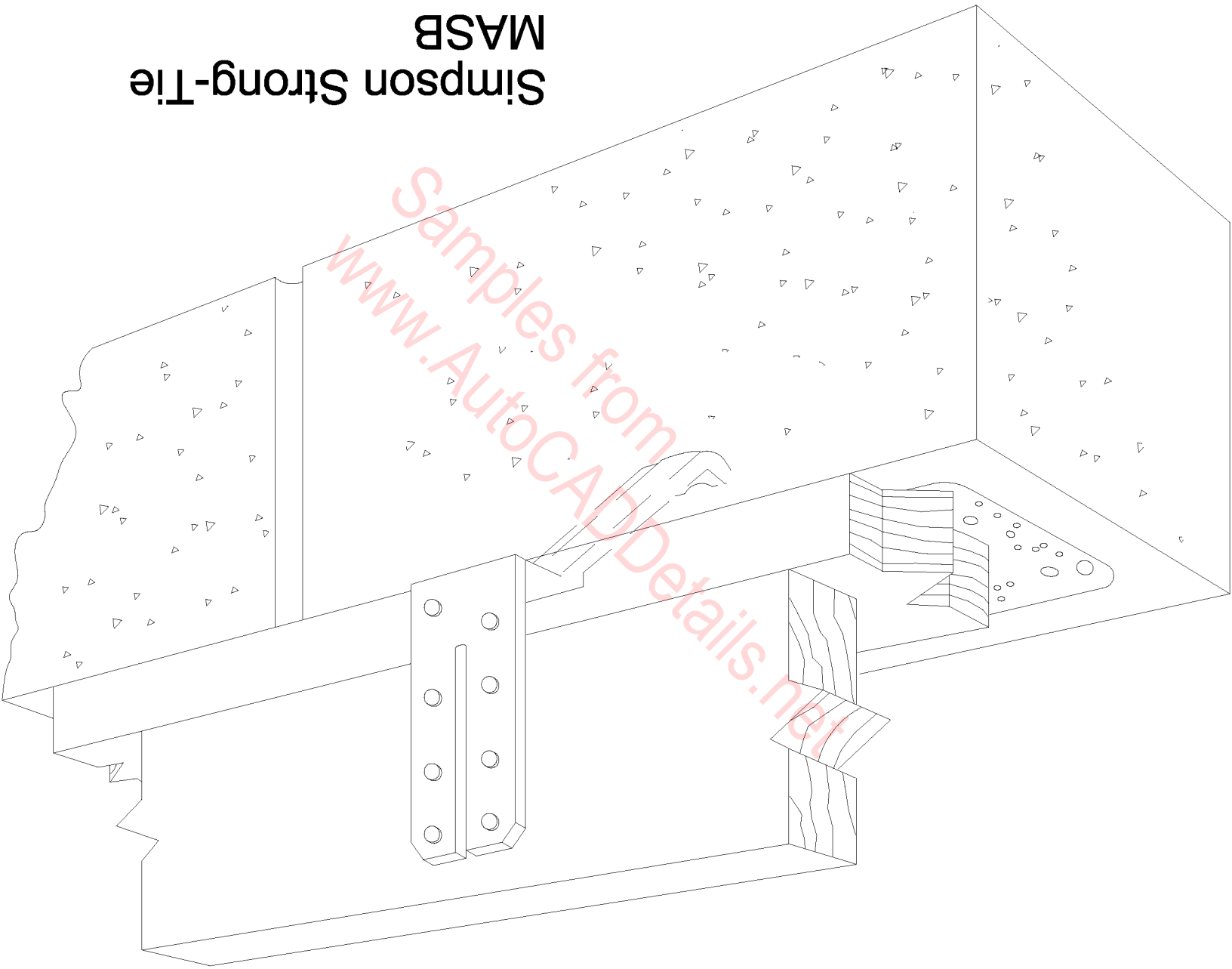



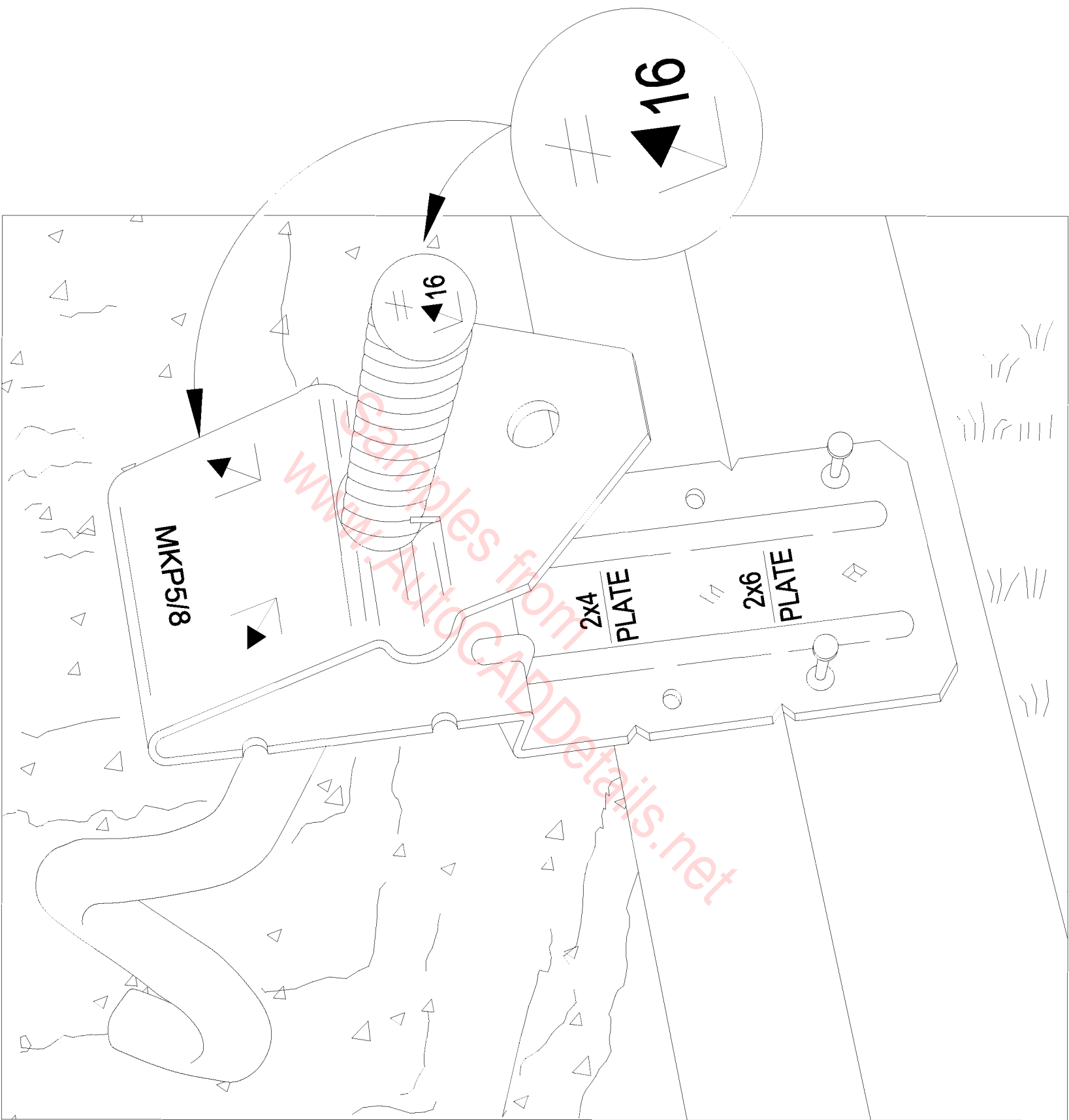

**Simpson Strong-Tie  
MKP 5/8 with SSTB16**

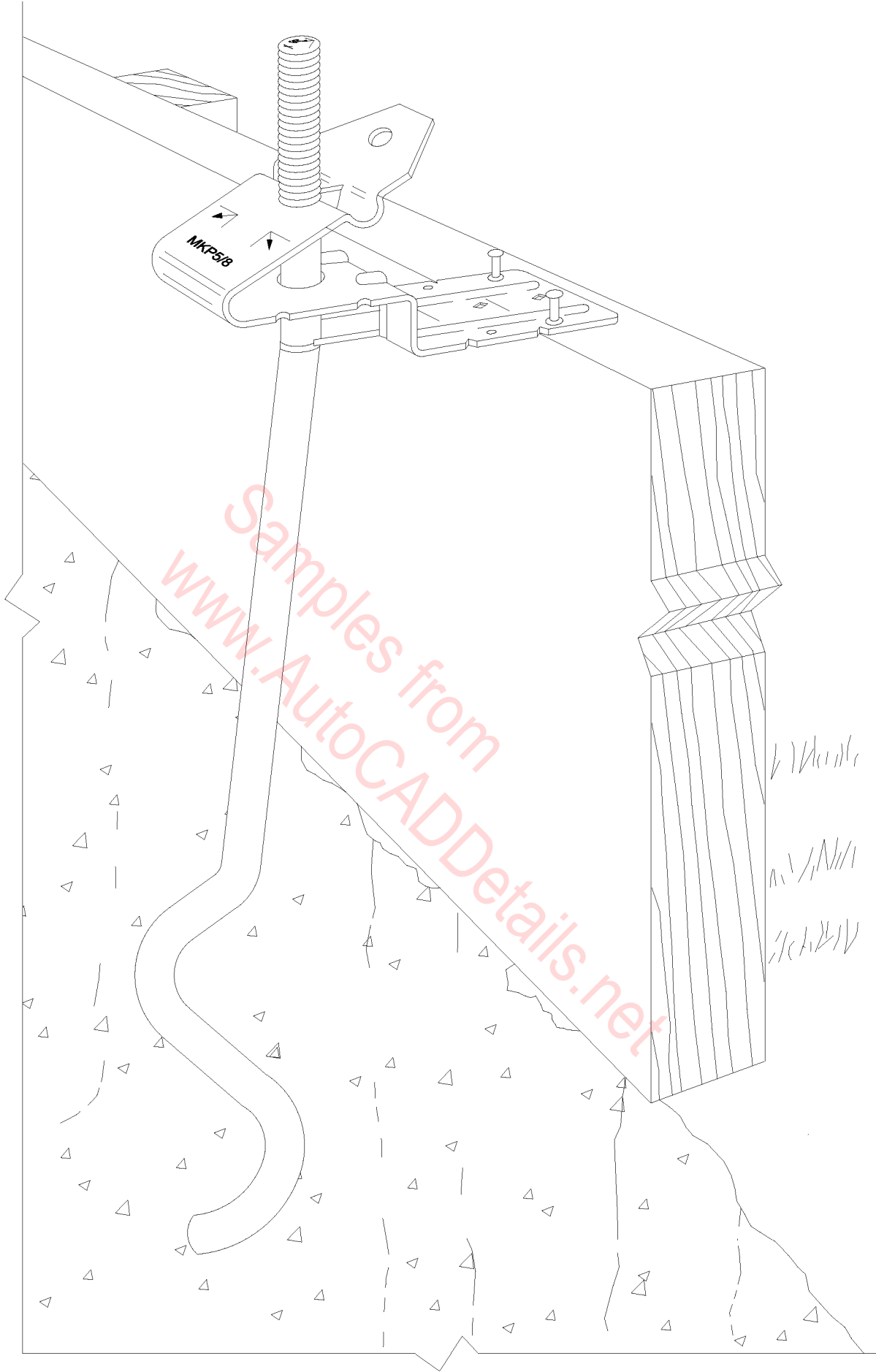

**Simpson Strong-Tie  
MKP 5/8 with SSTB16**

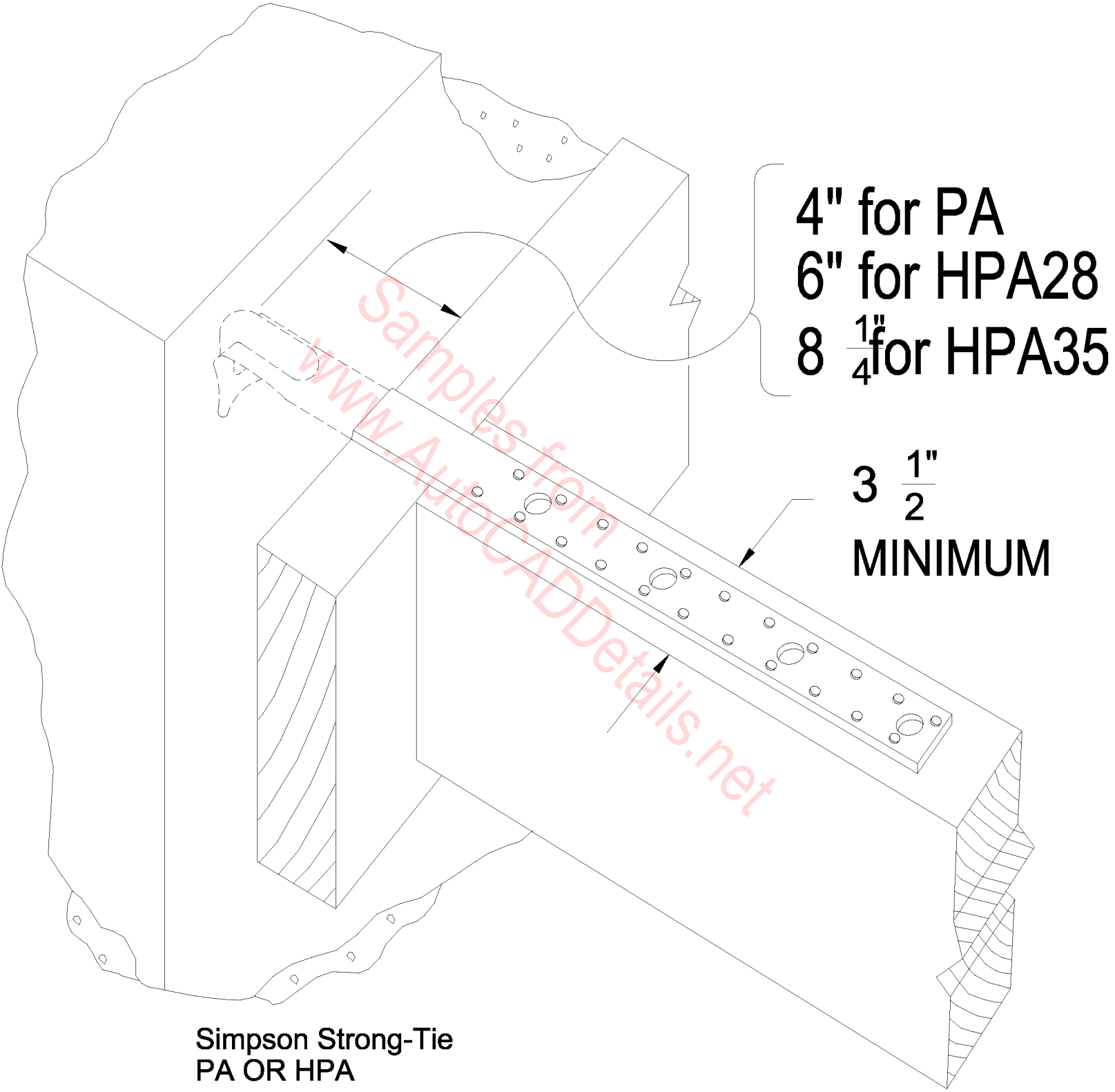

**BEND ADDITIONAL STRAP  
OVER TOP OR  
CUT OFF**

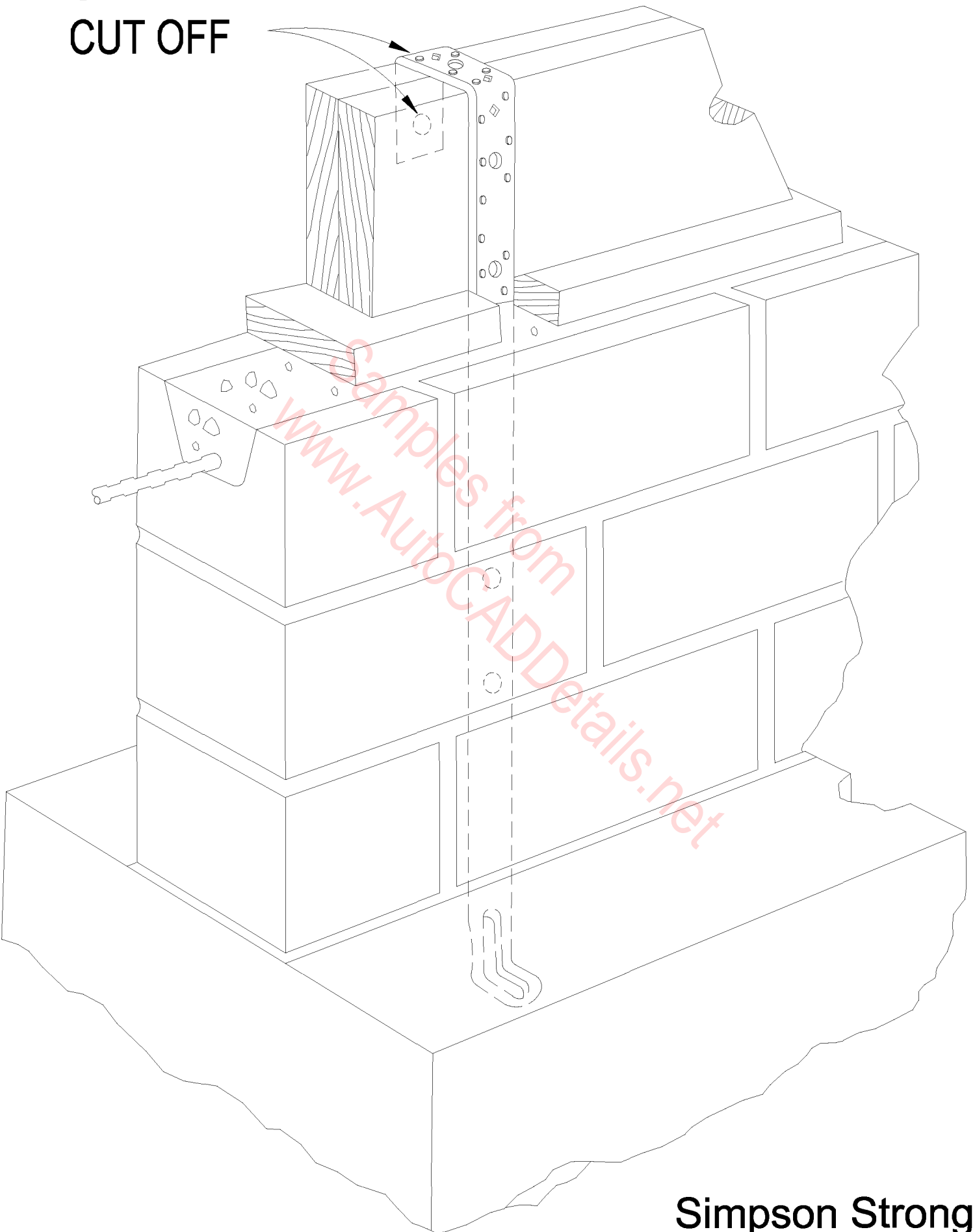

**Simpson Strong-Tie  
PA51**

**BEND UP AFTER  
CONCRETE CURES**

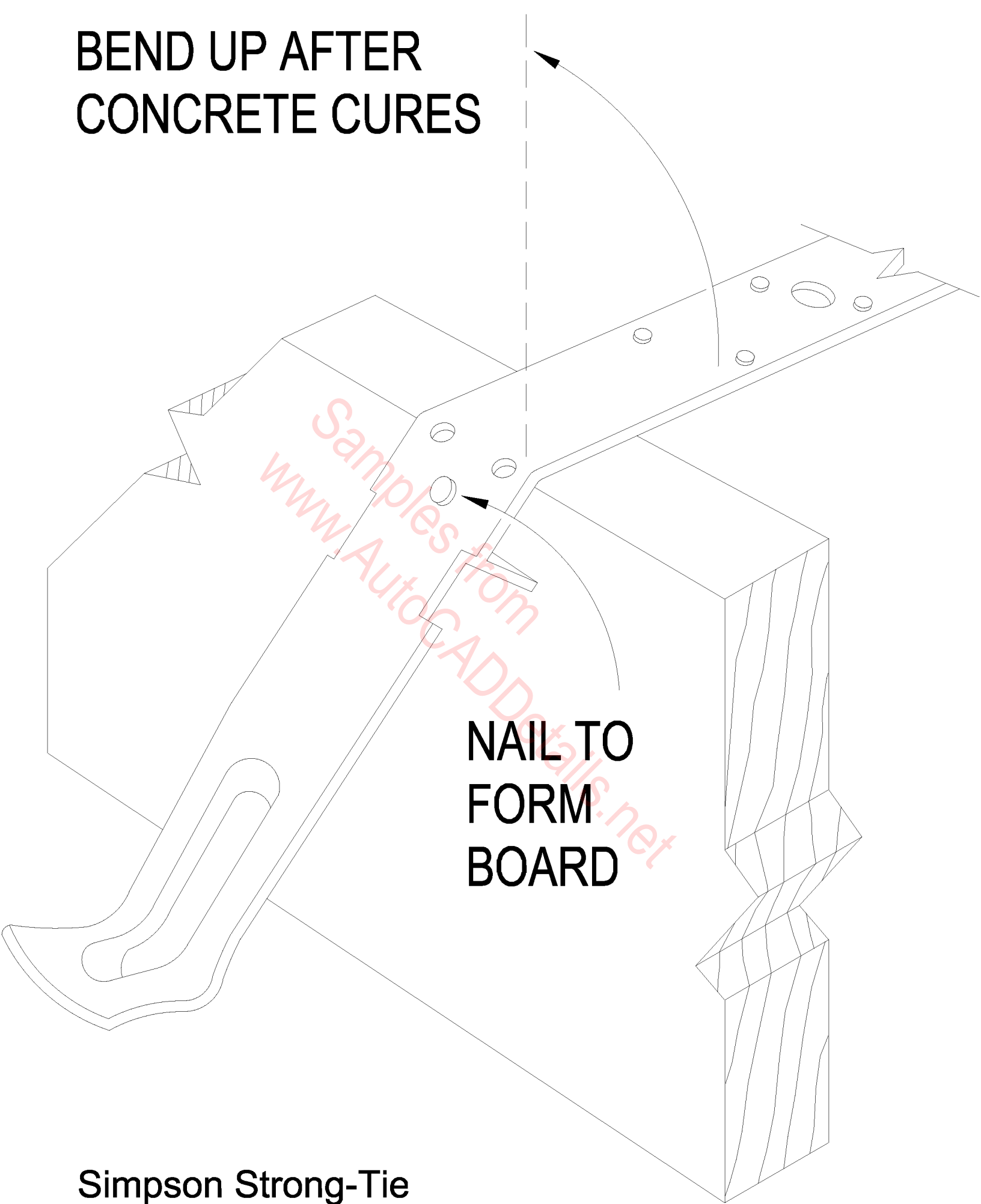

**NAIL TO  
FORM  
BOARD**

**Simpson Strong-Tie  
PAHD42**

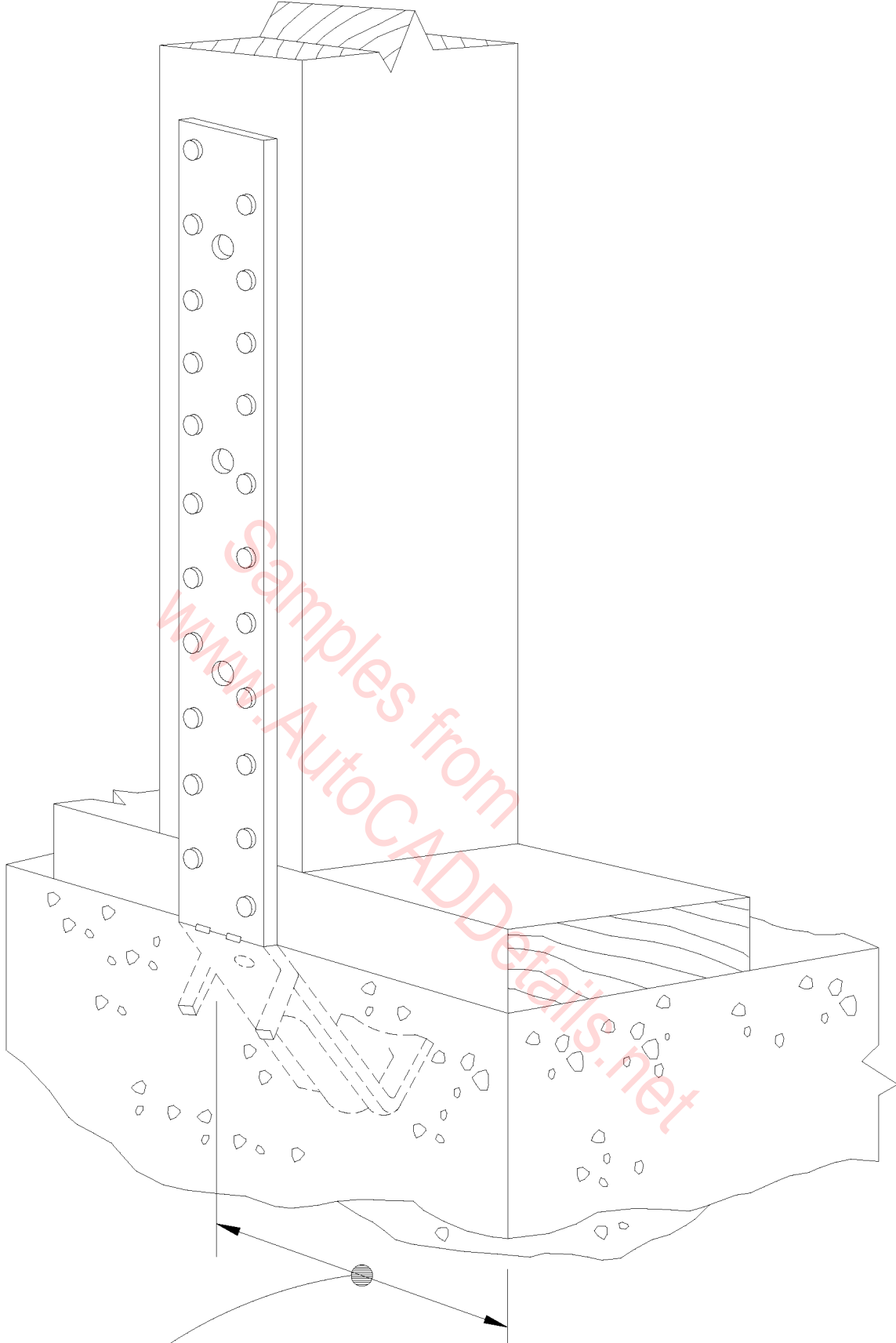

**9" MINIMUM CORNER DISTANCE  
FOR FULL VALUES.**

**Simpson Strong-Tie  
PAHD42**

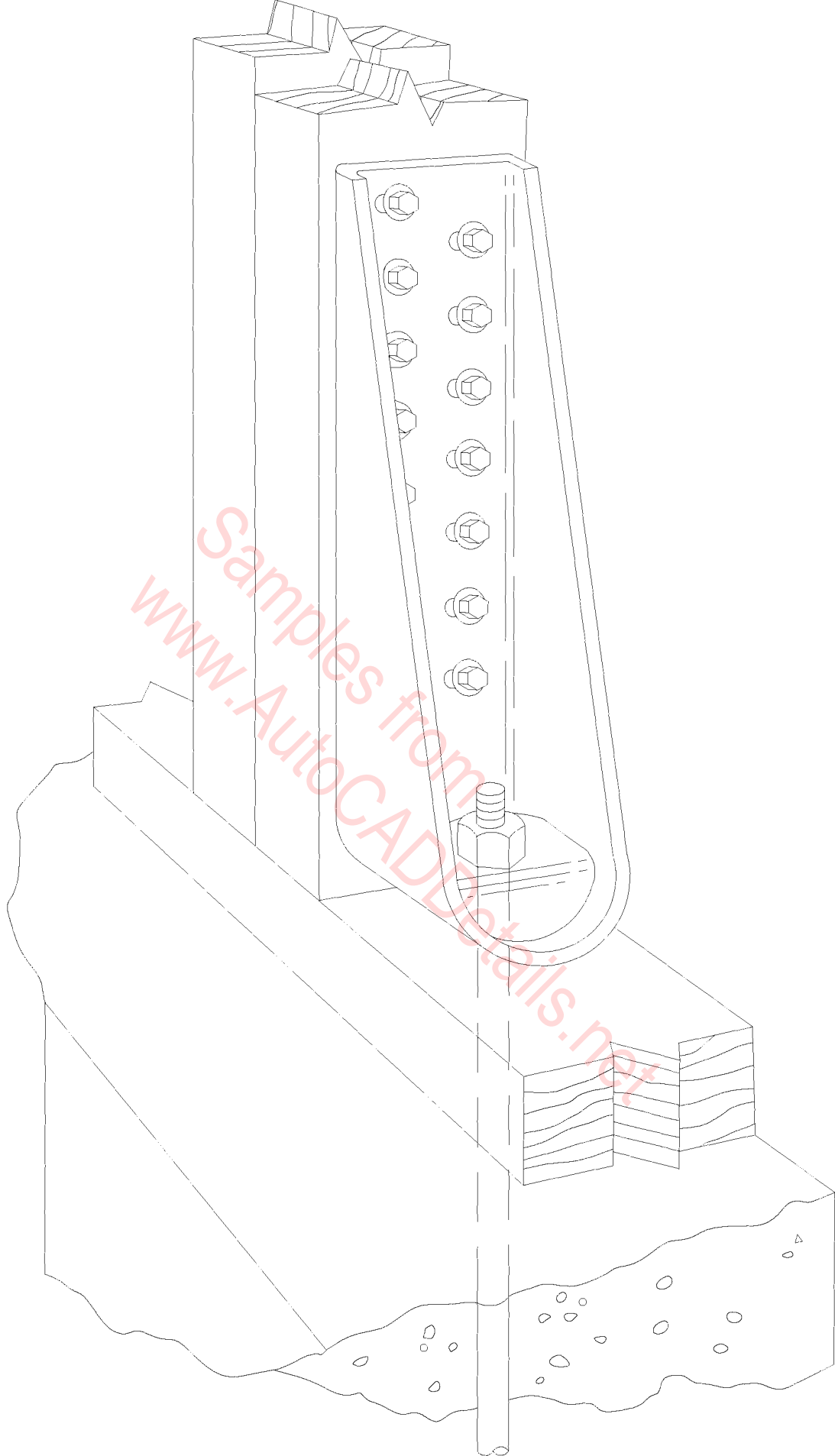

**Simpson Strong-Tie  
PHD**

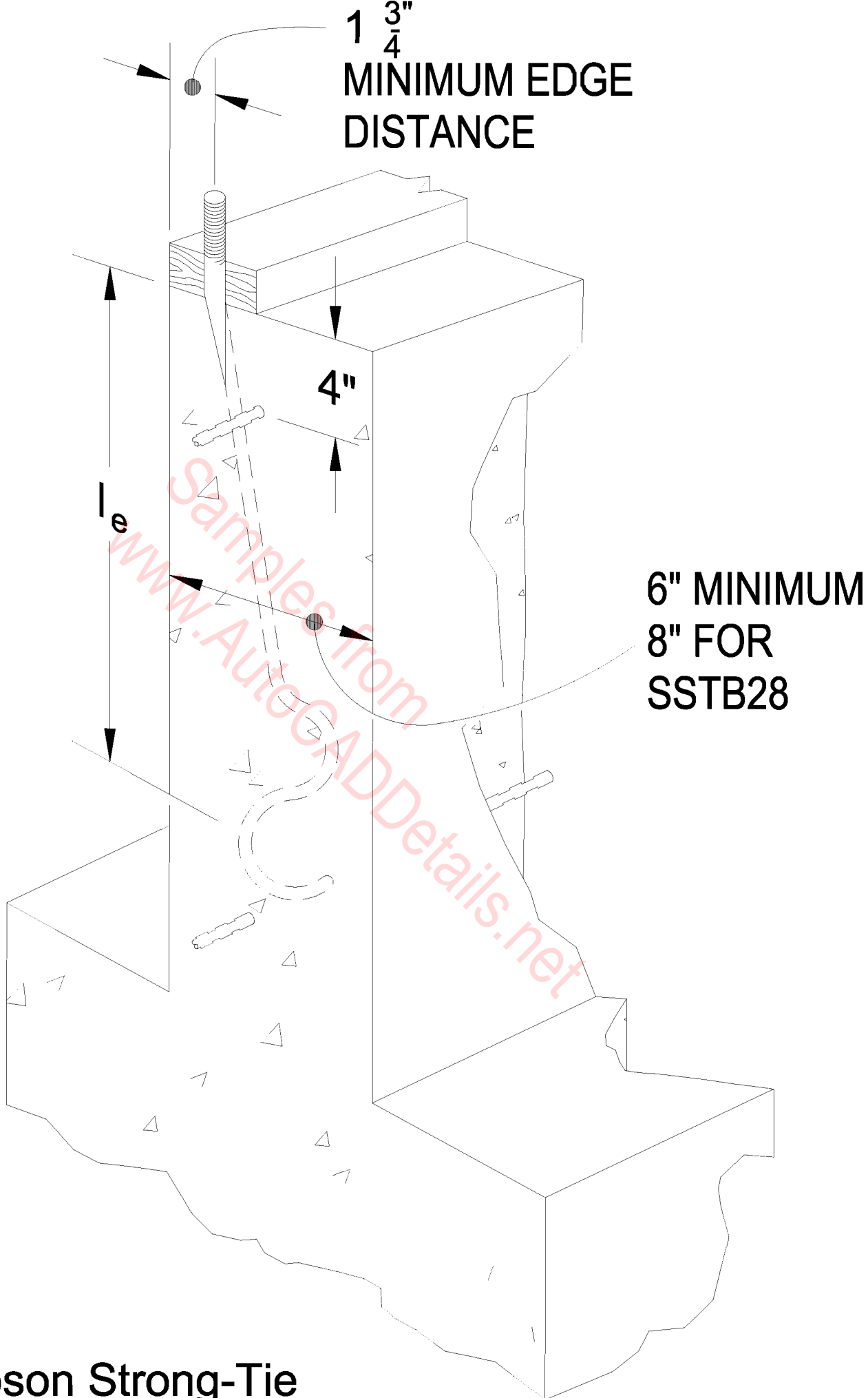

1 <sup>3</sup>/<sub>4</sub>"  
MINIMUM EDGE  
DISTANCE

6" MINIMUM  
8" FOR  
SSTB28

Simpson Strong-Tie  
SSTB



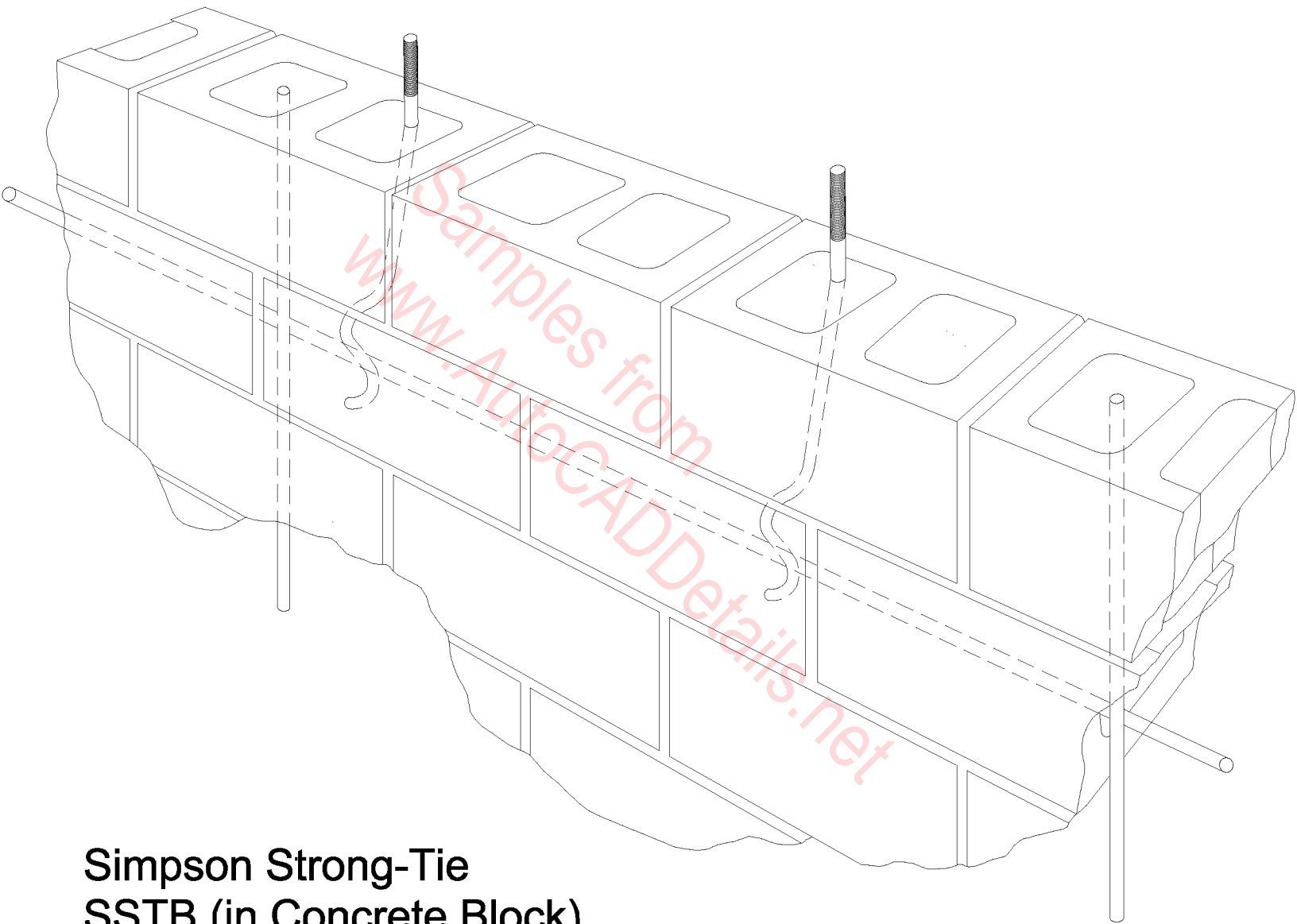

**Simpson Strong-Tie  
SSTB (in Concrete Block)**

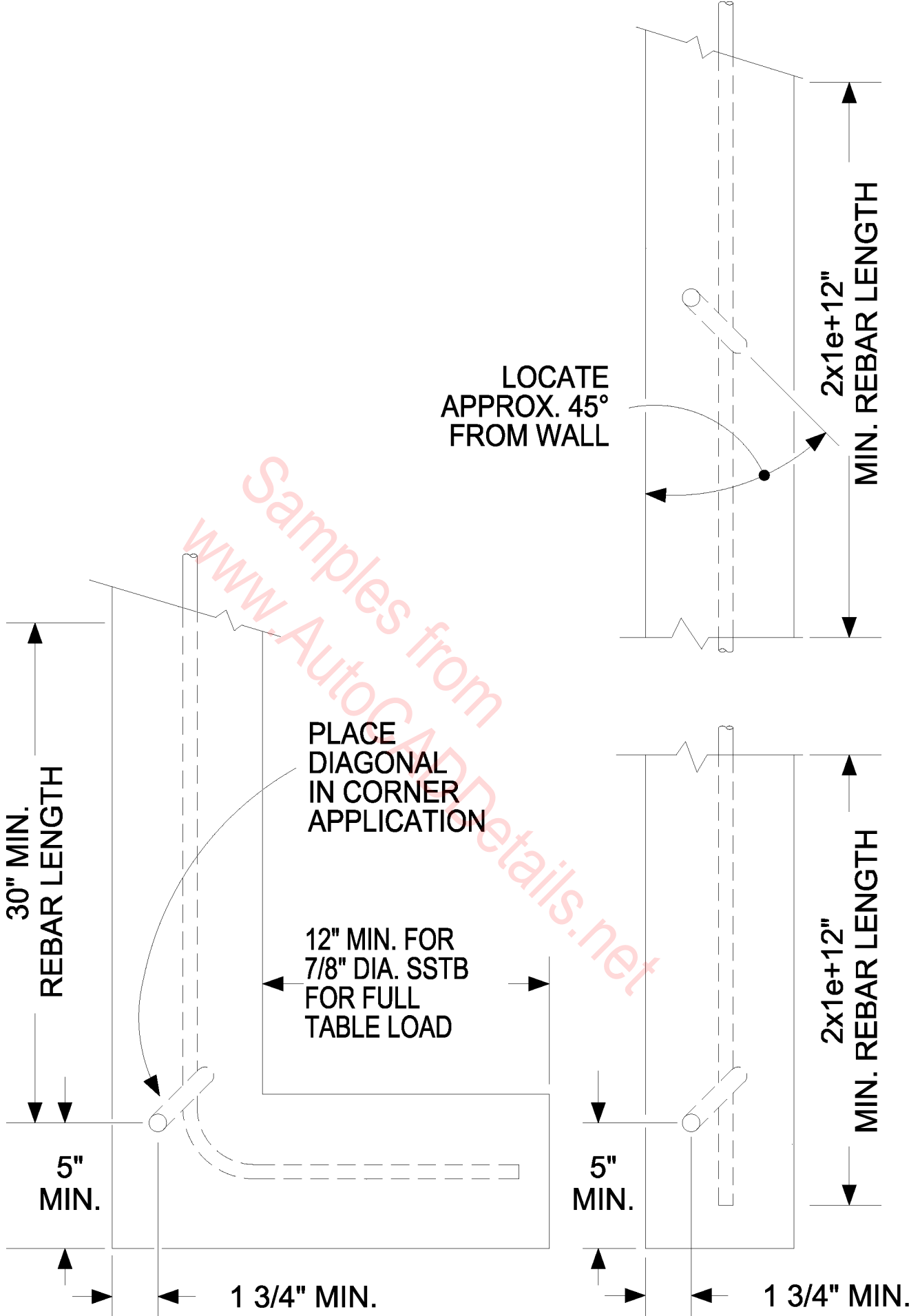

Simpson Strong-Tie  
 SSTB (in plan view)

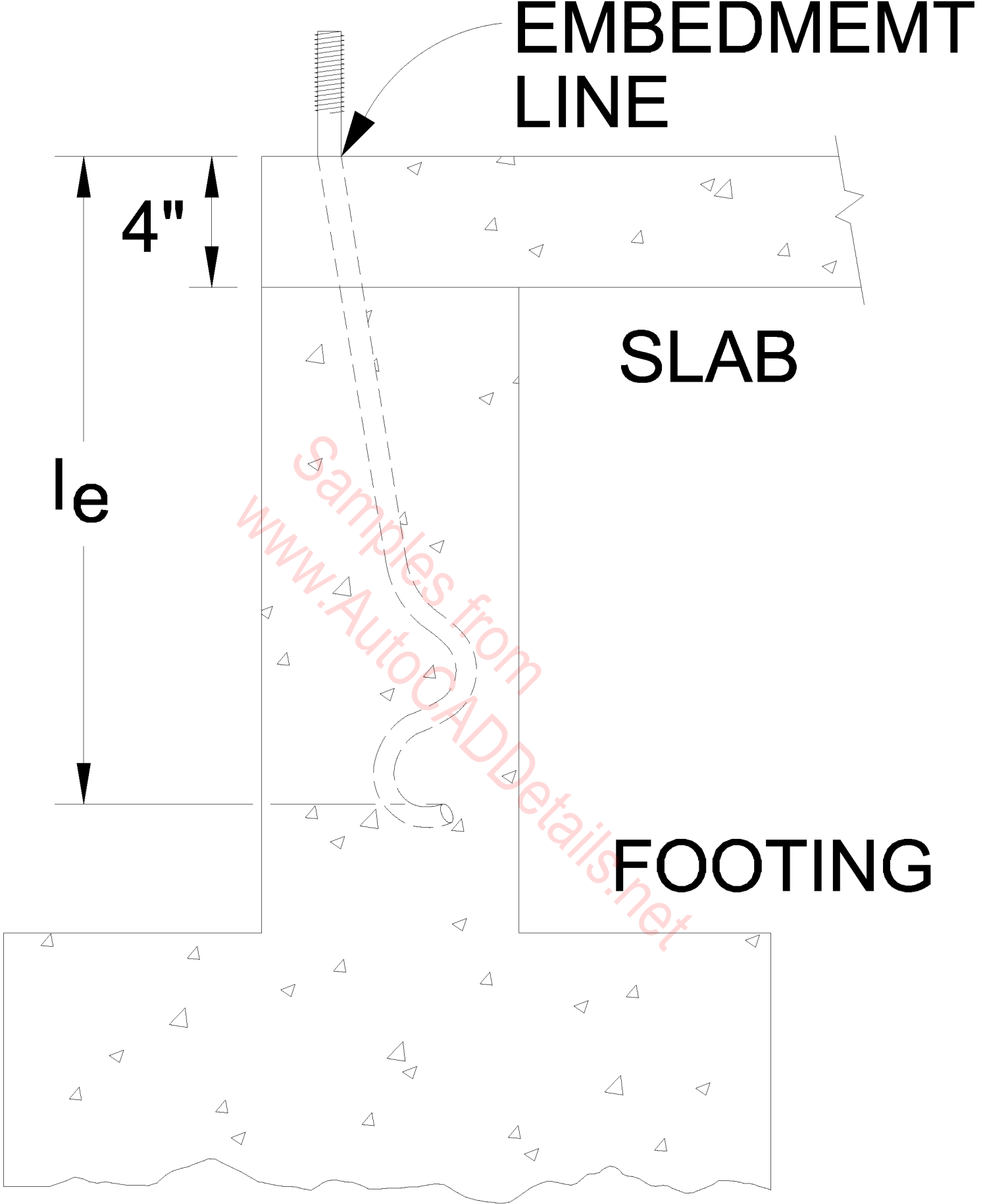

**Simpson Strong-Tie  
SSTB**

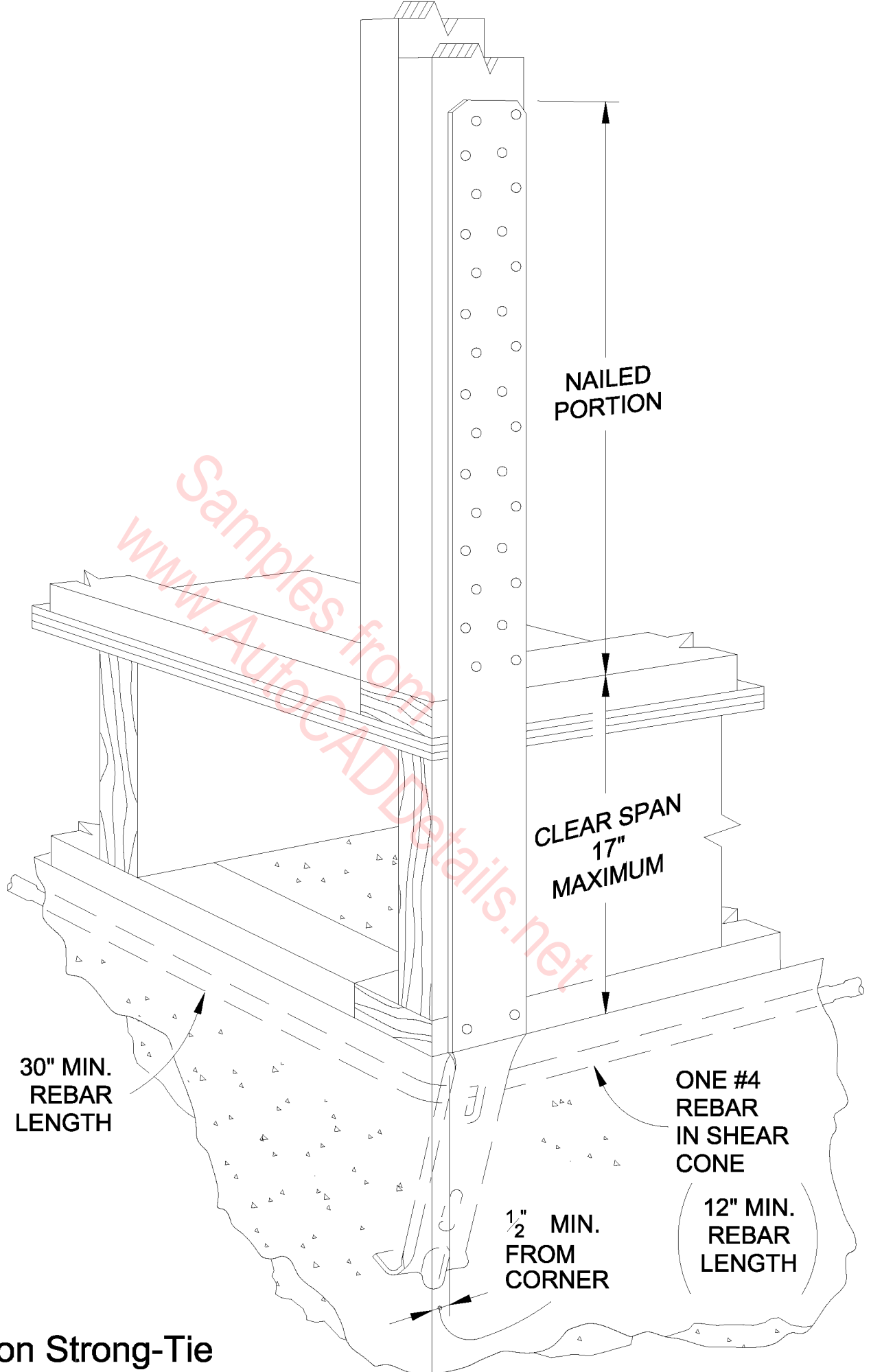

Simpson Strong-Tie  
STHD14RJ  
Rim Joist Installation

**2x**  
**EMBEDMENT**  
**LENGTH**  
**+12" MIN.**  
**REBAR**  
**LENGTH**

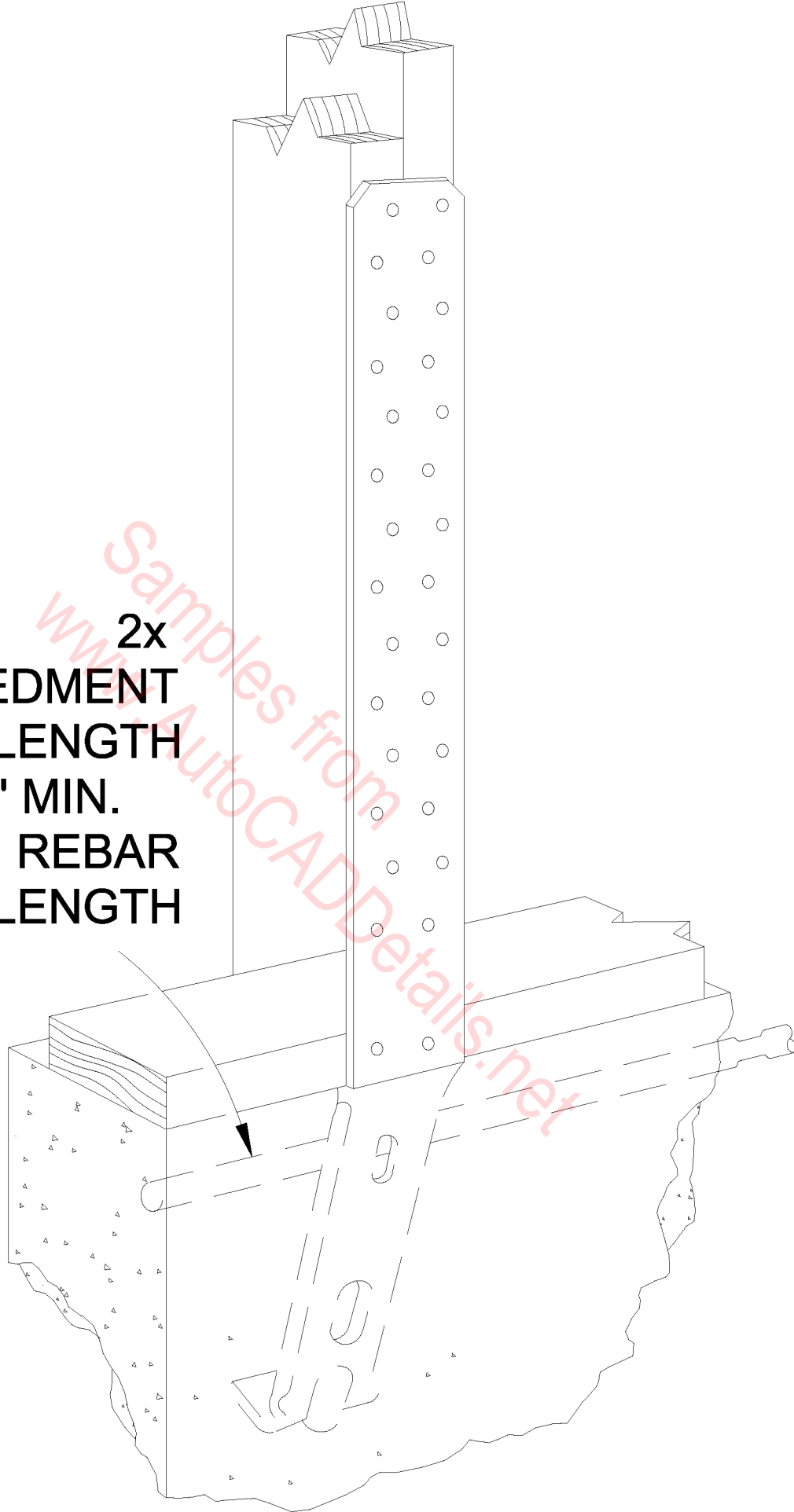

**Simpson Strong-Tie**  
**STHD Edge Installation**

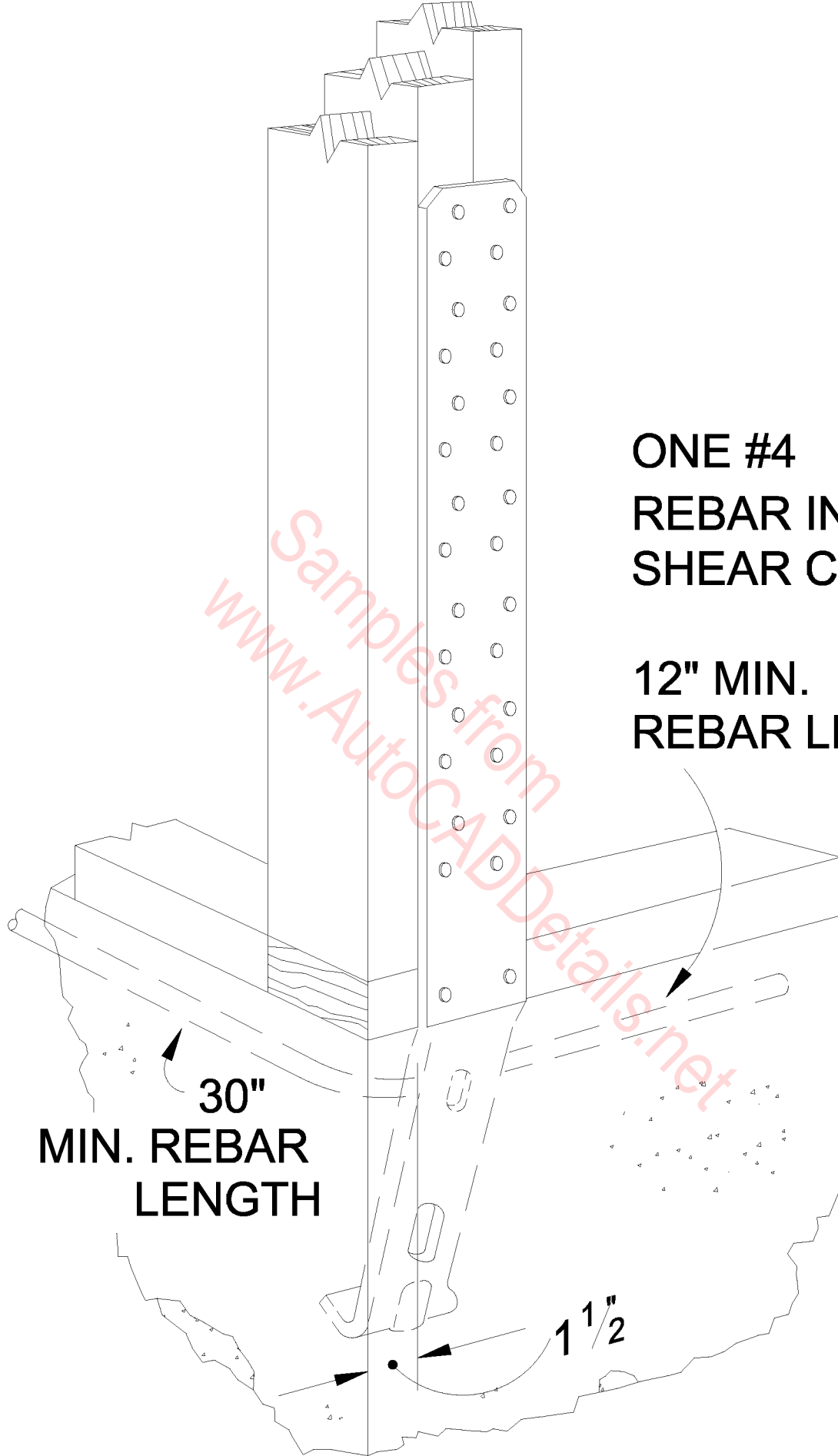

Simpson Strong-Tie  
STHD Corner Installation  
on Triple Studs

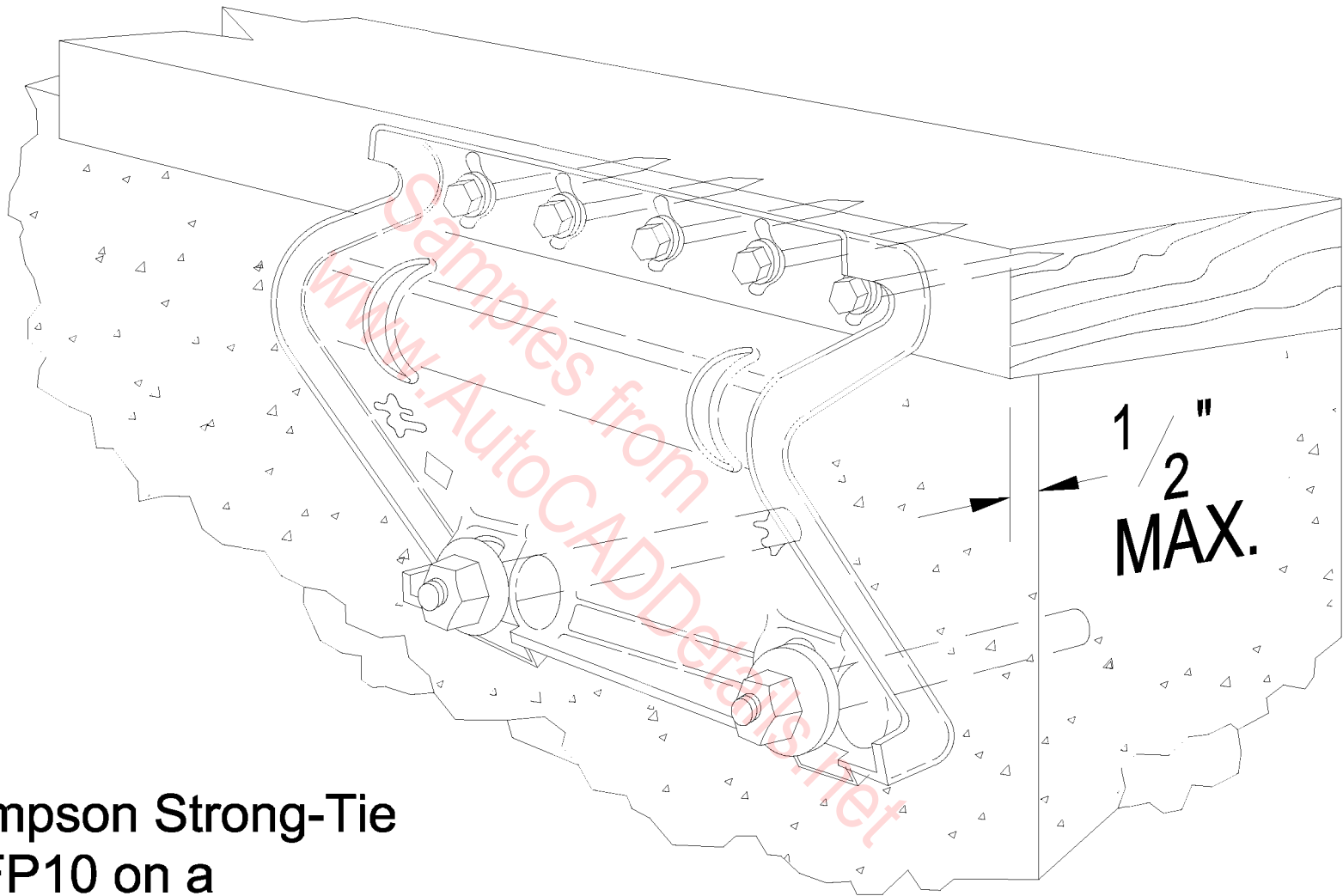

1/2"  
MAX.

**Simpson Strong-Tie  
UFP10 on a  
Straight Foundation with  
Offset Mudsill**

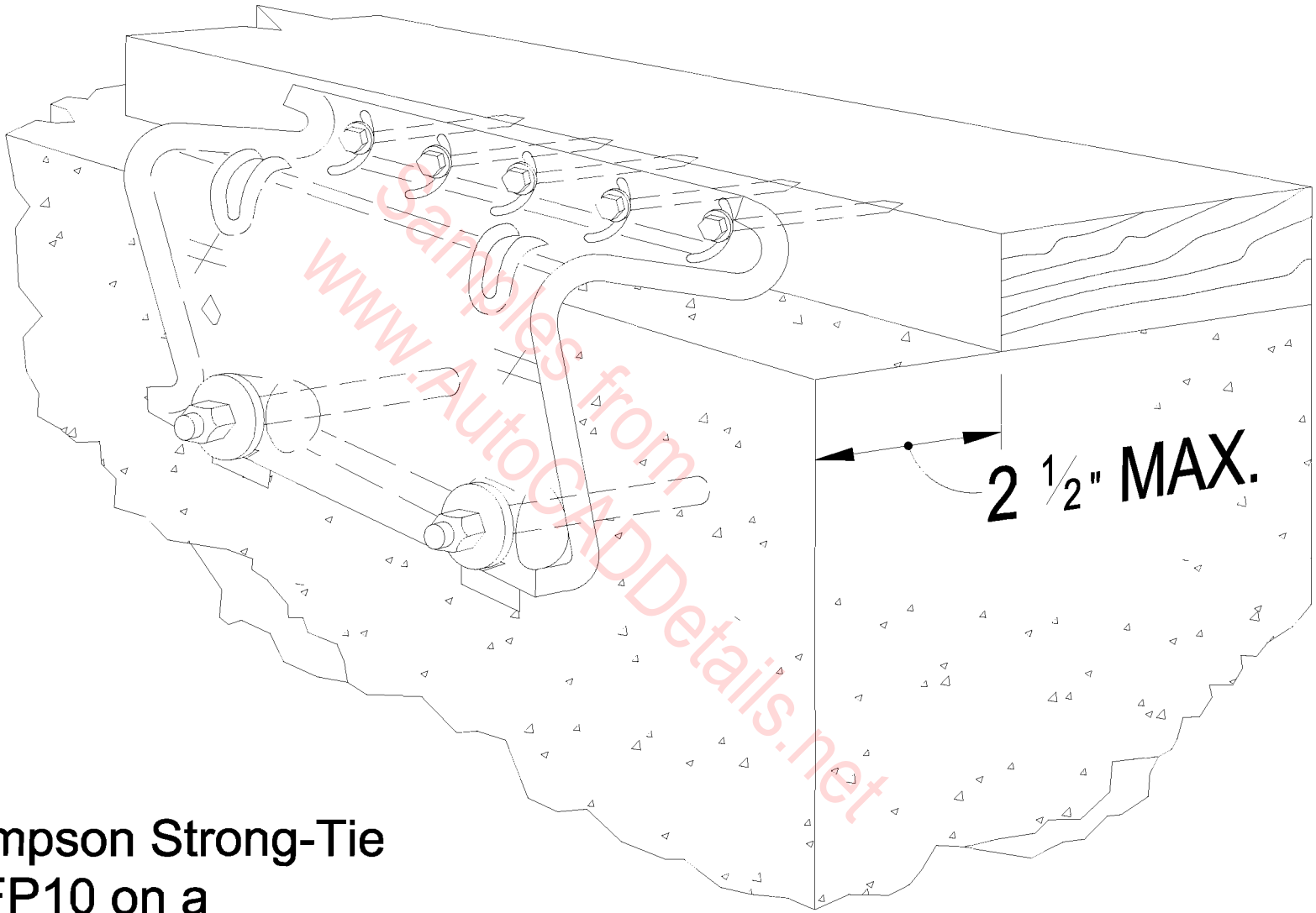

**Simpson Strong-Tie  
UFP10 on a  
Straight Foundation**



# Simpson Strong-Tie UFP10 on Trapezoid Foundation

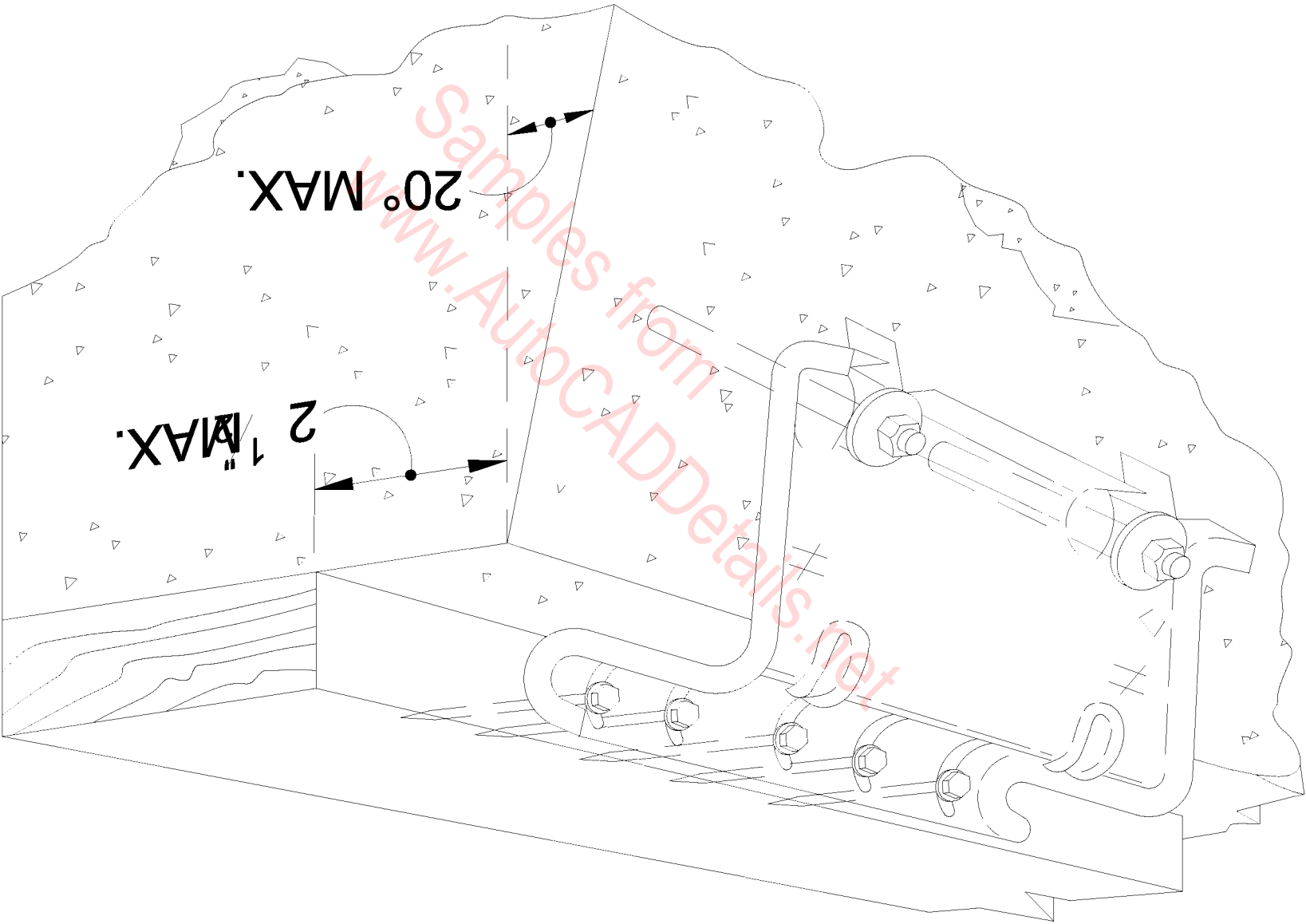

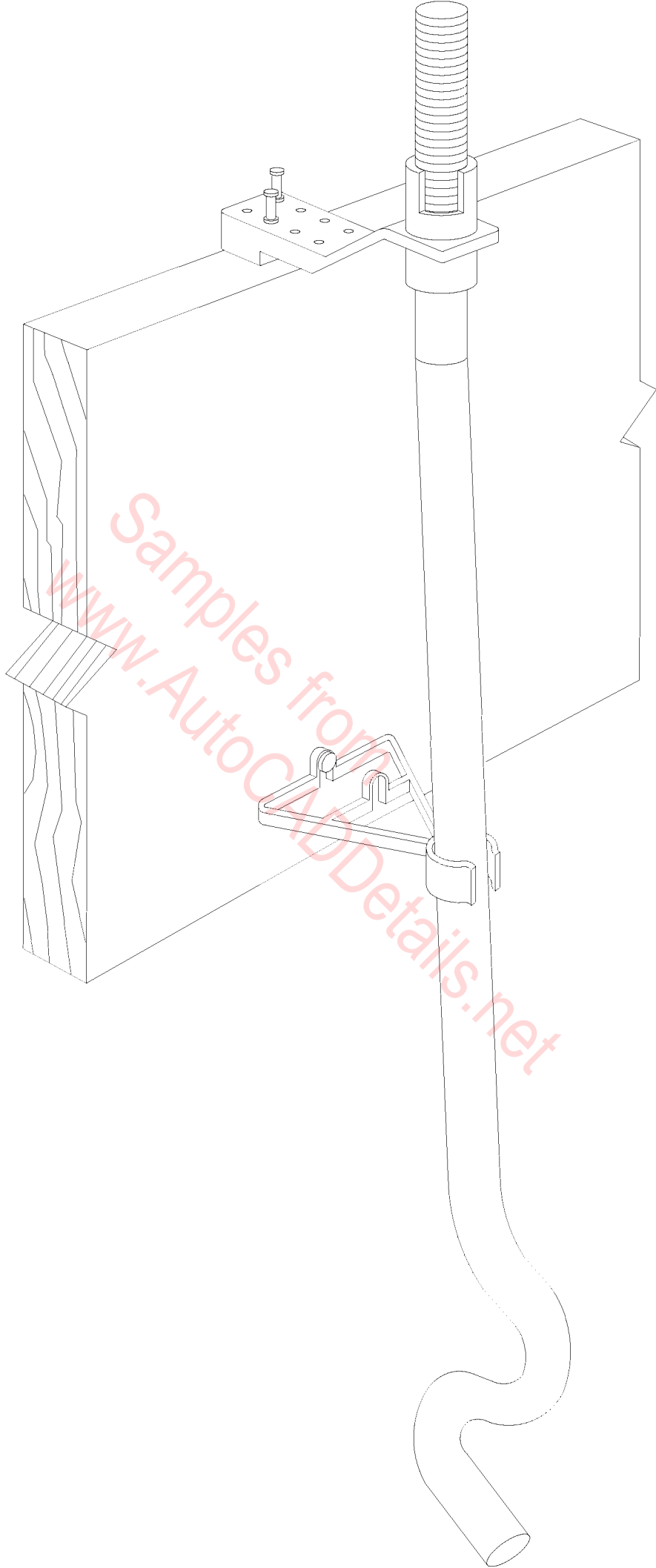

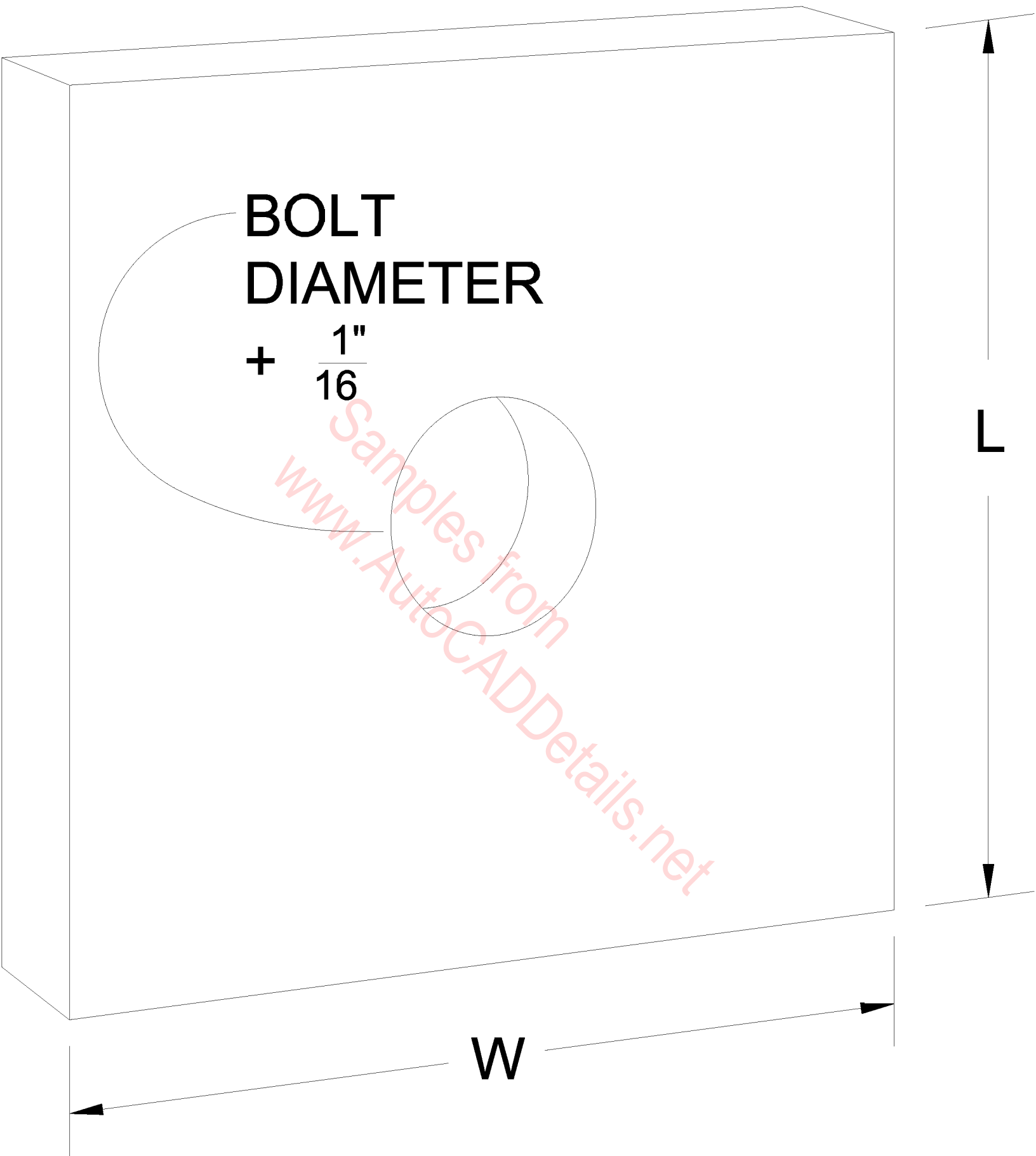

**BOLT  
DIAMETER**

$$+ \frac{1''}{16}$$

Samples from  
[www.AutocADDetails.net](http://www.AutocADDetails.net)

**W**

**L**

**Simpson Strong-Tie  
BP**

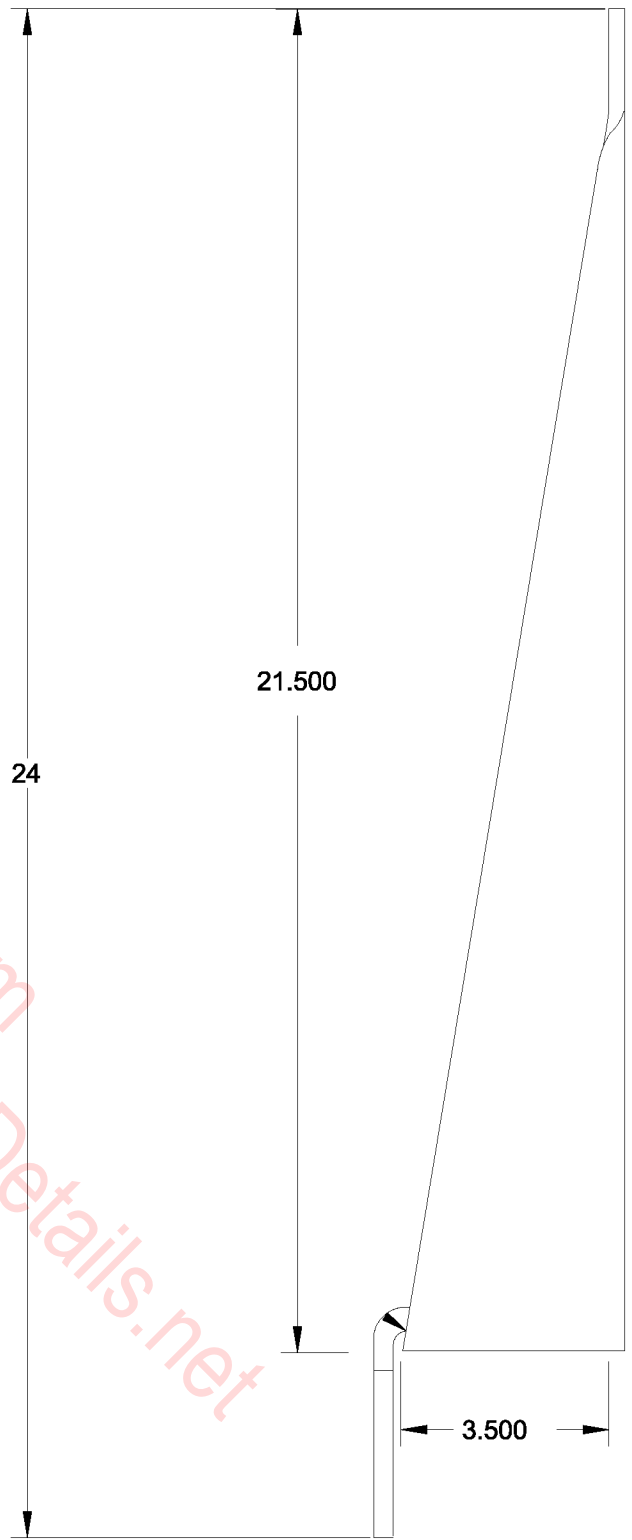
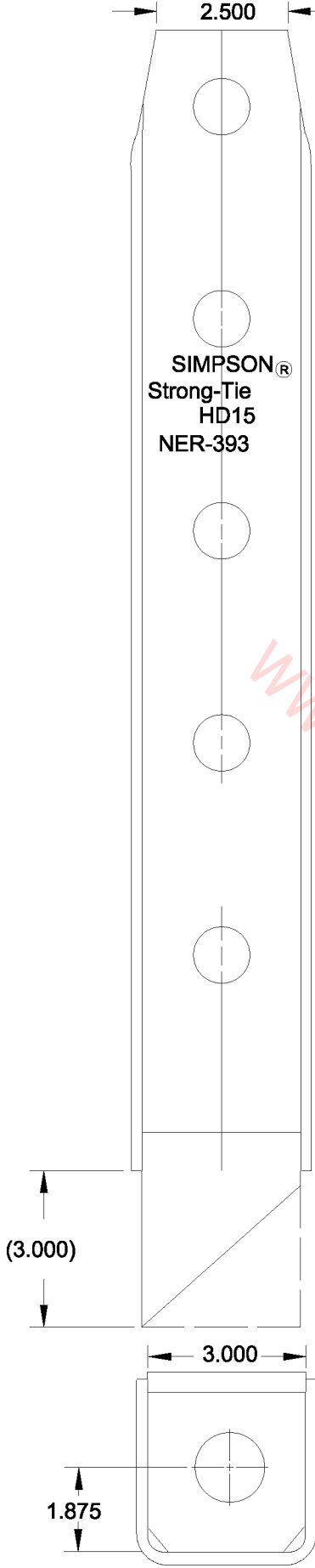

SIMPSON®  
Strong-Tie  
HD15

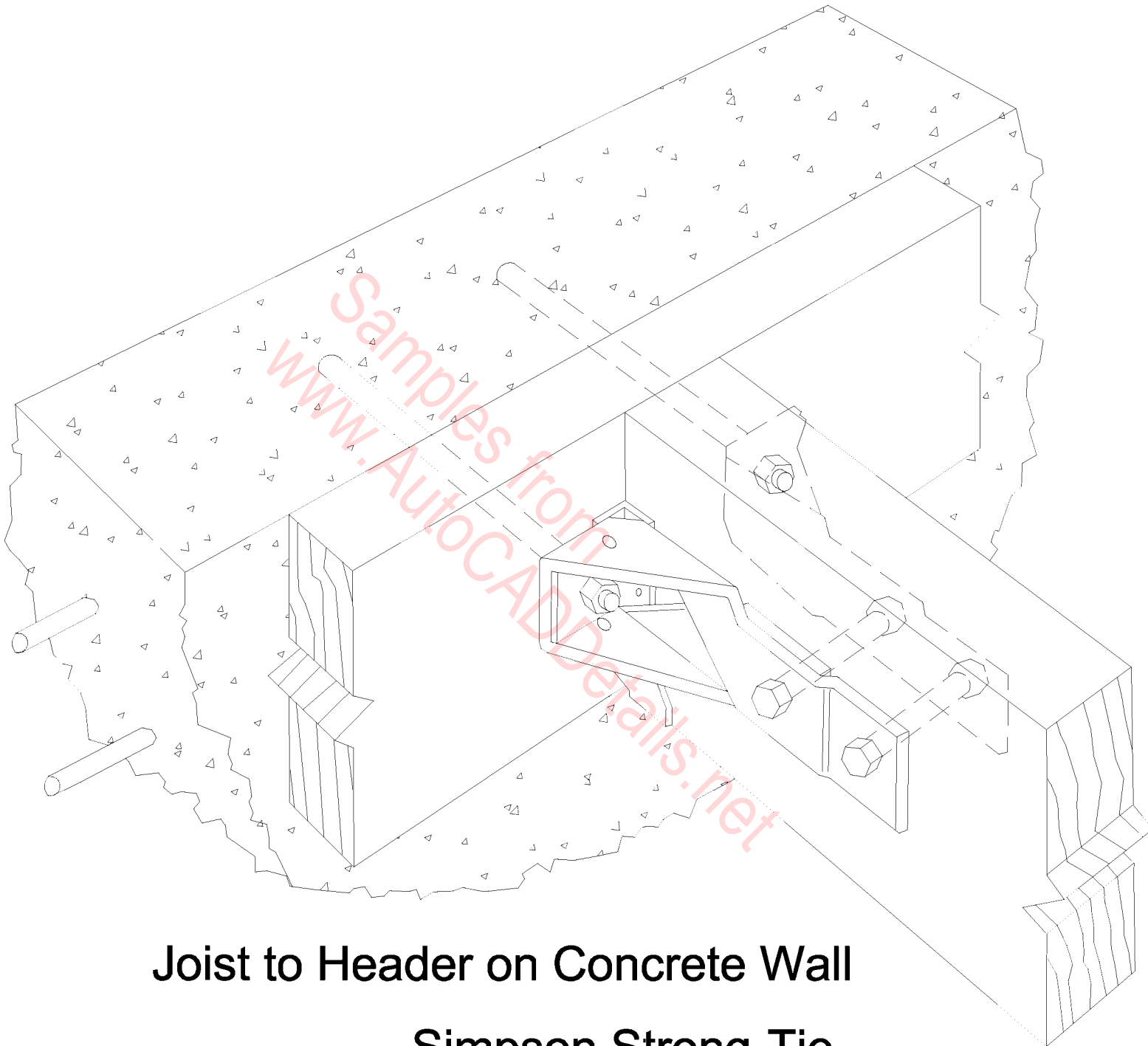

**Joist to Header on Concrete Wall**

**Simpson Strong-Tie  
HD5A with HU48**

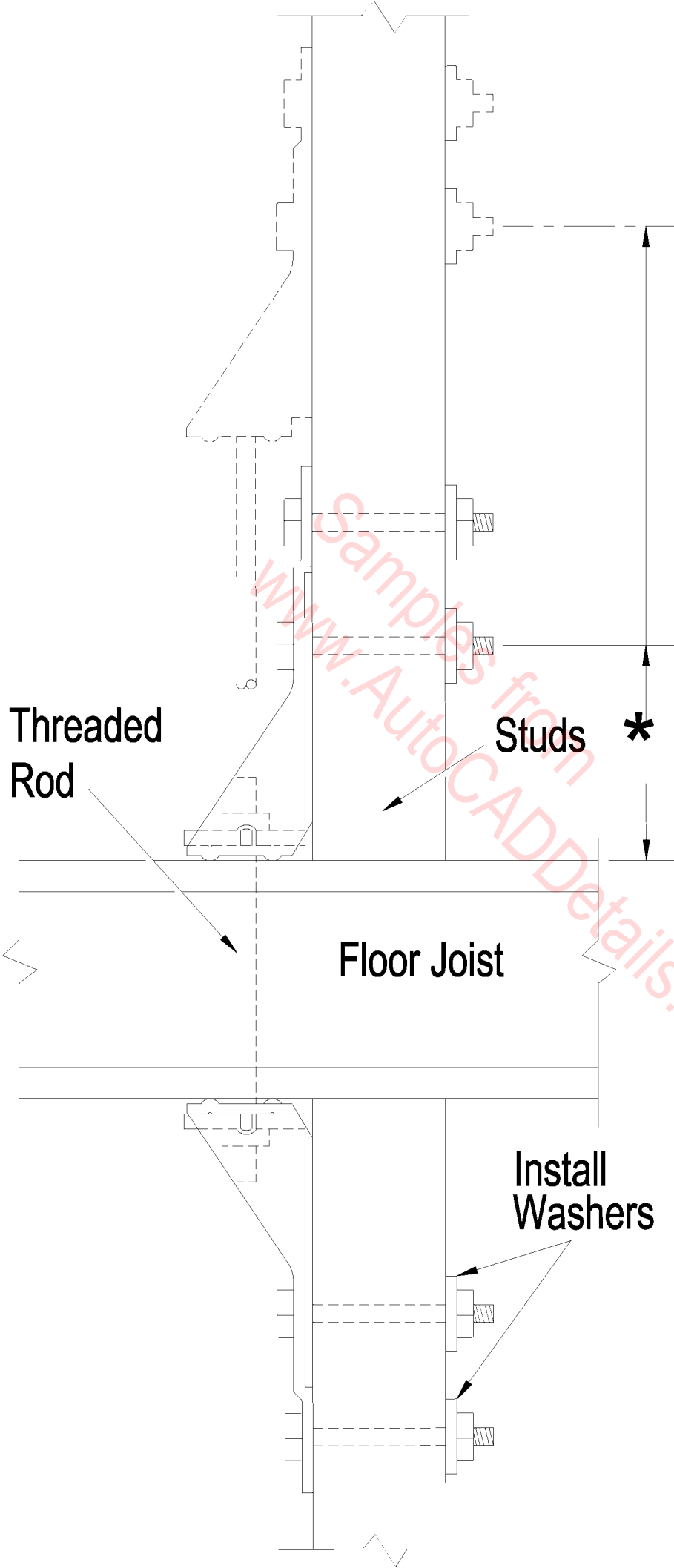

Threaded Rod

Studs \*

Floor Joist

Install Washers

\* Minimum of seven bolt diameters to achieve table loads. This distance is designed into holddown. Distance may be increased without affecting load capacity, provided the anchor nut is not over-torqued, which could split the stud.

Simpson Strong-Tie  
HD5A

Samples from  
www.AutoCADDetails.net

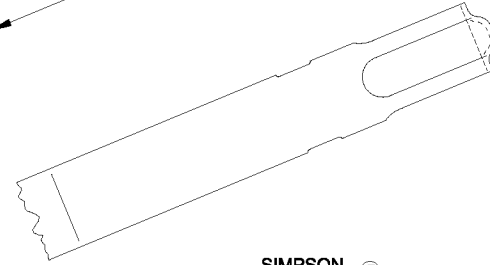
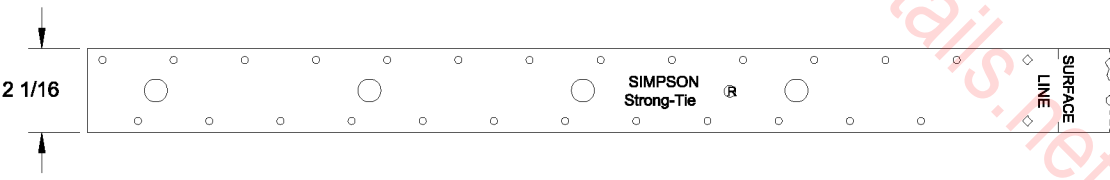
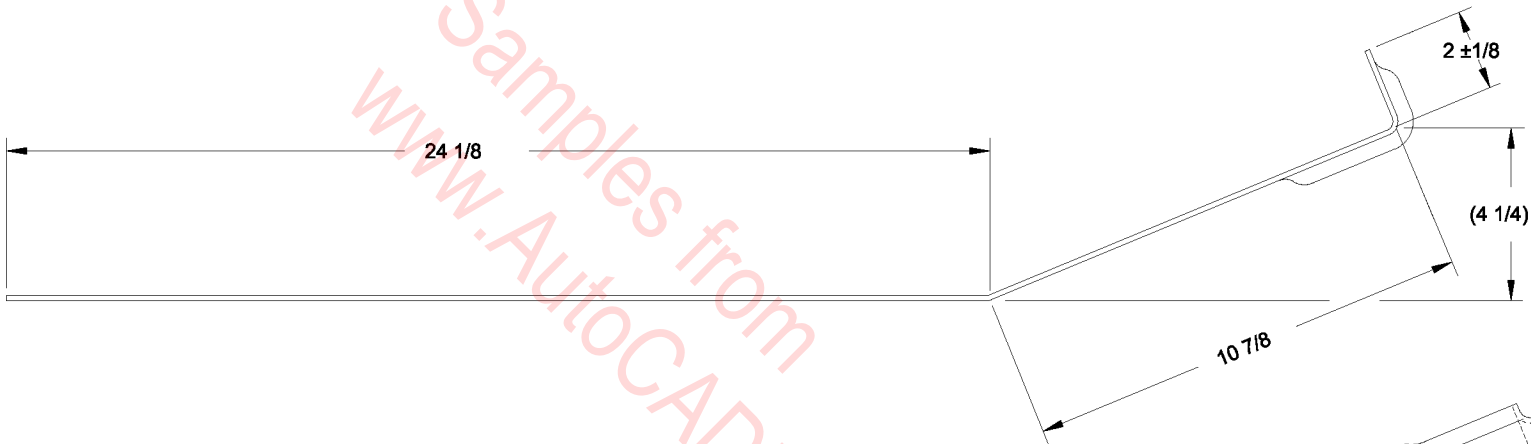

SIMPSON Strong-Tie ®  
HPAHD22

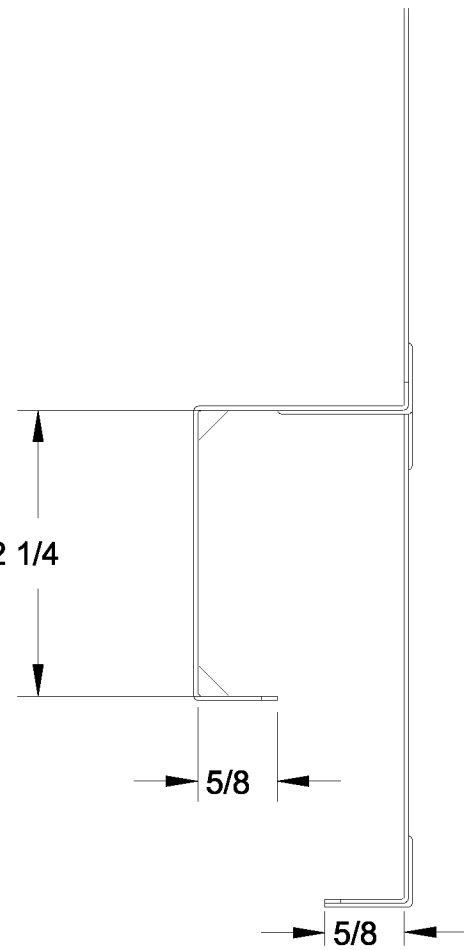
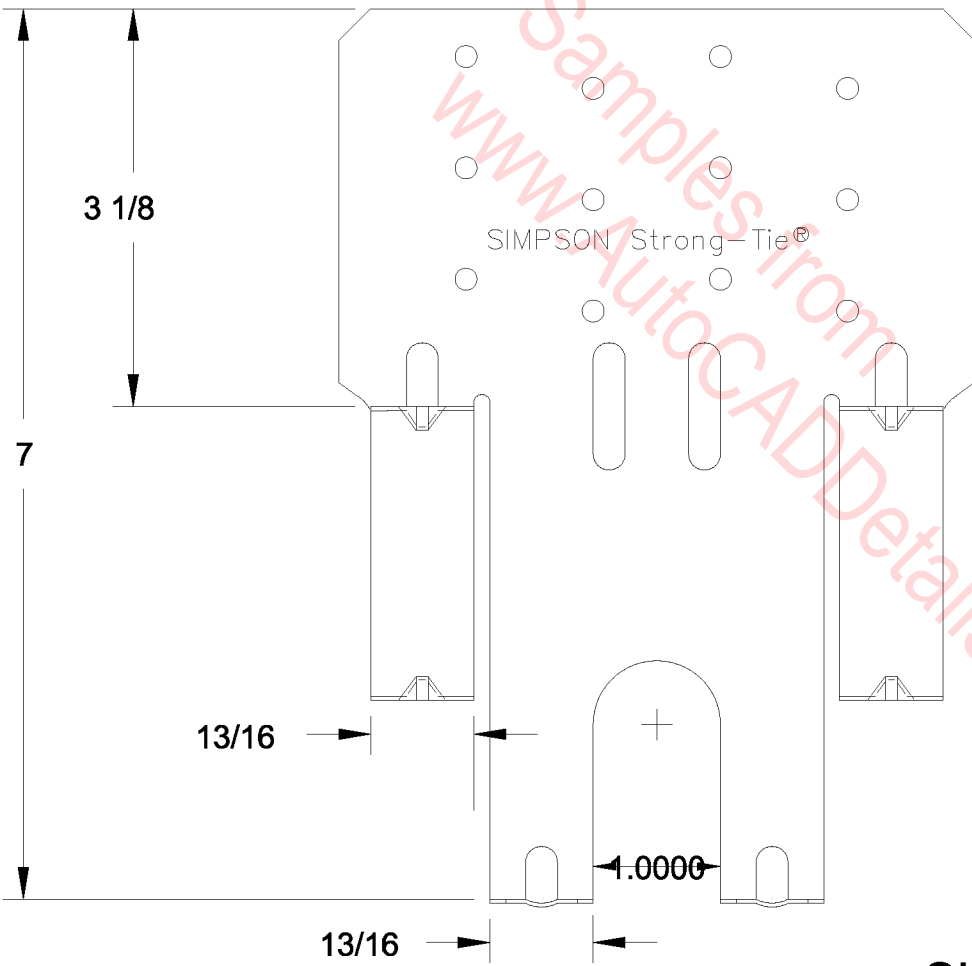
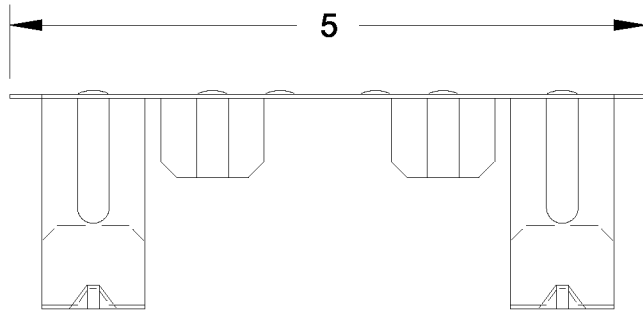

Samples from  
www.AutocADDetails.net

**SIMPSON**  
**Strong-Tie**  
**LTA1**

®



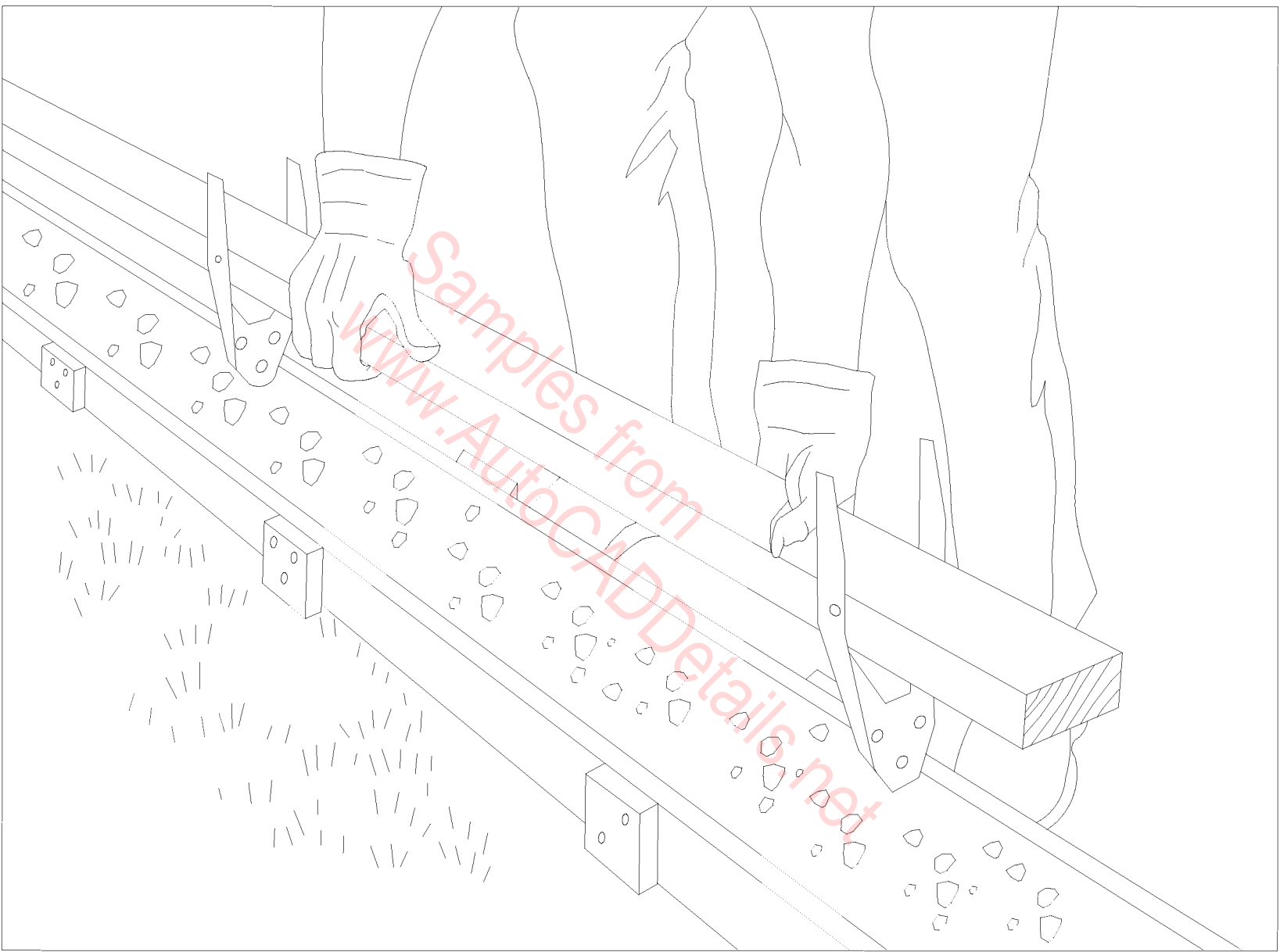

**Simpson Strong-Tie  
MA**

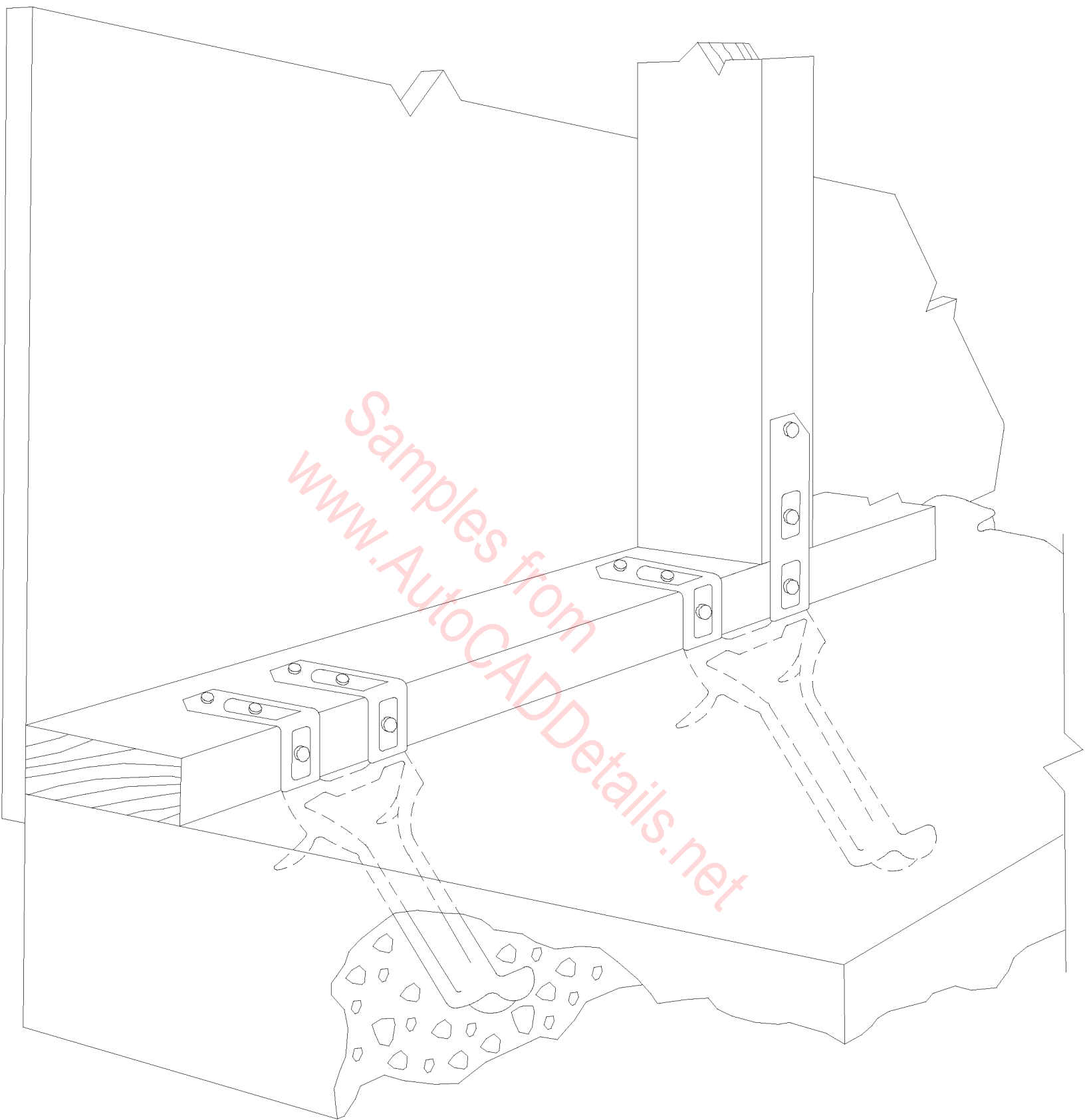

**Simpson Strong-Tie  
MAS**

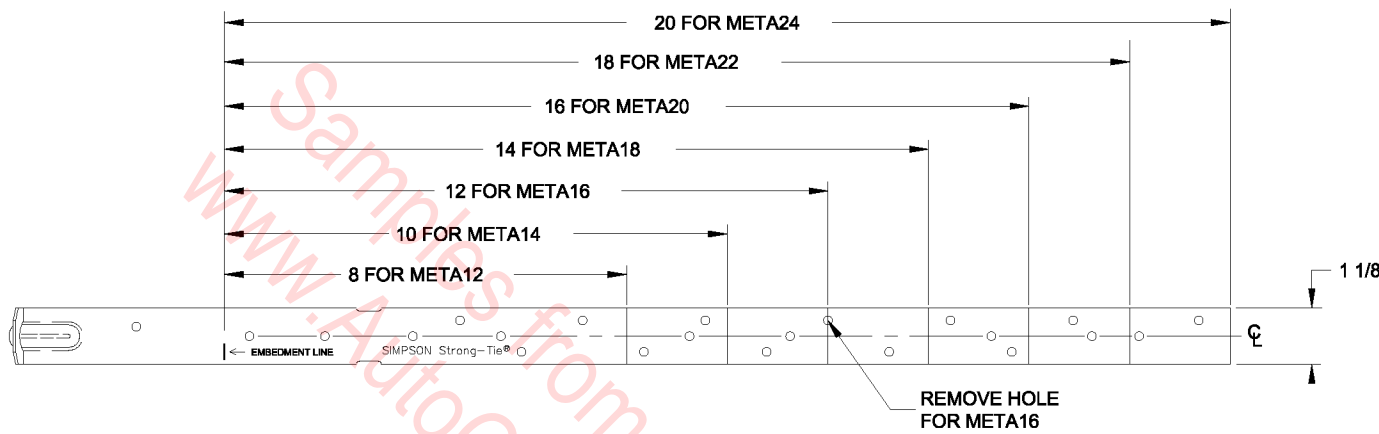

SIMPSON  
Strong-Tie®  
META

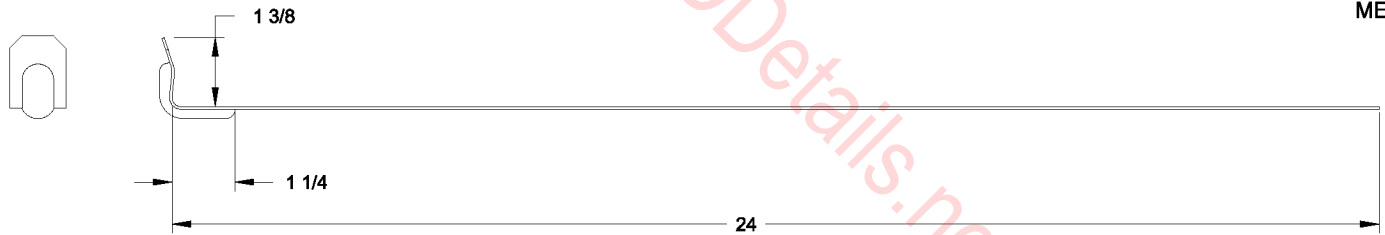

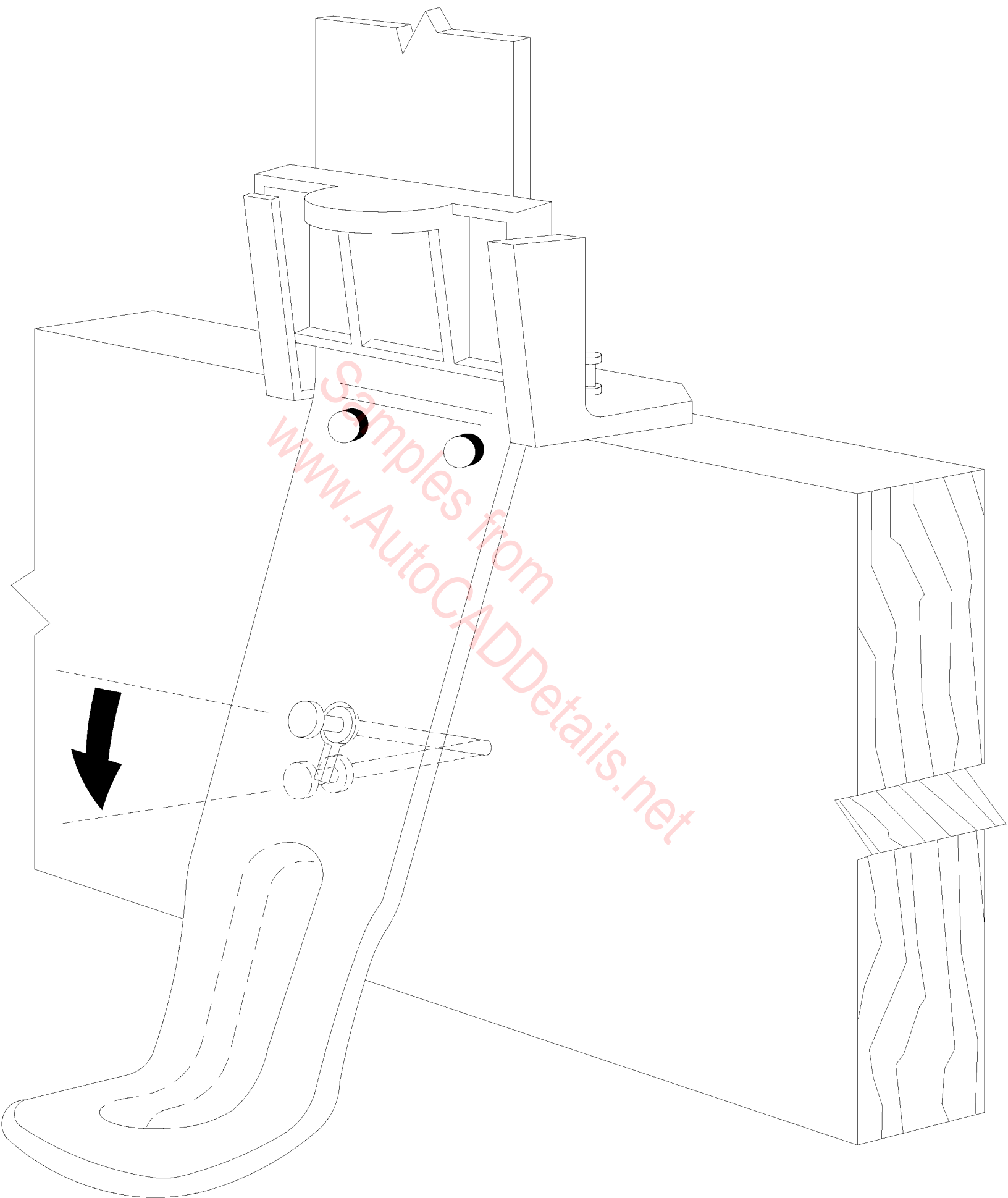

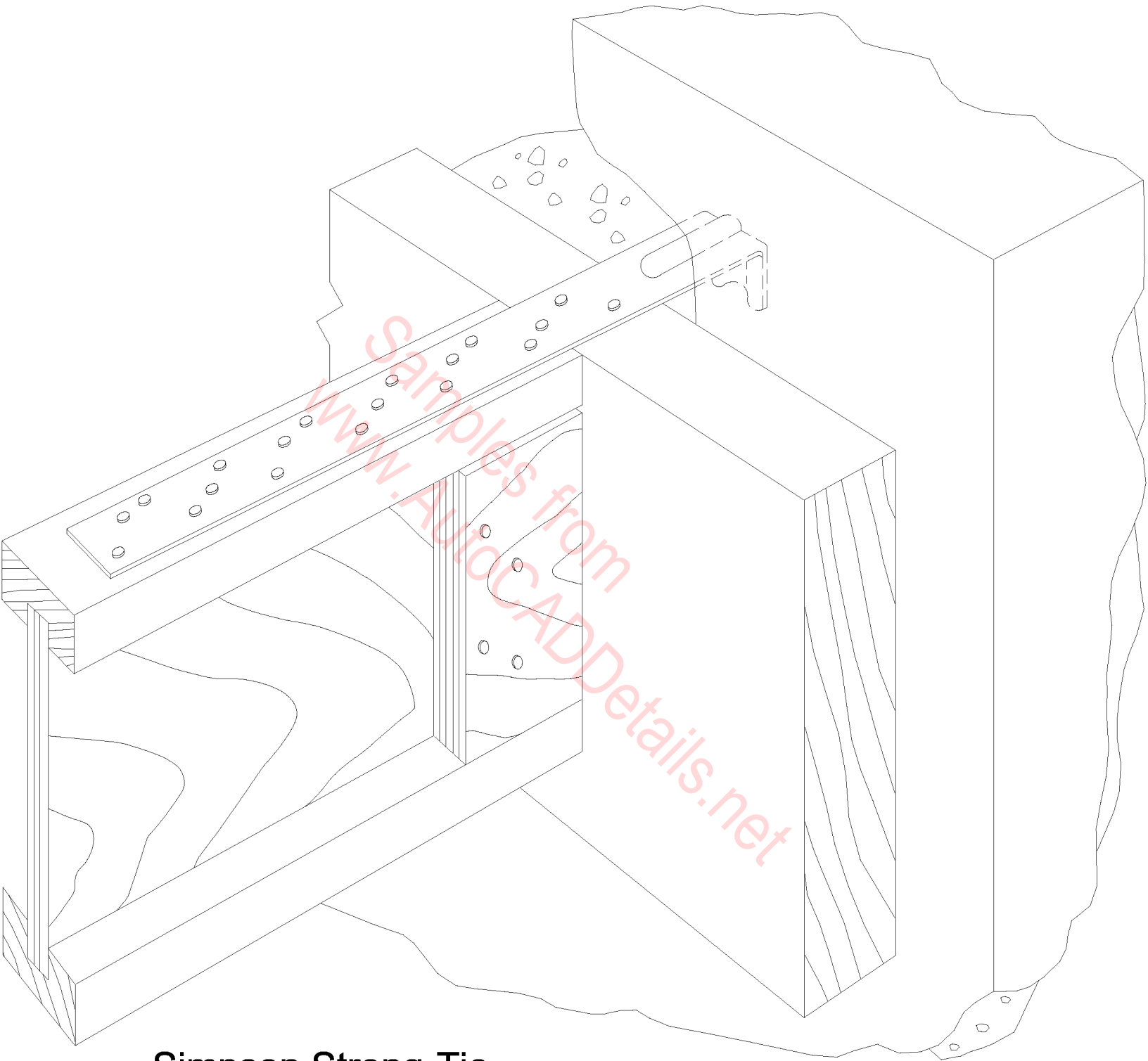

**Simpson Strong-Tie  
PAI35  
(Hanger not Shown)**

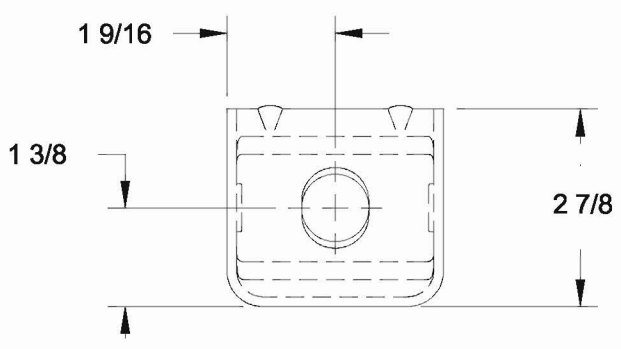
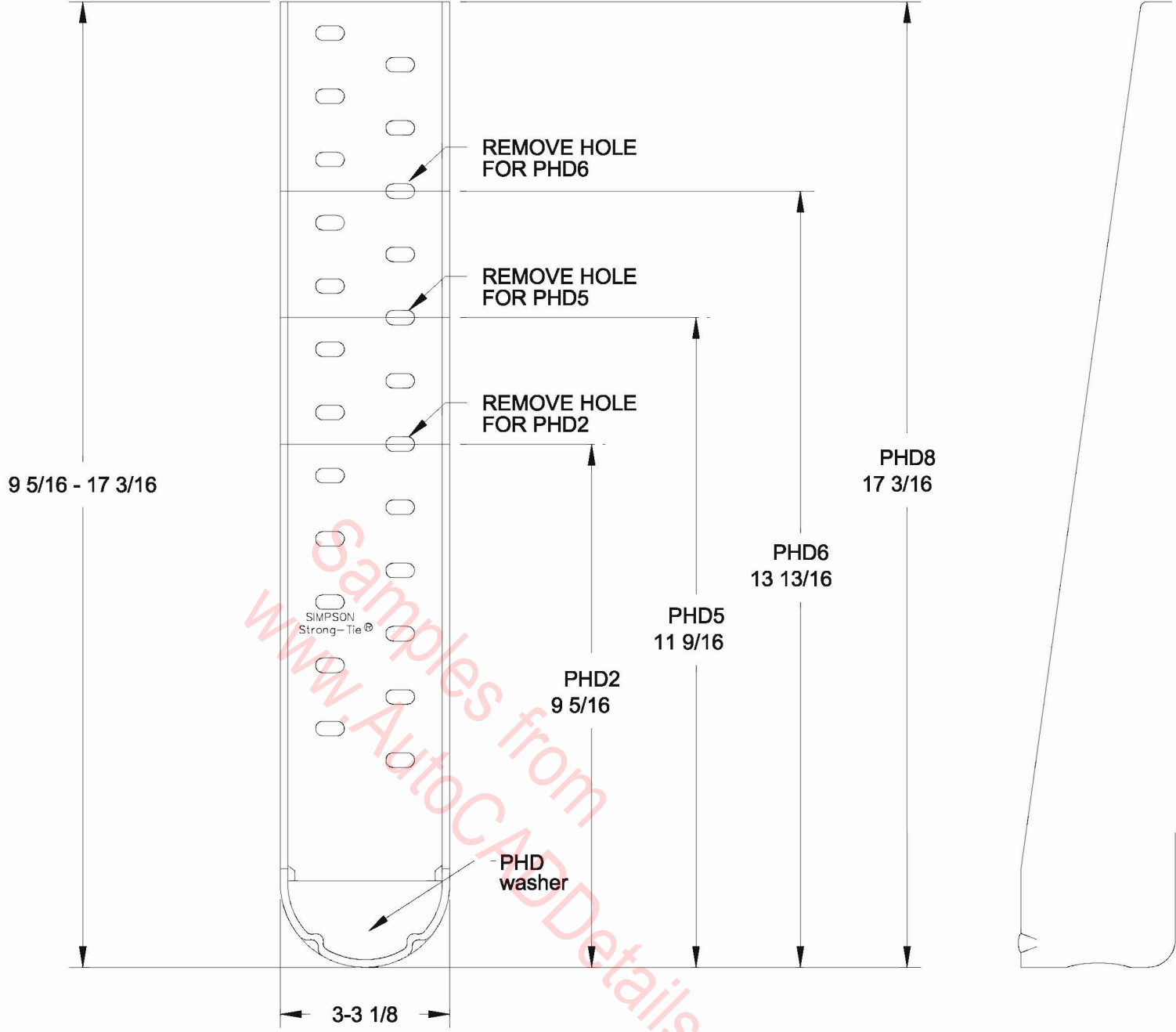

SIMPSON Strong-Tie®

**PHD**

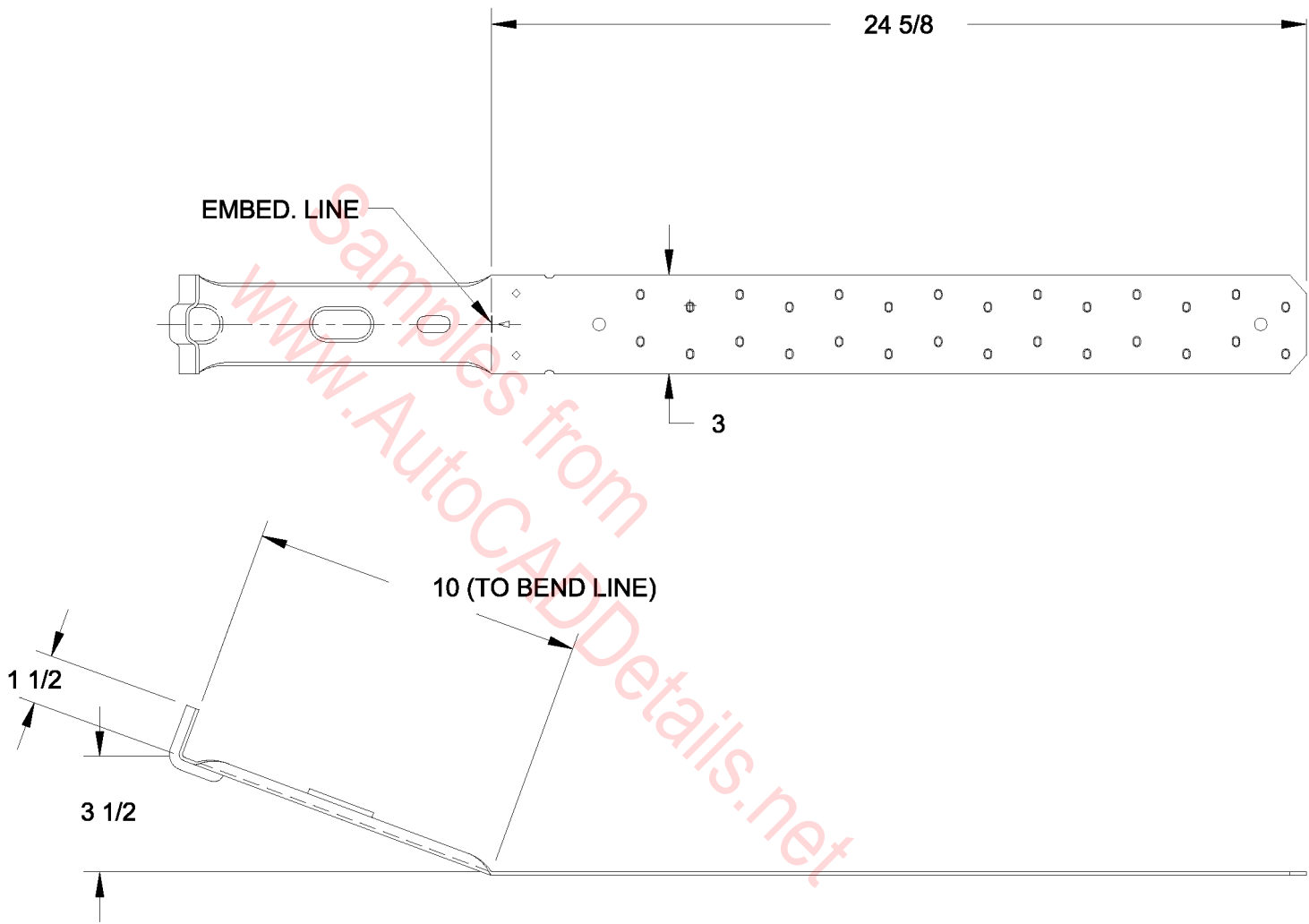

SIMPSON <sup>®</sup>  
Strong-Tie  
STHD10

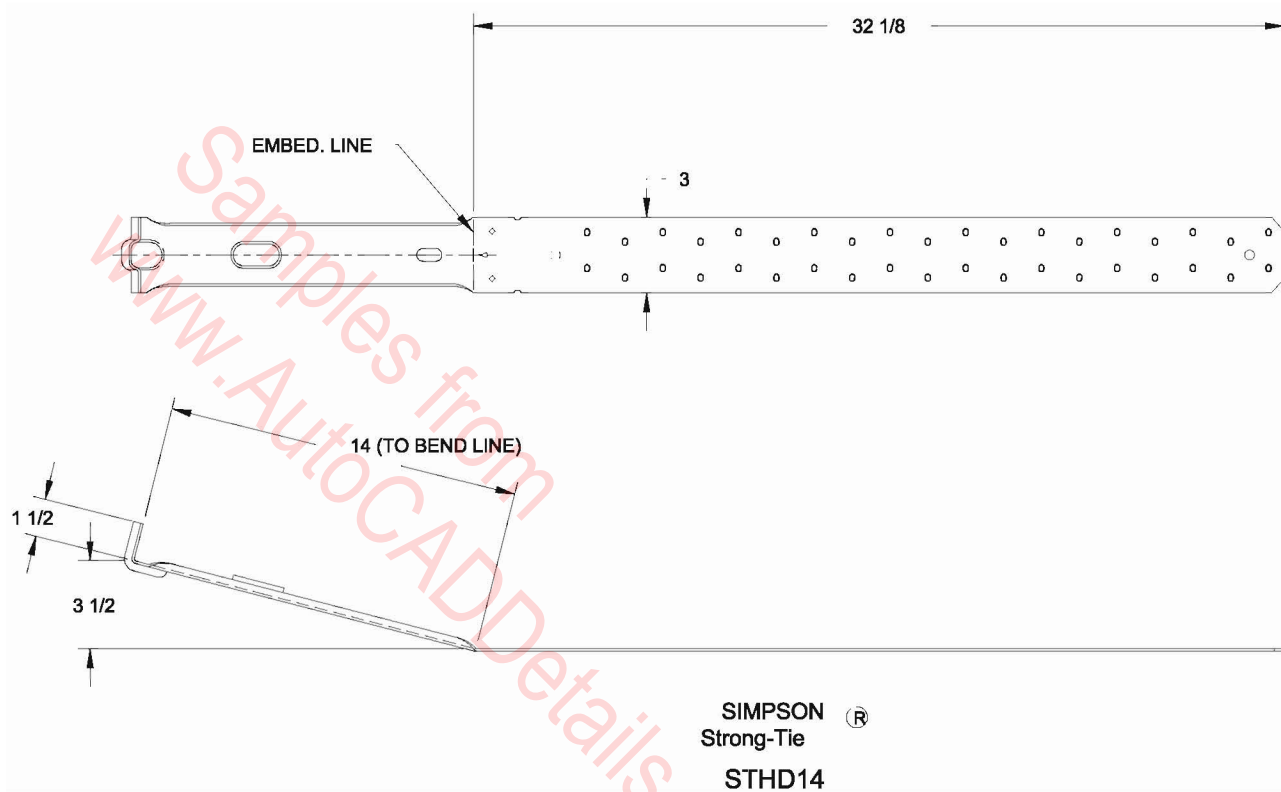



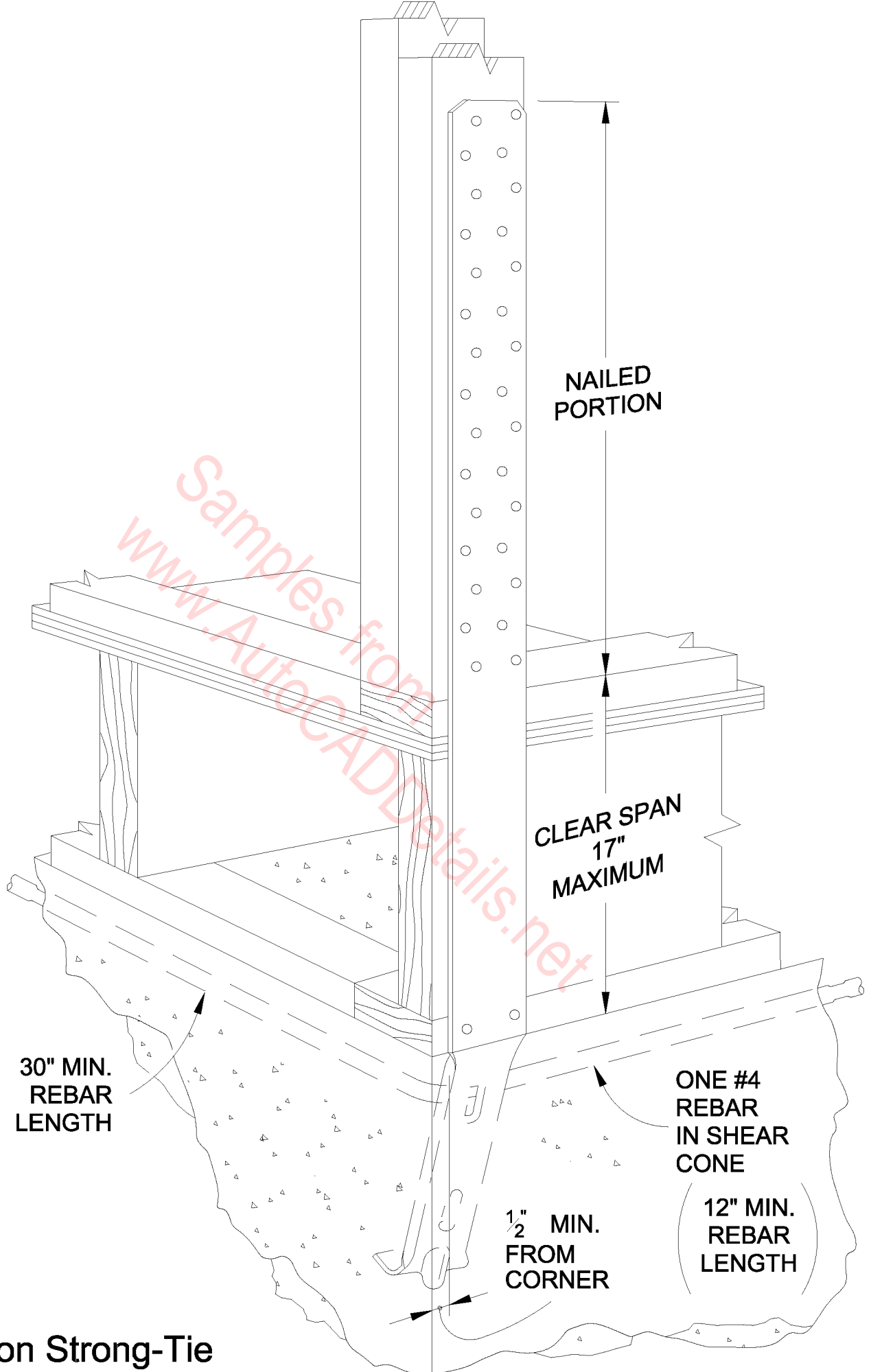

Simpson Strong-Tie  
STHD14RJ  
Rim Joist Installation

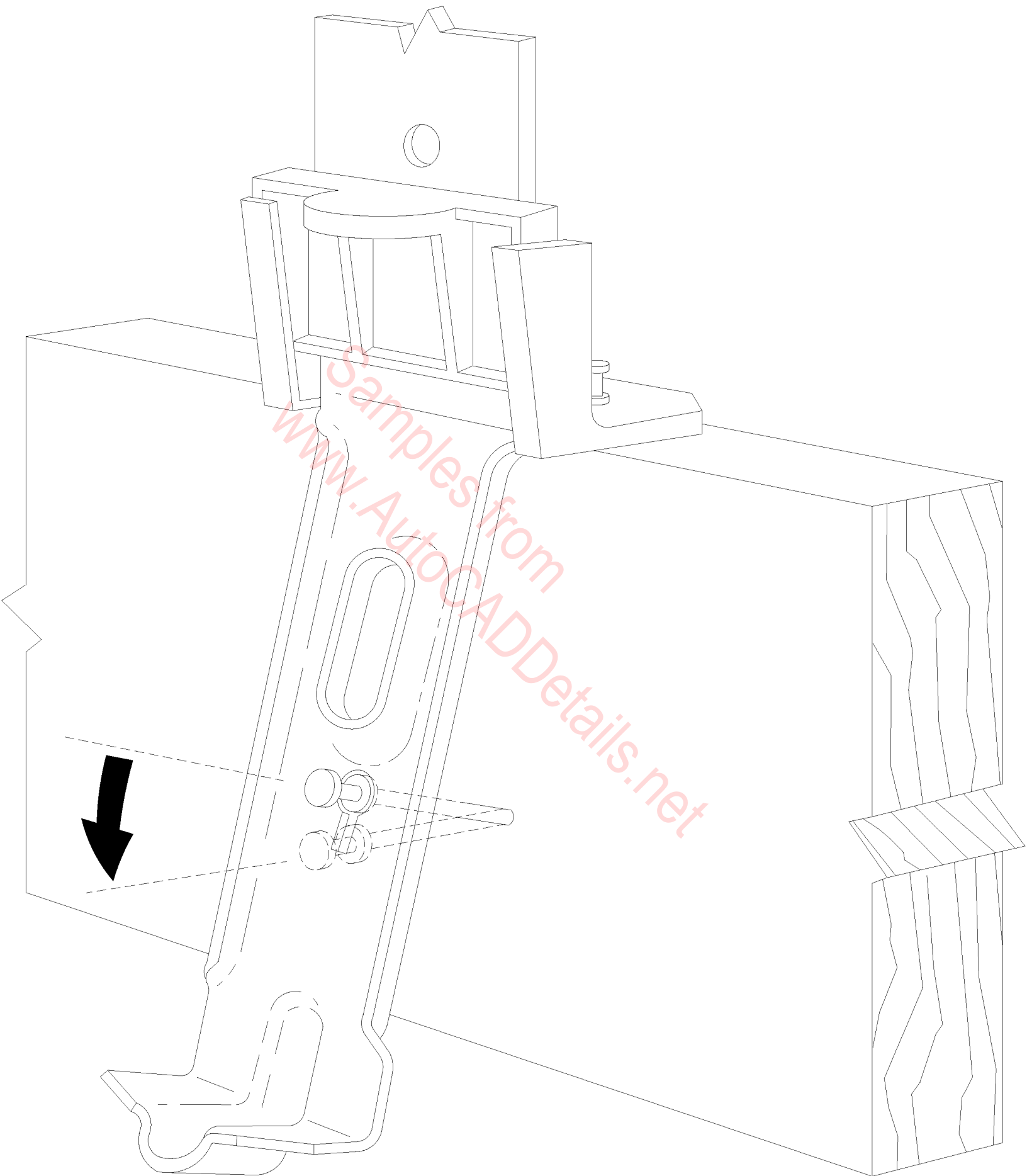

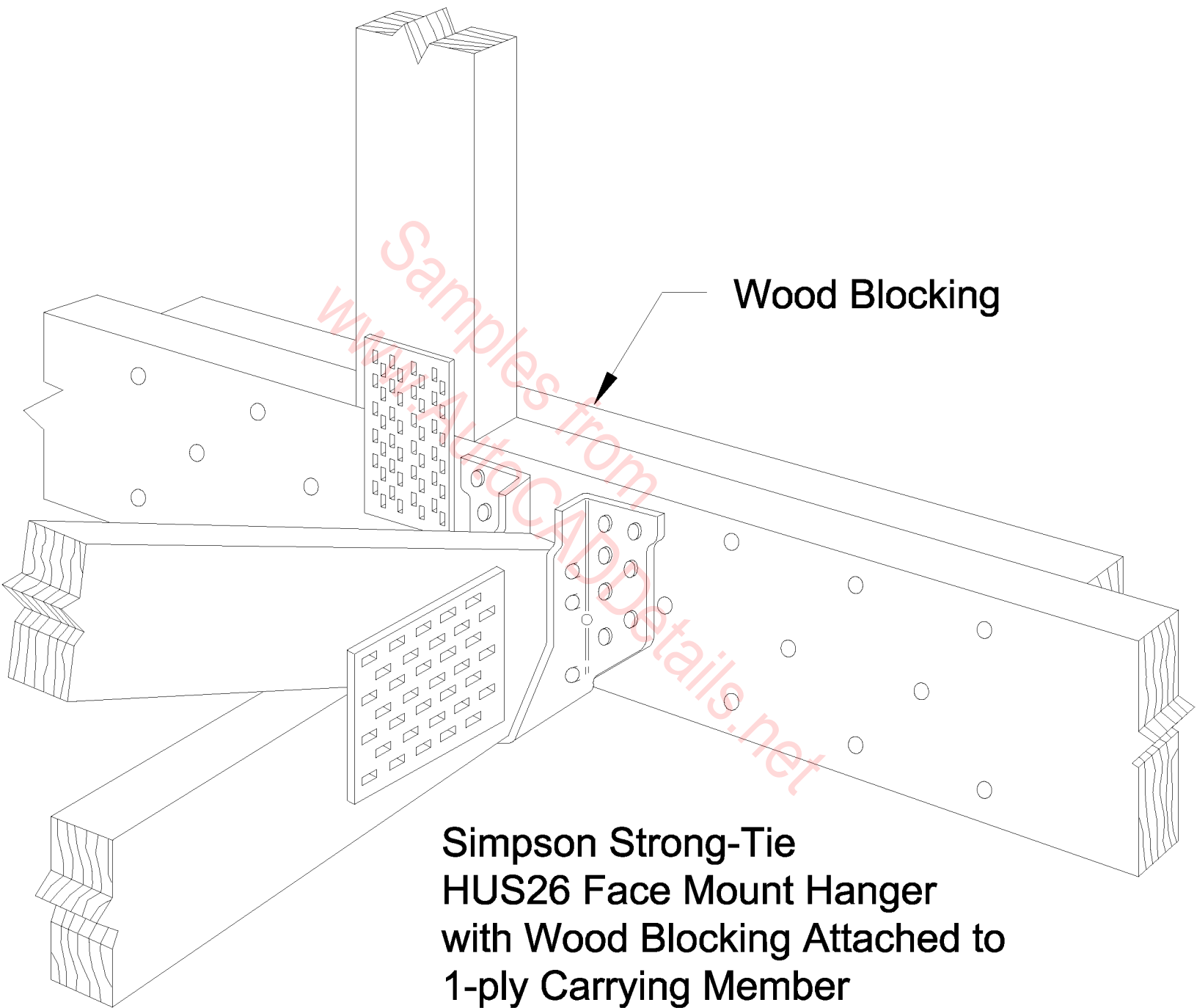

Wood Blocking

**Simpson Strong-Tie  
HUS26 Face Mount Hanger  
with Wood Blocking Attached to  
1-ply Carrying Member**

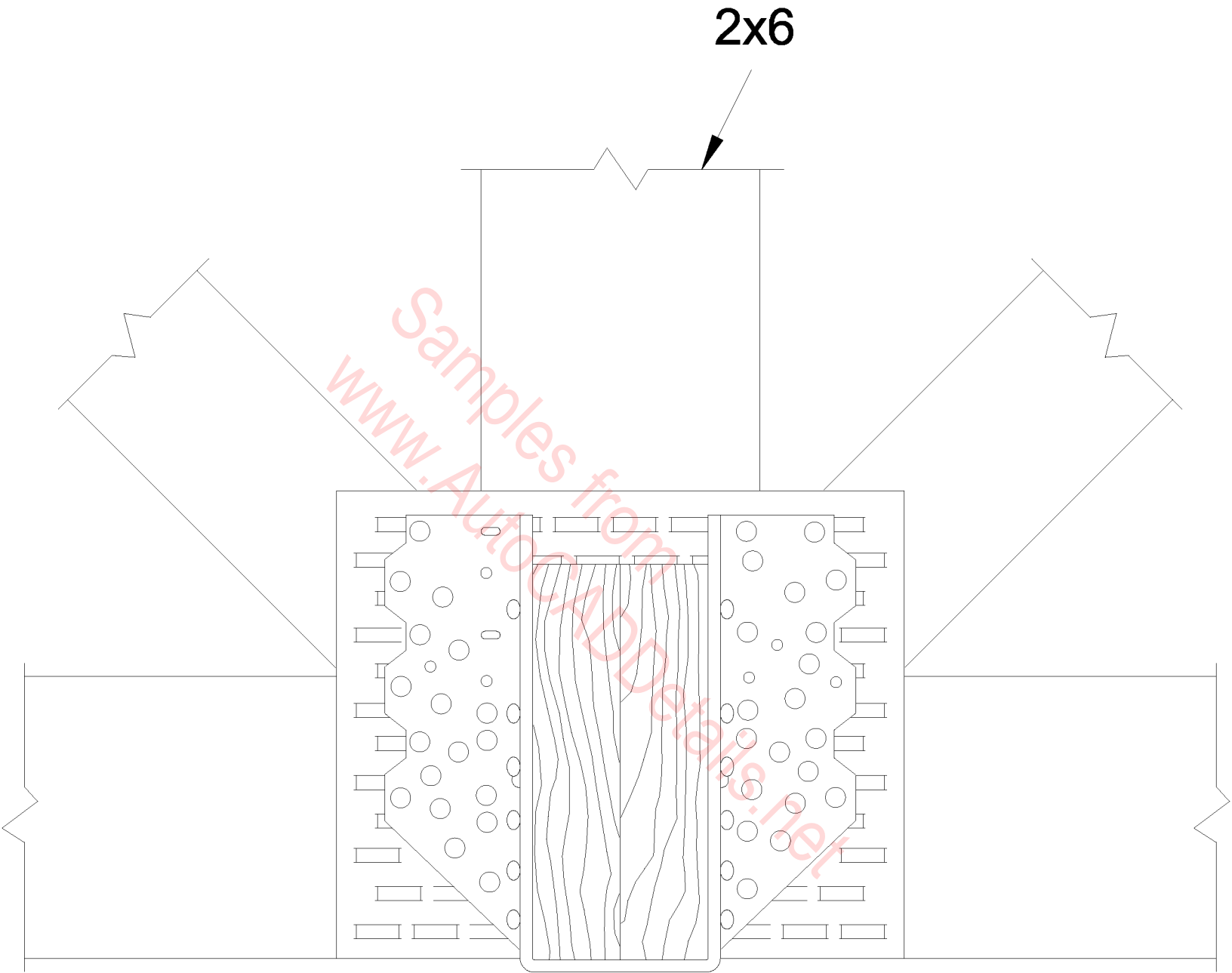

**Simpson Strong-Tie  
HGUS210-2 on  
2x6 Bottom Chord**

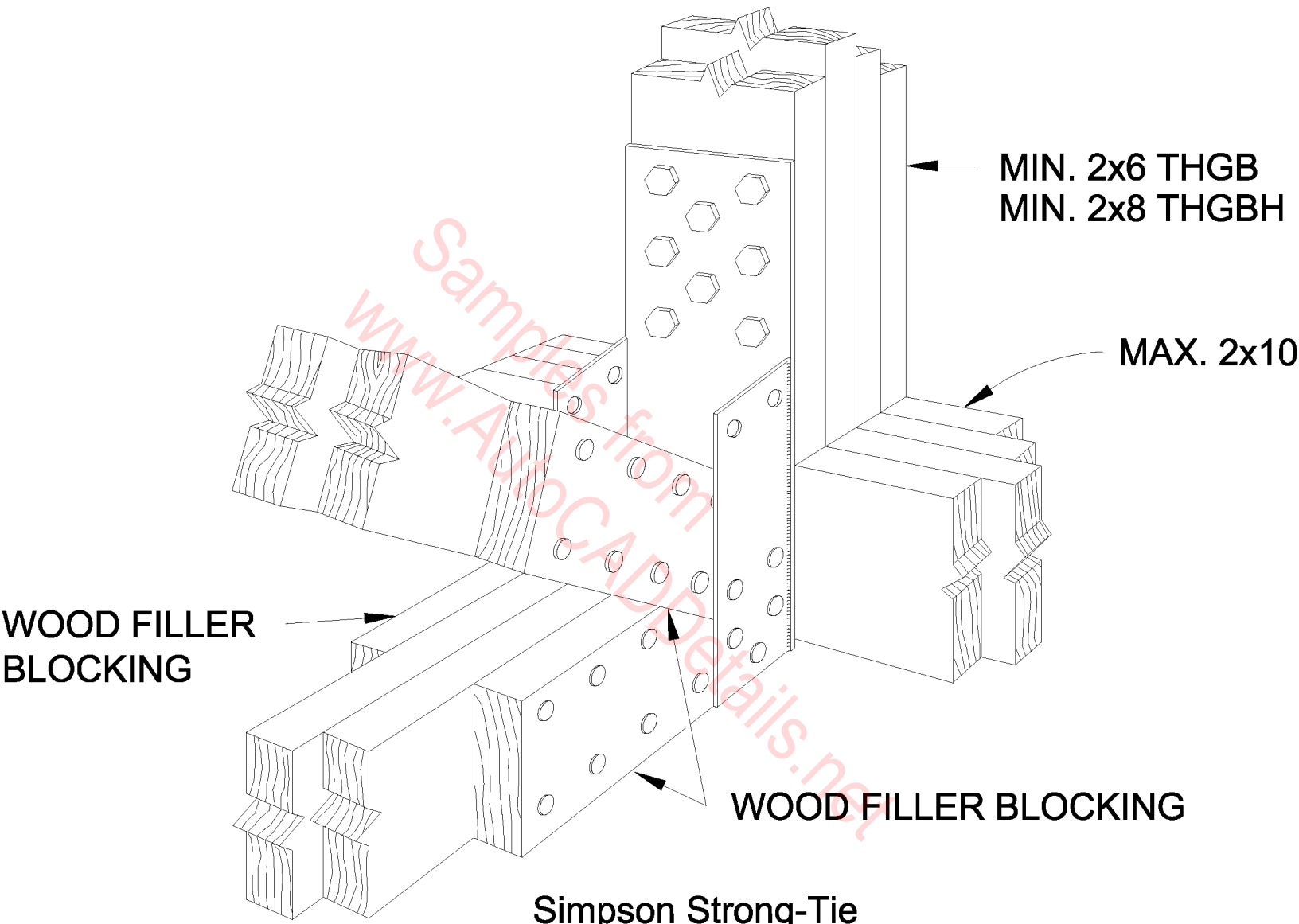

MIN. 2x6 THGB  
MIN. 2x8 THGBH

MAX. 2x10

WOOD FILLER  
BLOCKING

WOOD FILLER BLOCKING

Simpson Strong-Tie  
THGB/THGBH with  
Wood Filler Blocking Attached to  
Carried Member

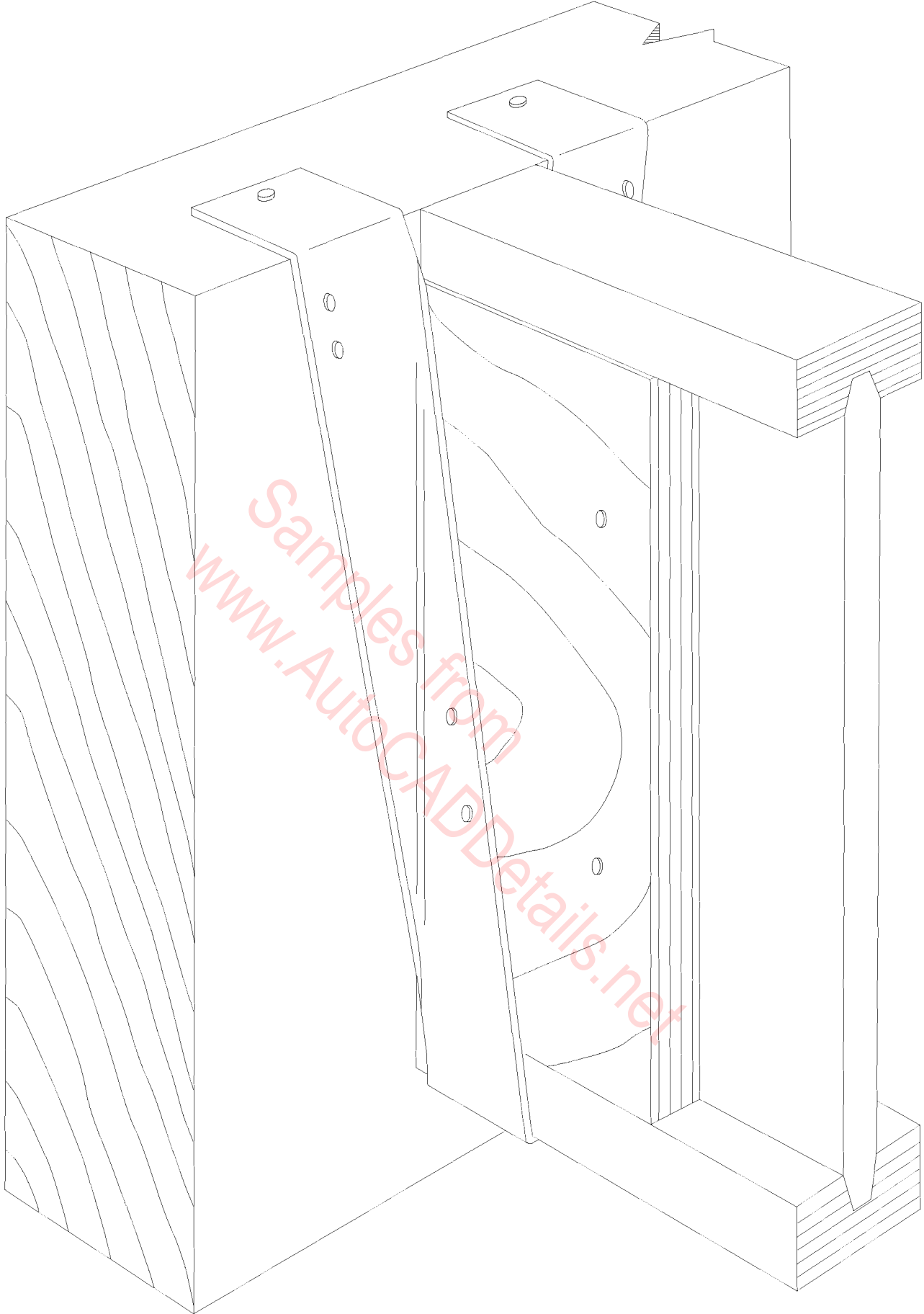

**Simpson Strong-Tie  
BI**

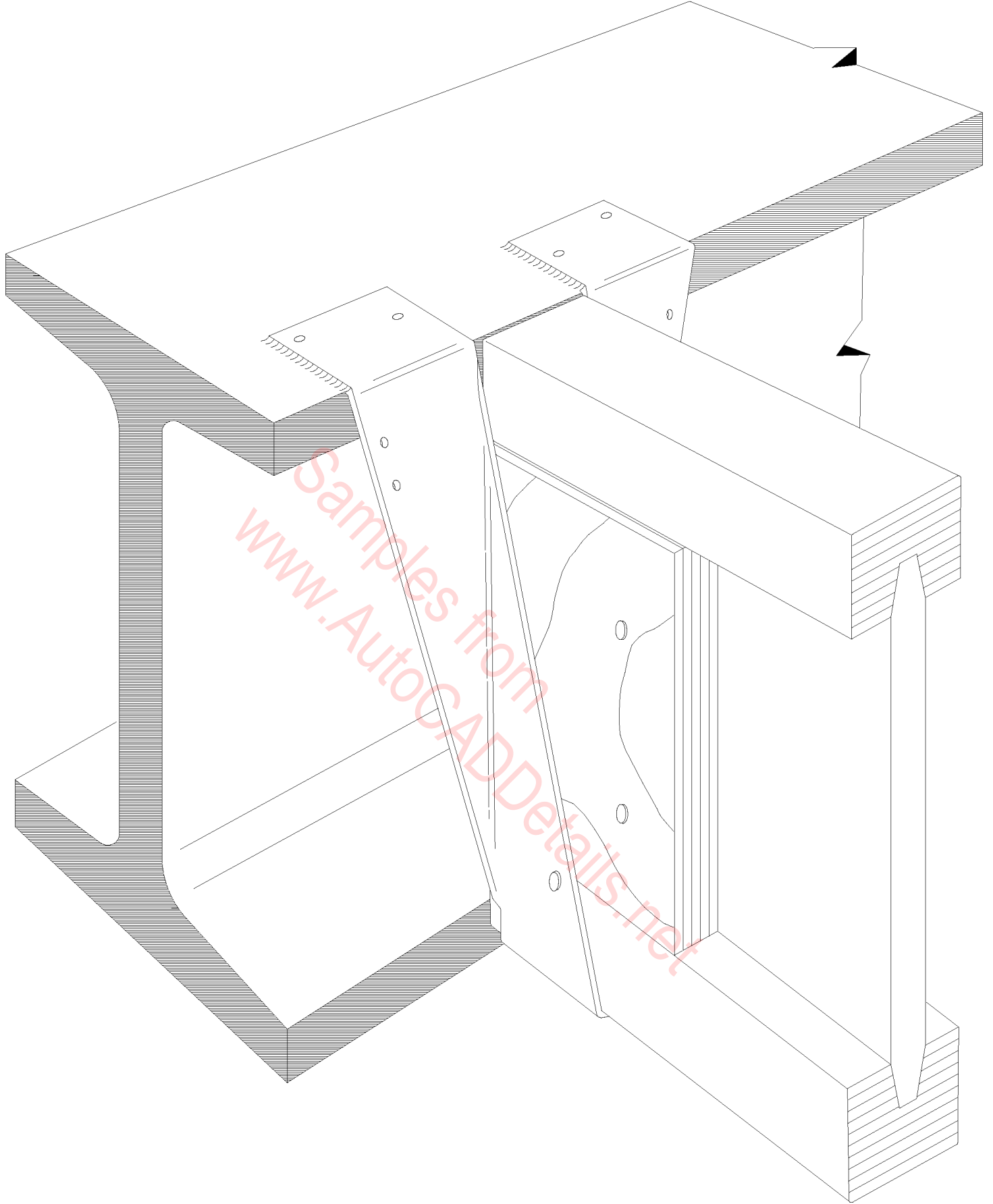

**Simpson Strong-Tie**  
**BI Hanger welded on 8"x14" steel I-beam**  
**Installation with I-Joist**

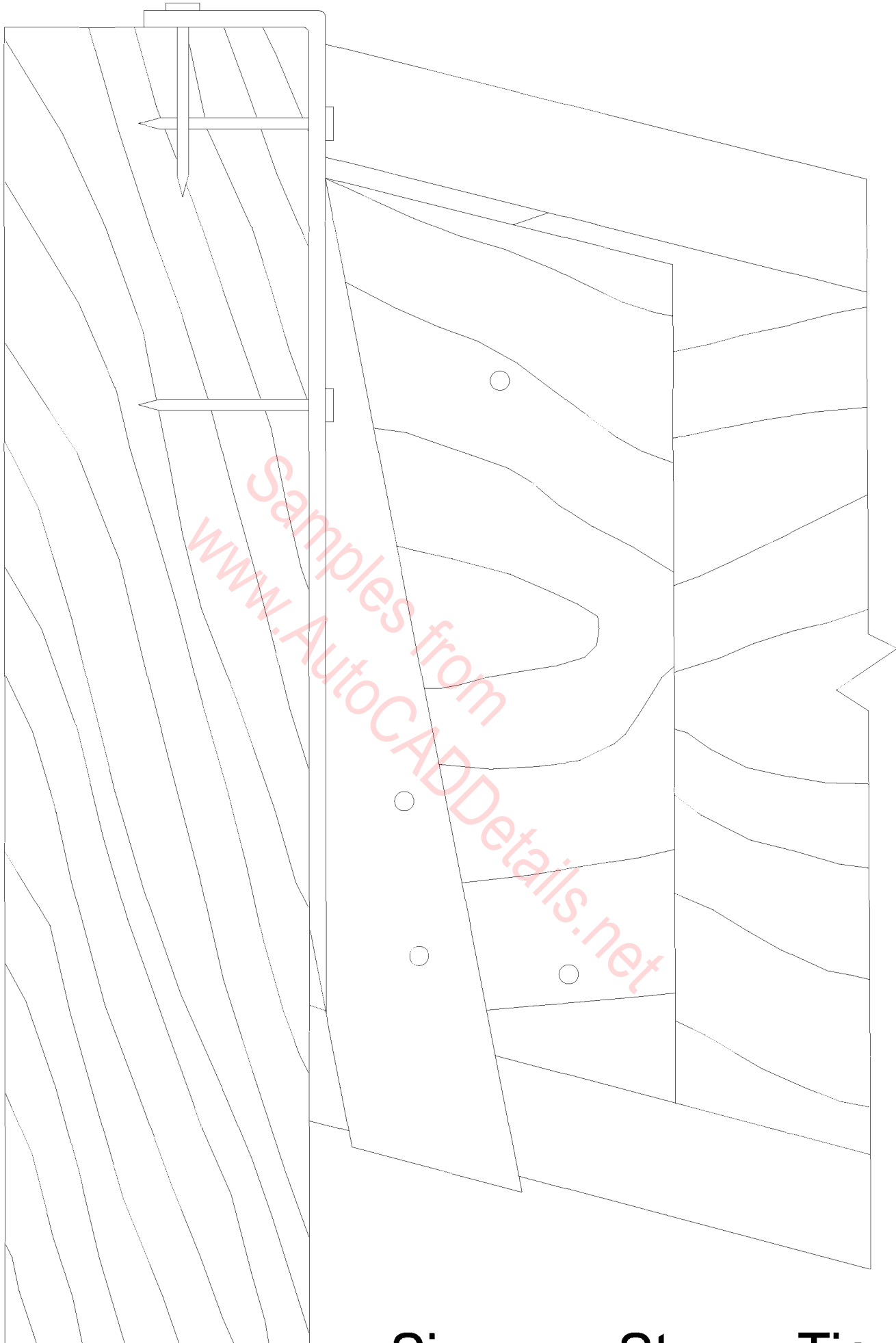

Samples from  
[www.AutoCADDetails.net](http://www.AutoCADDetails.net)

**Simpson Strong-Tie  
BI Sloped Down**



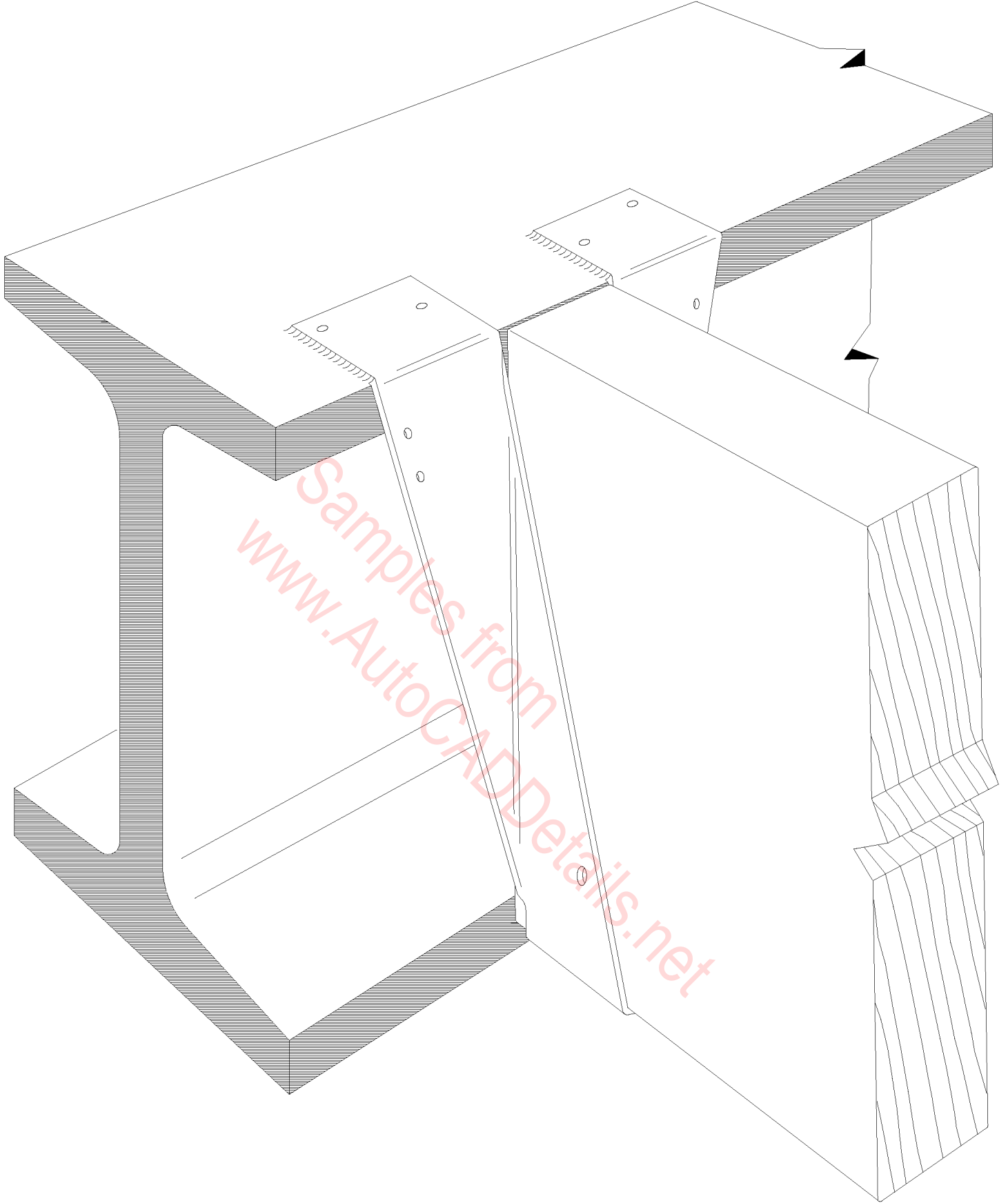

**B HANGER WELDED ON 8"X14" STEEL I-BEAM**

**Simpson Strong-Tie**

**B**

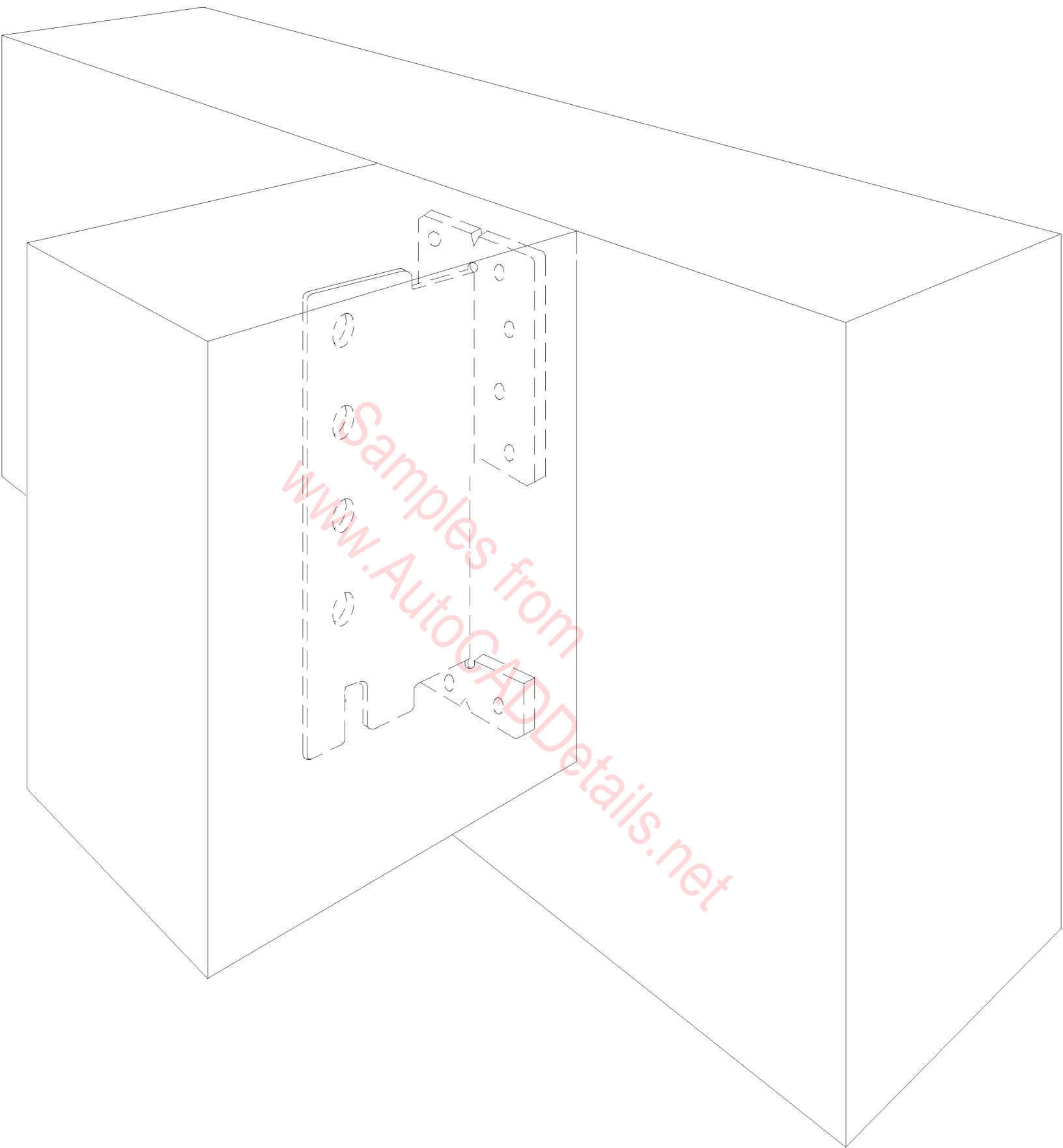

**Simpson Strong-Tie  
CJT**

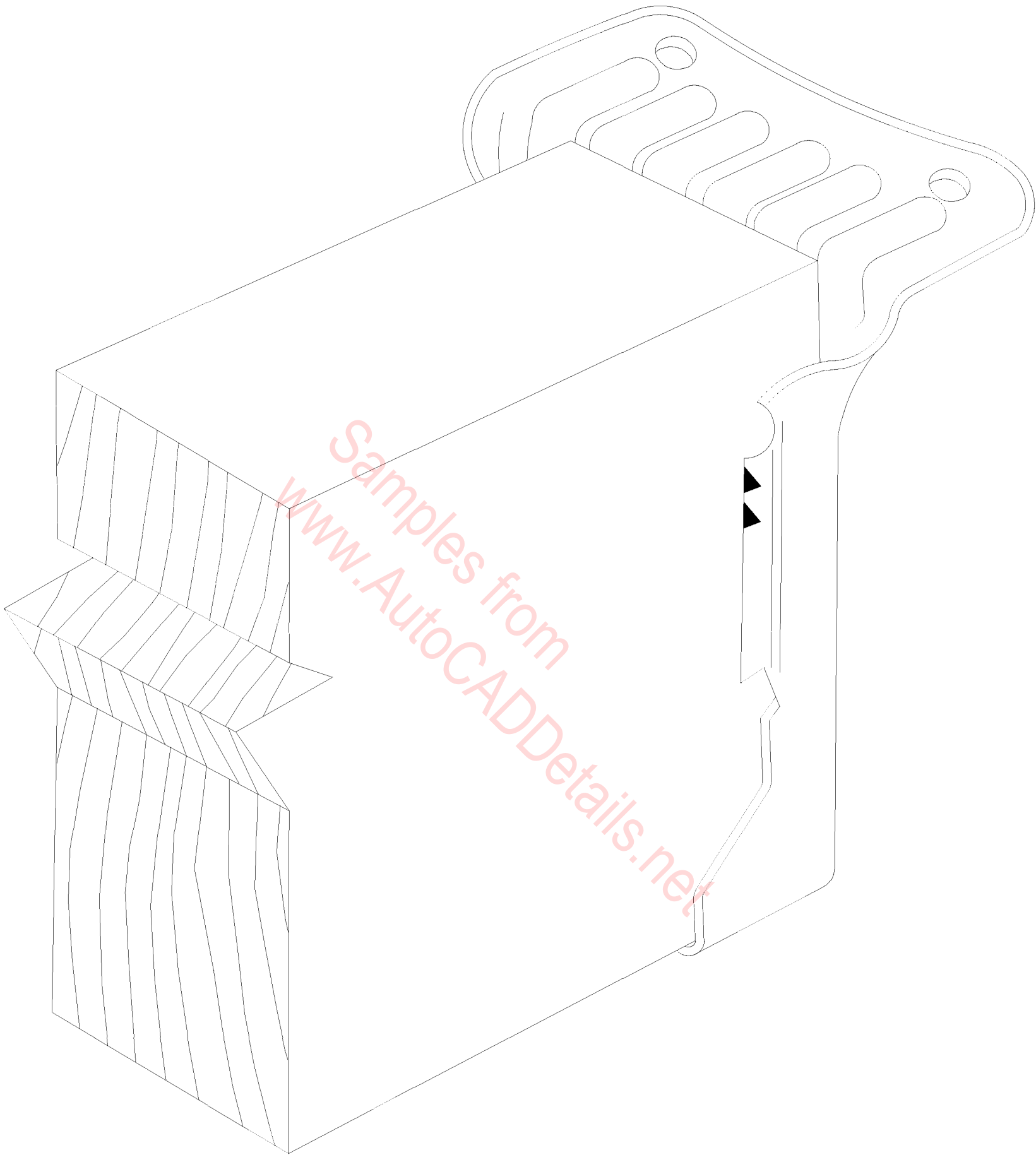

**Simpson Strong-Tie  
F24N or F26N**

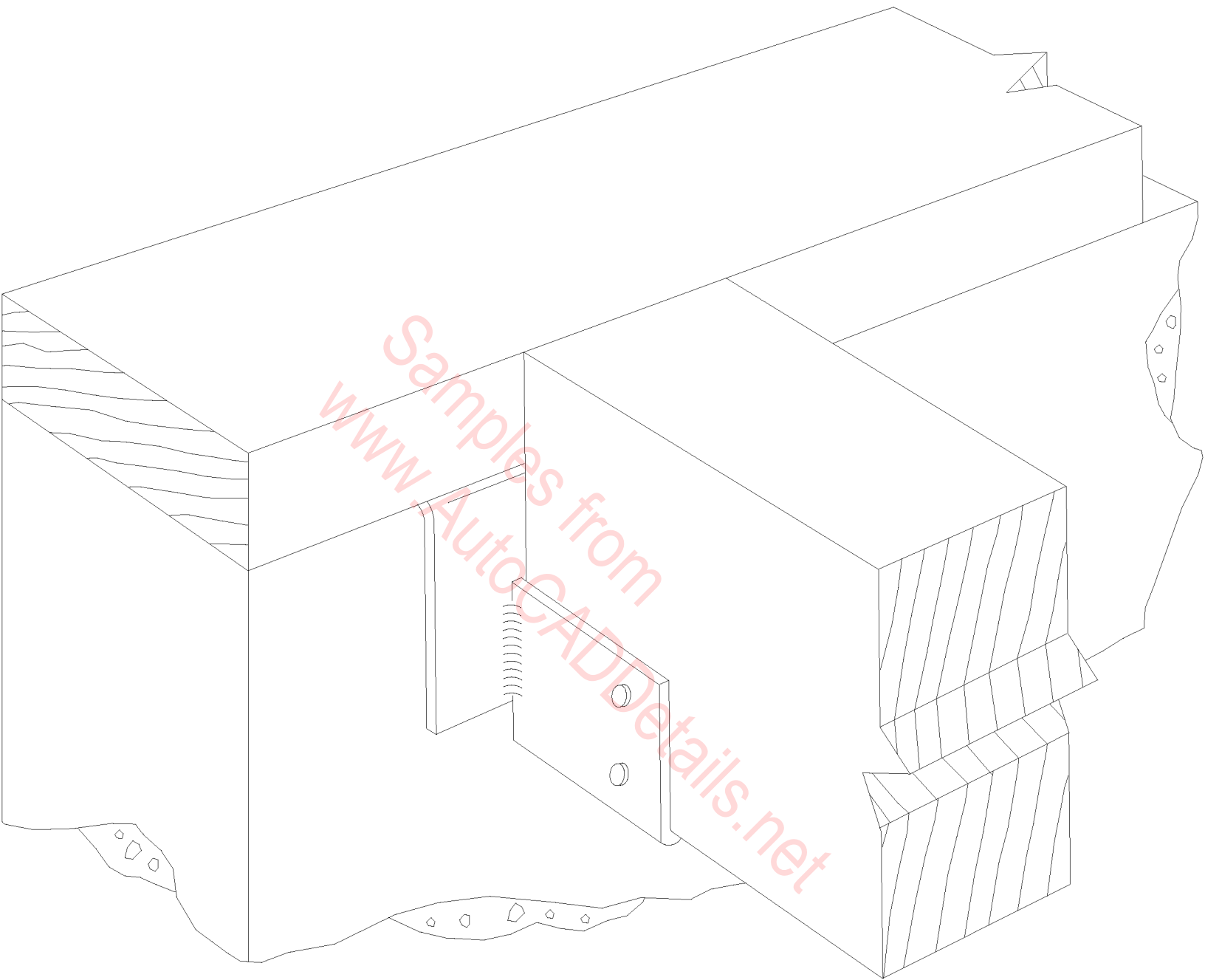

**Simpson Strong-Tie  
GH46-6**

**CARRYING  
BEAM**

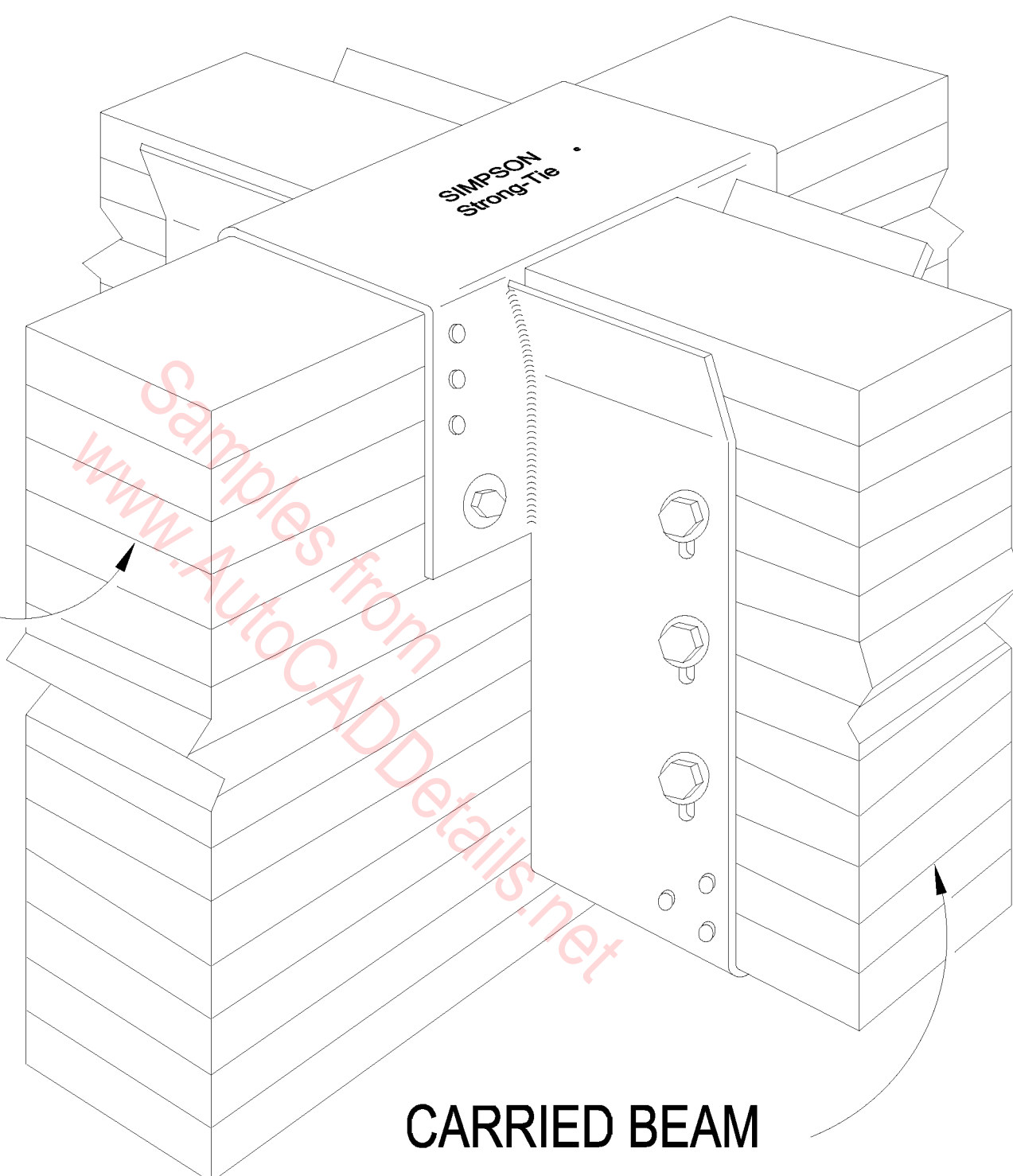

**CARRIED BEAM**

**Simpson Strong-Tie  
GLST**

**SPECIFY LOW SIDE, HIGH SIDE,  
OR CENTER FLUSH WITH HEADER  
(LOW SIDE FLUSH SHOWN)**

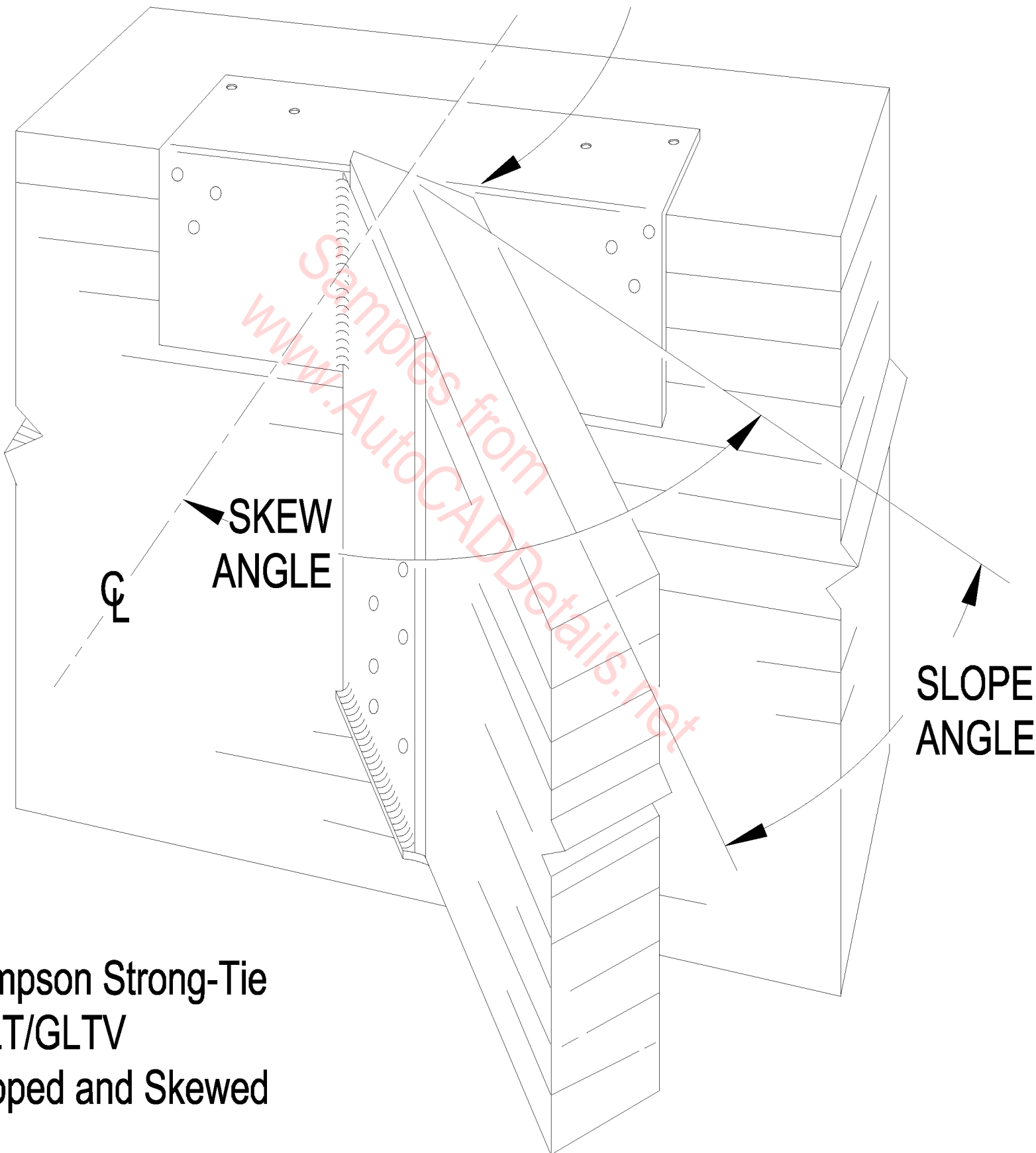

**Simpson Strong-Tie  
GLT/GLTV  
Sloped and Skewed**

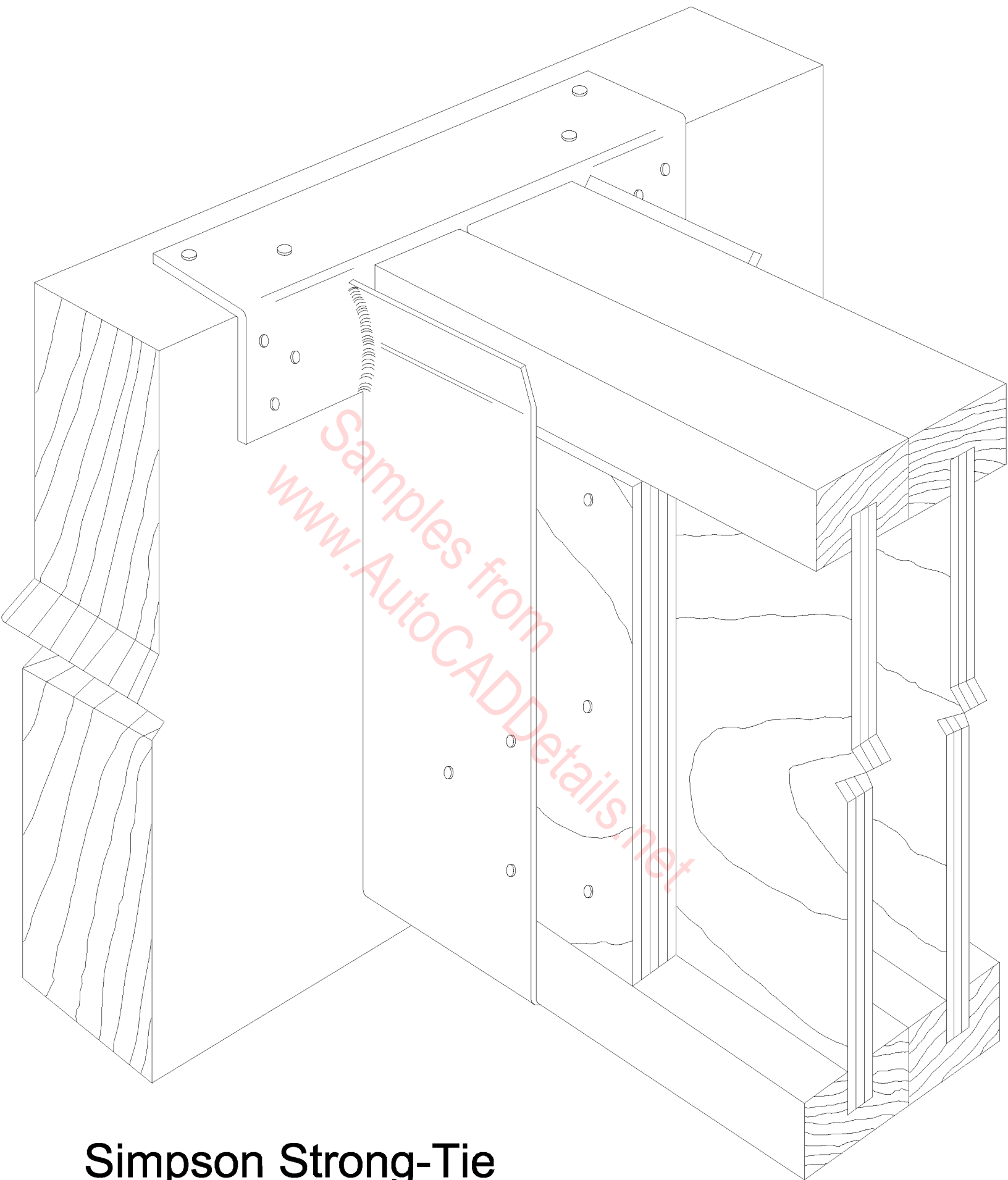

**Simpson Strong-Tie  
GLTV  
(installed with double wood web)**

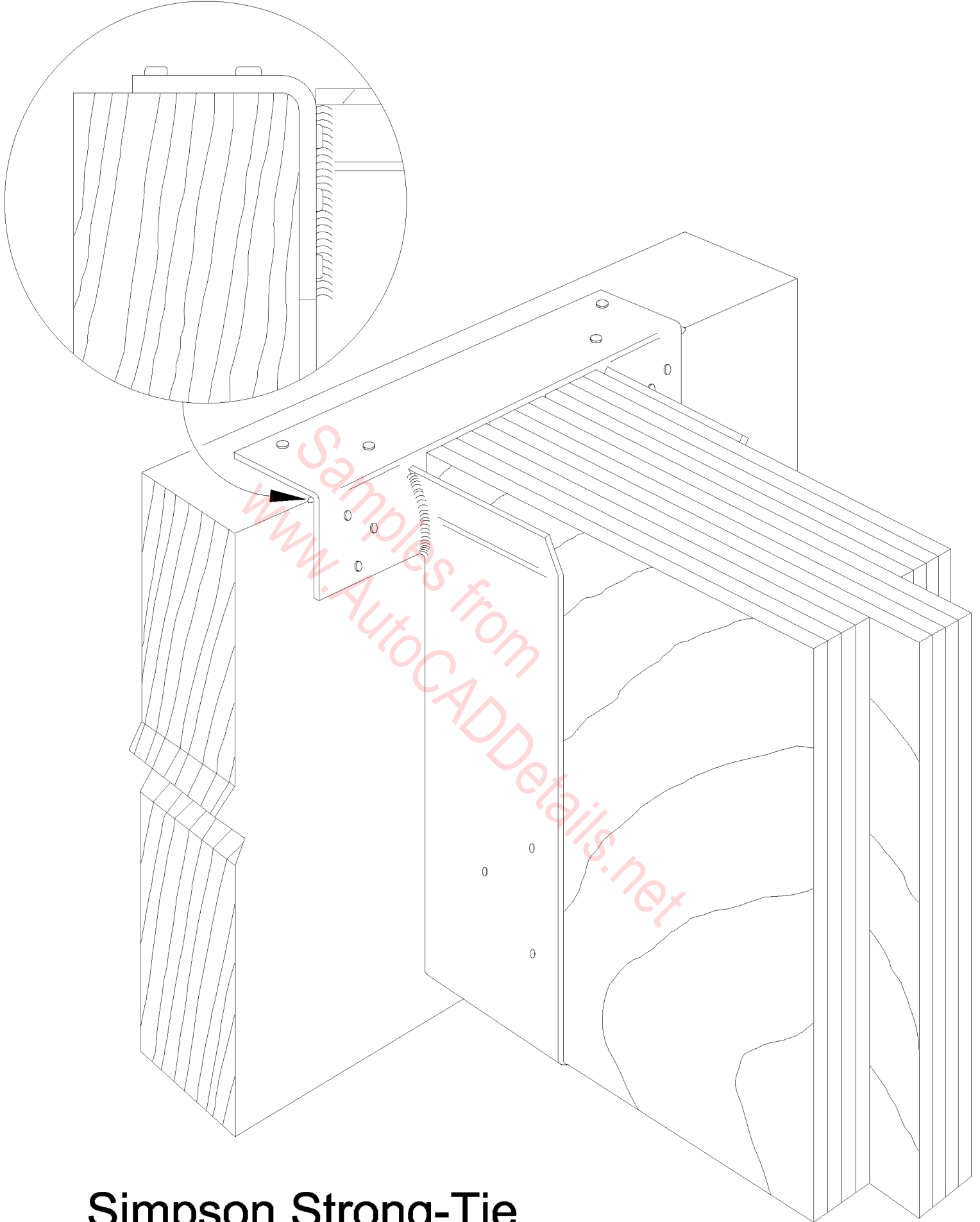

**Simpson Strong-Tie  
GLTV  
(Installation with Triple LVL)**



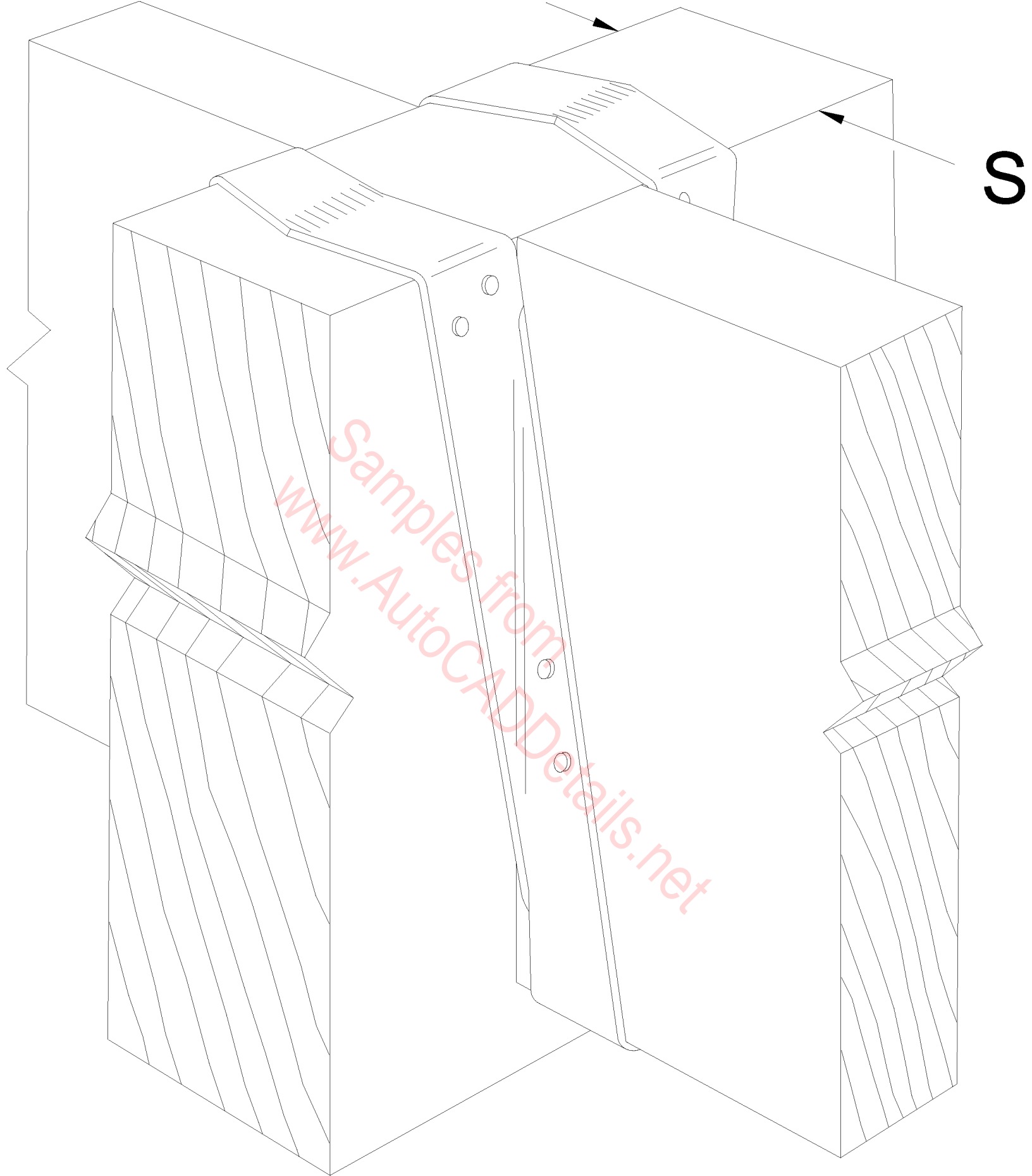

**Simpson Strong-Tie  
HB**

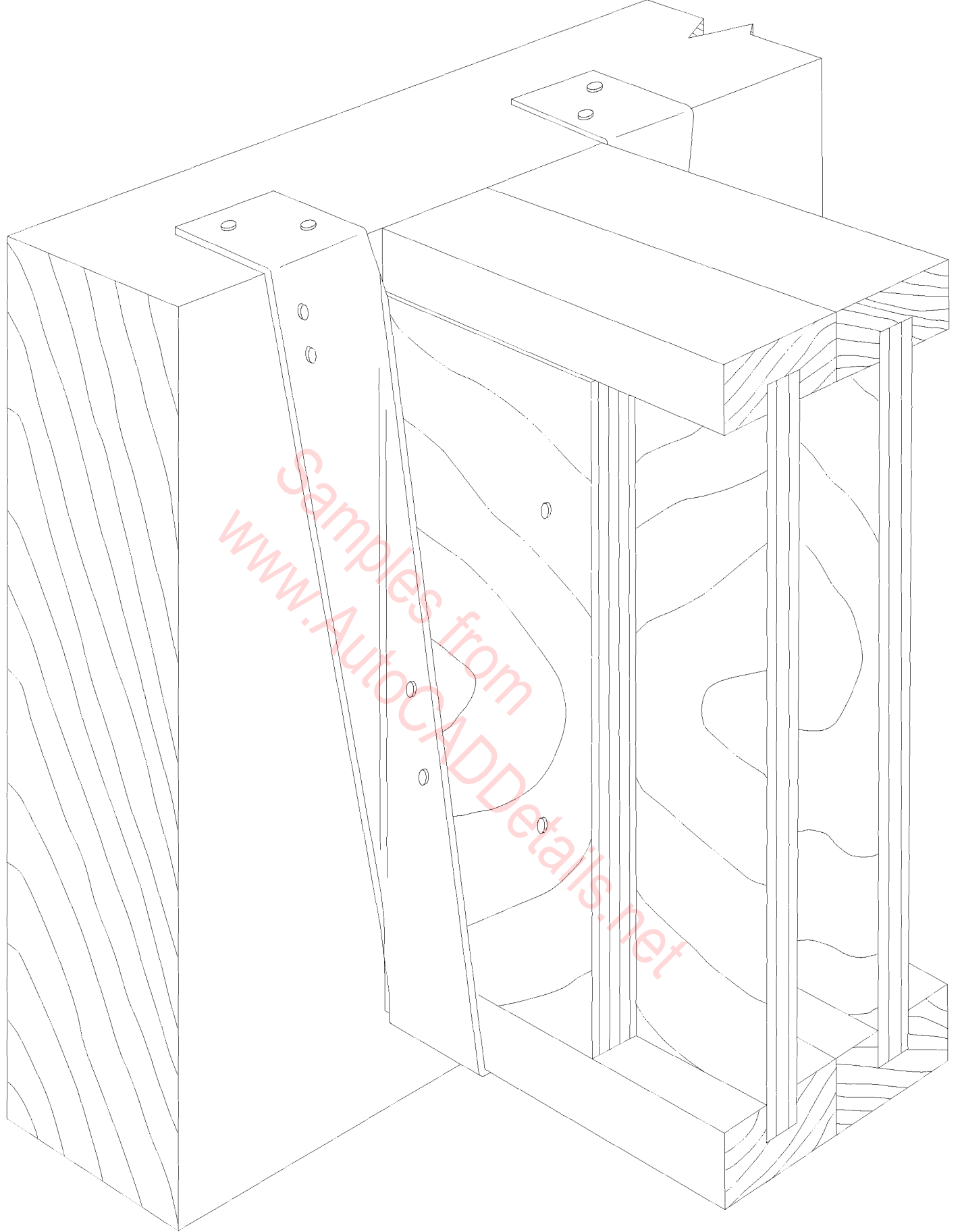

**Simpson Strong-Tie  
HBI-2 (Double)**

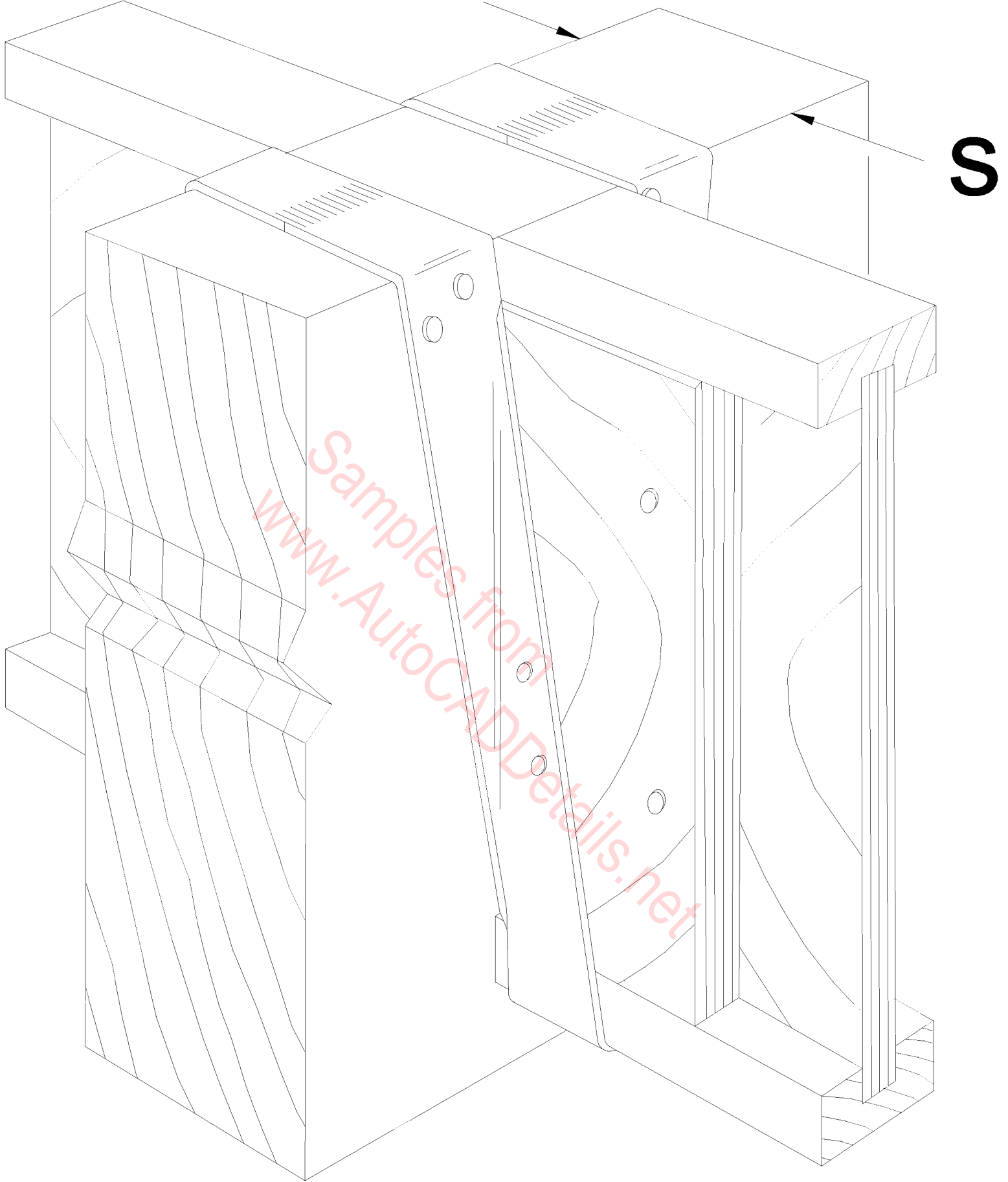

**Simpson Strong-Tie  
HBID**

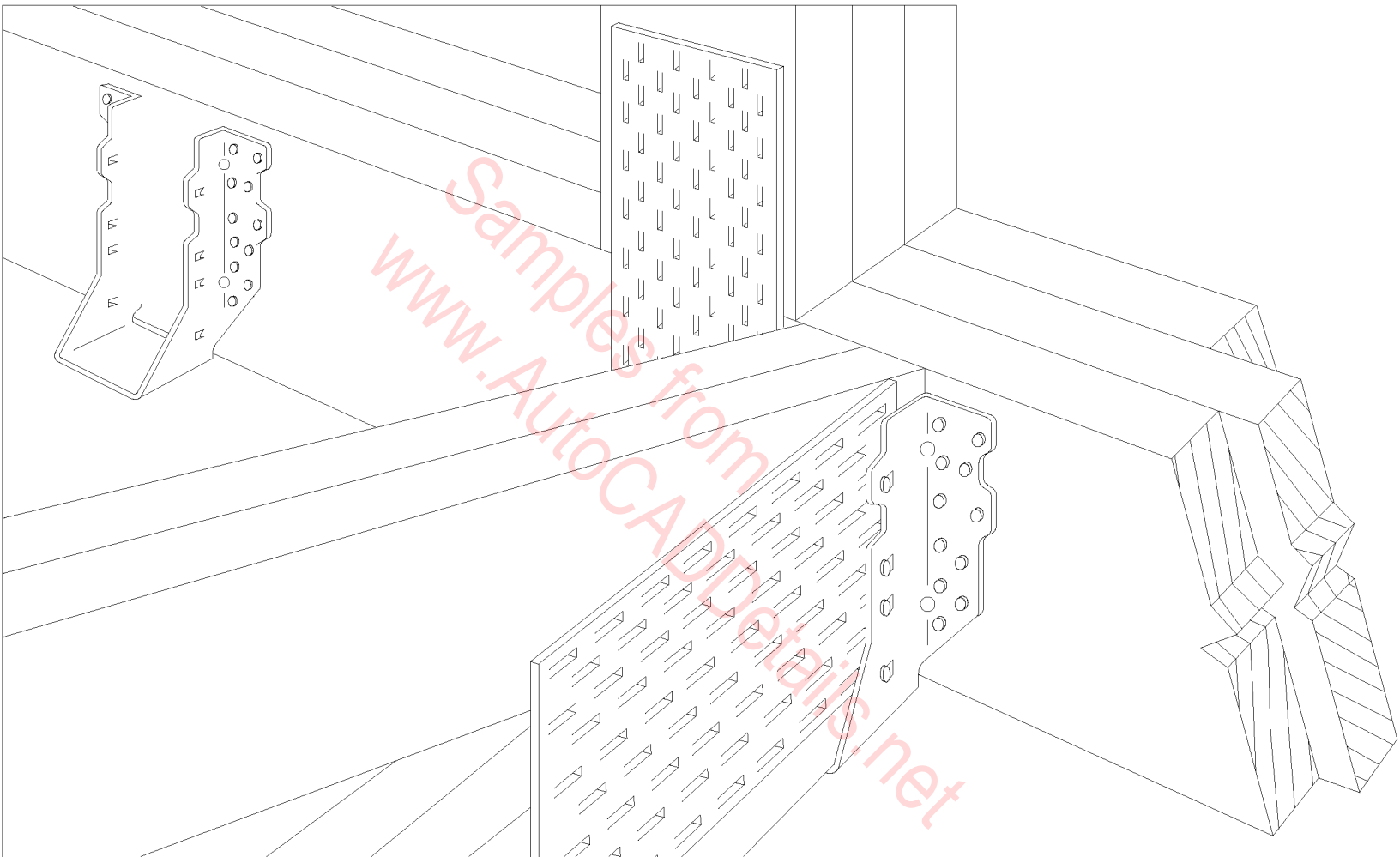

**Simpson Strong-Tie  
HHUS28**

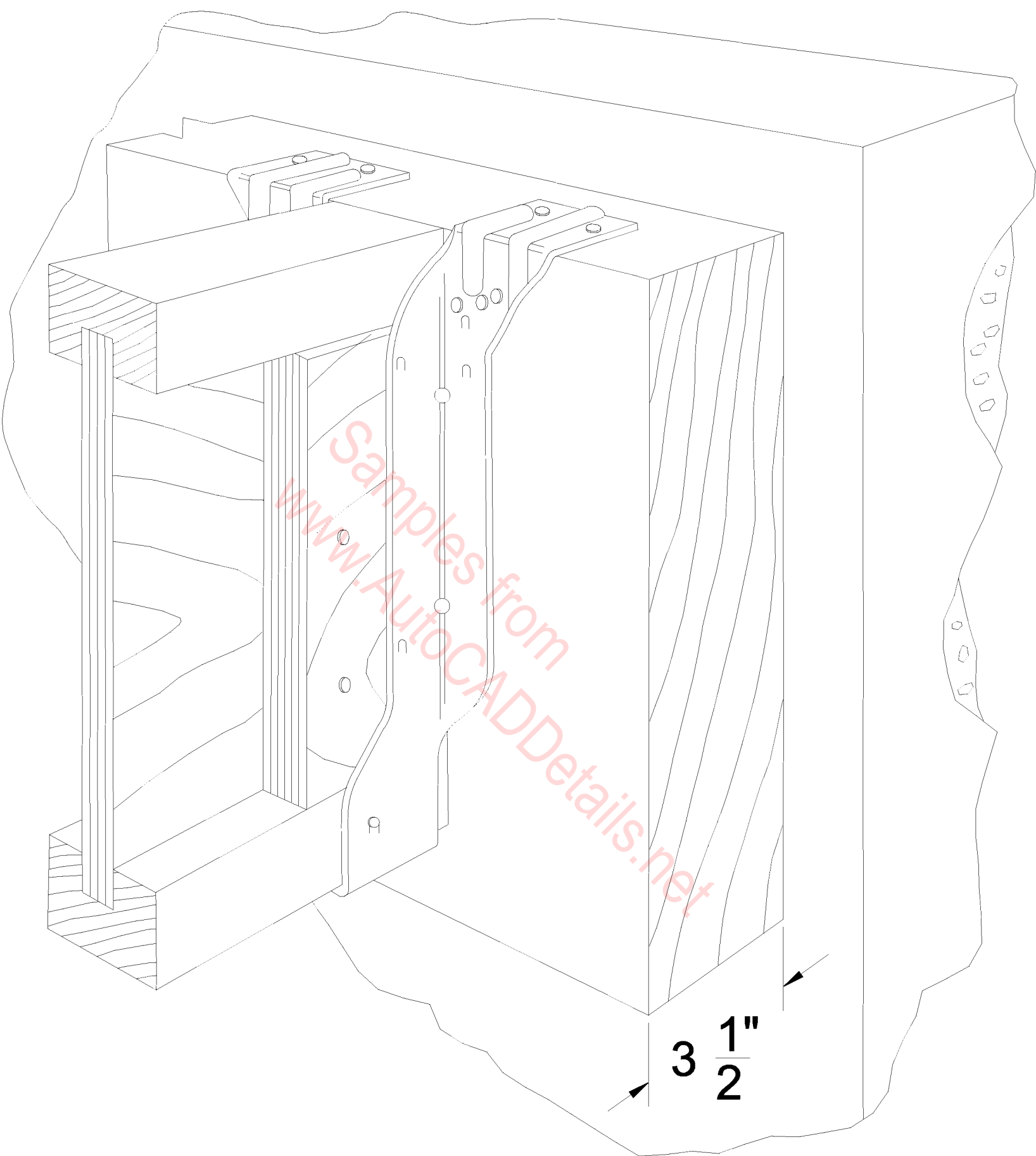

**Simpson Strong-Tie  
HIT**

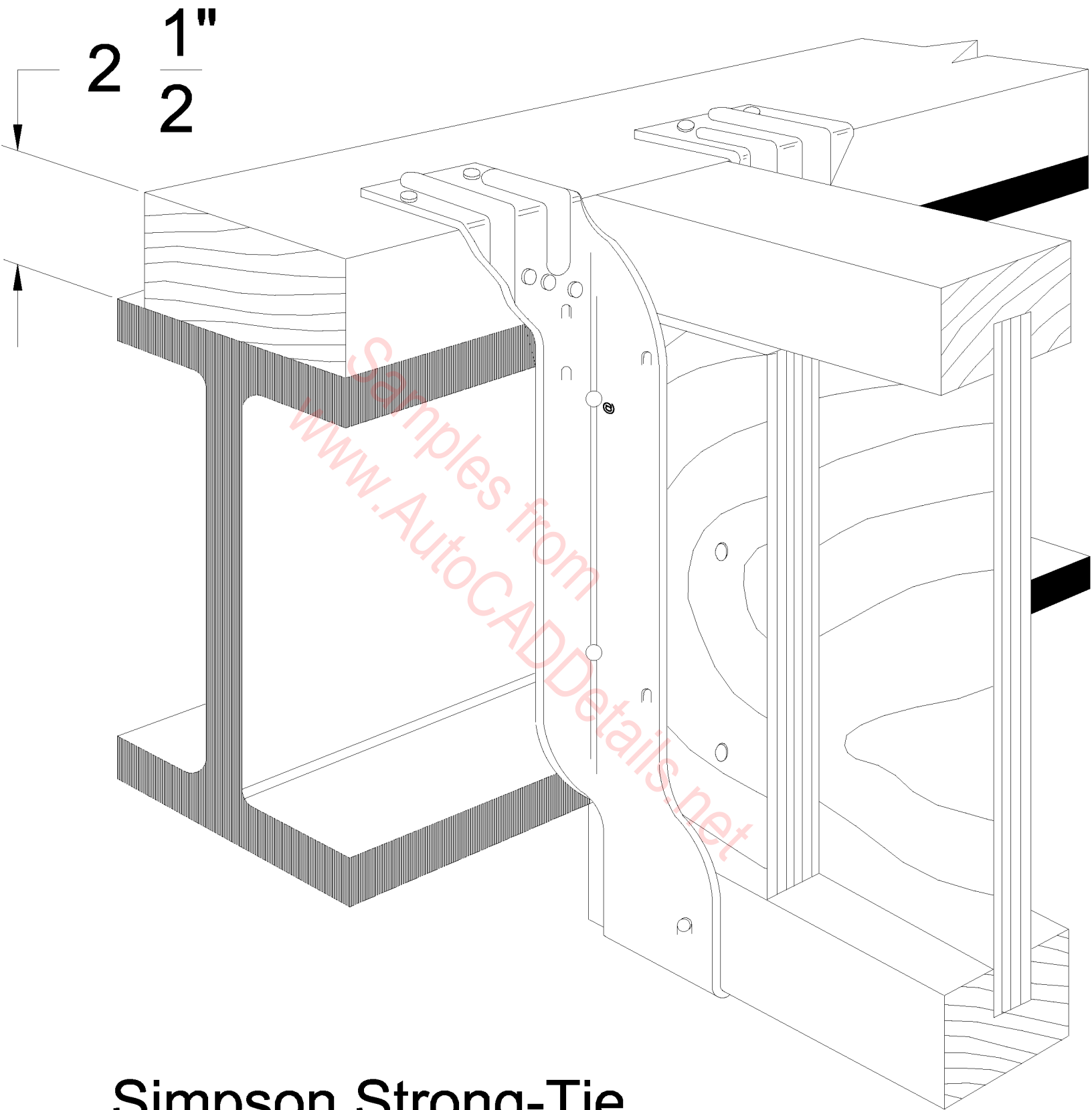

**Simpson Strong-Tie  
HIT**

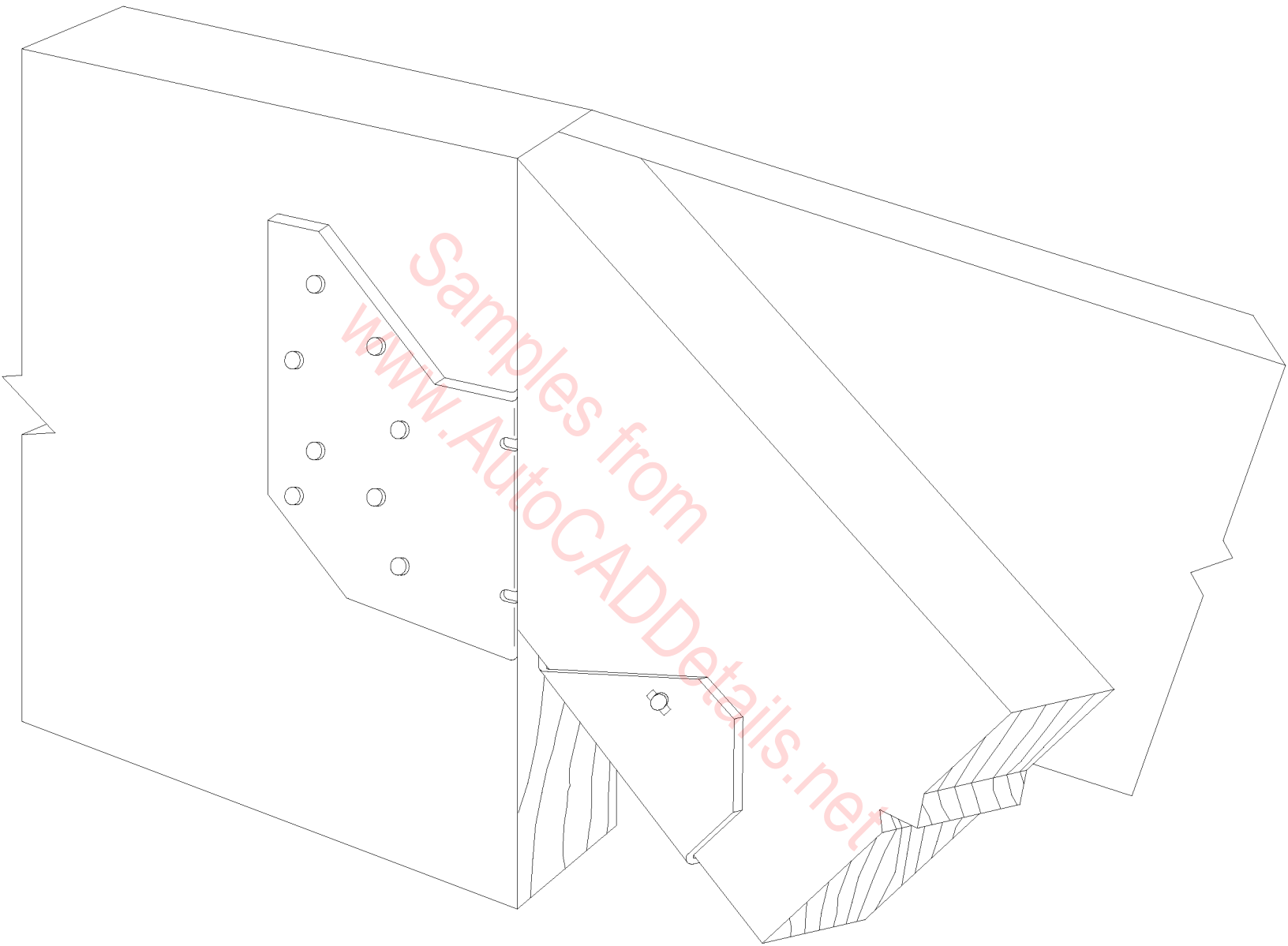

**Simpson Strong-Tie  
HRC22**

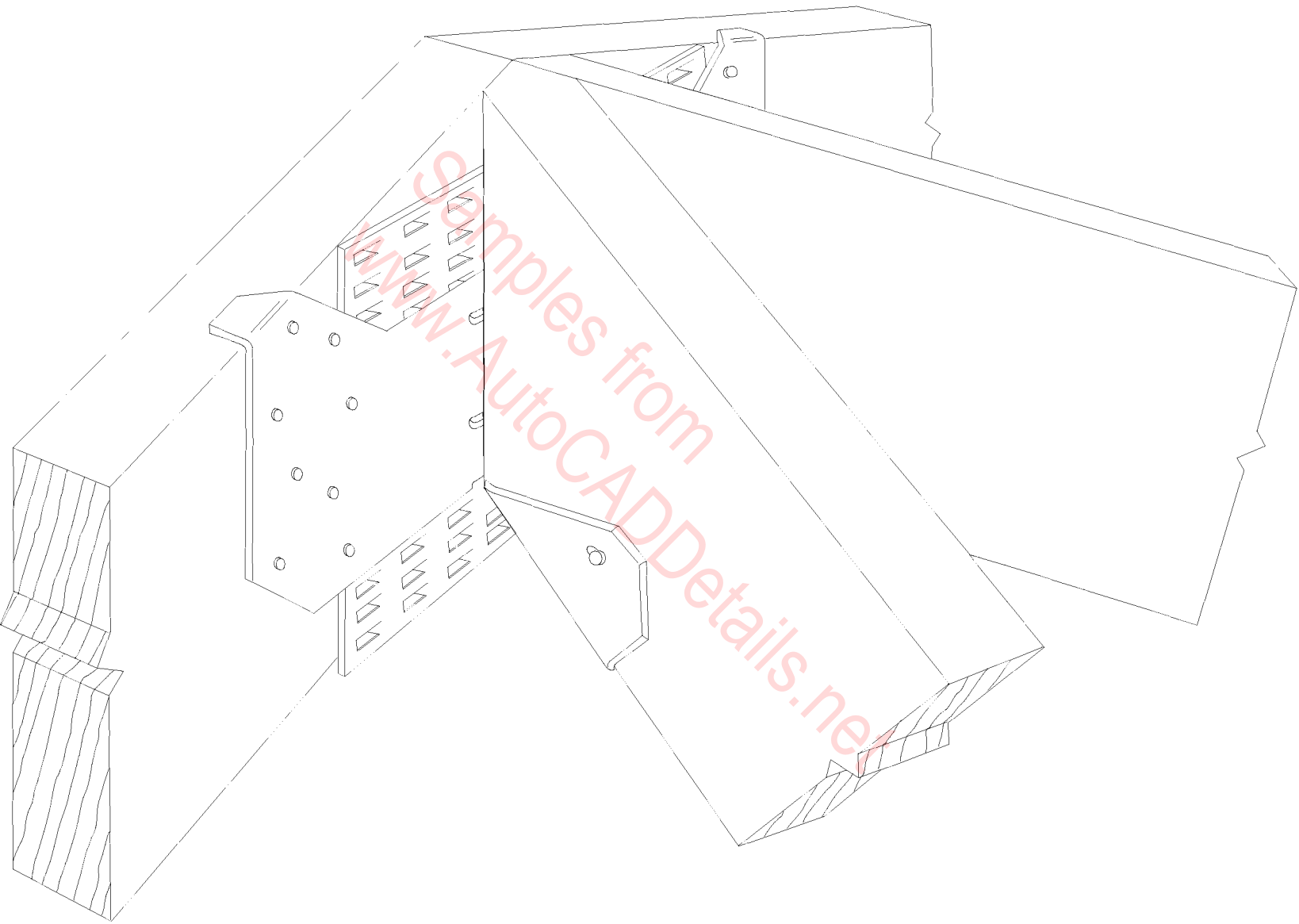



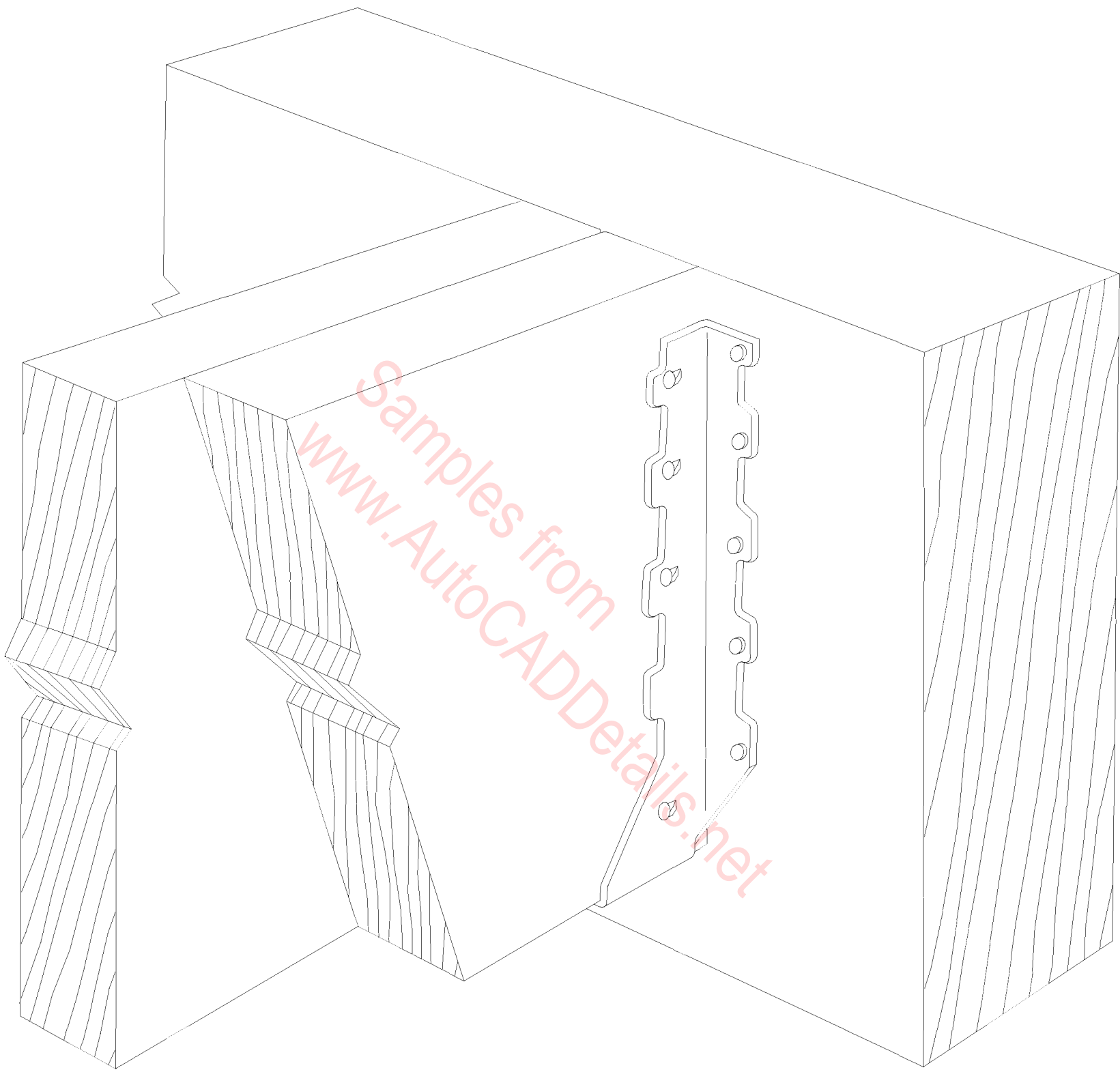

Simpson Strong-Tie  
HUS

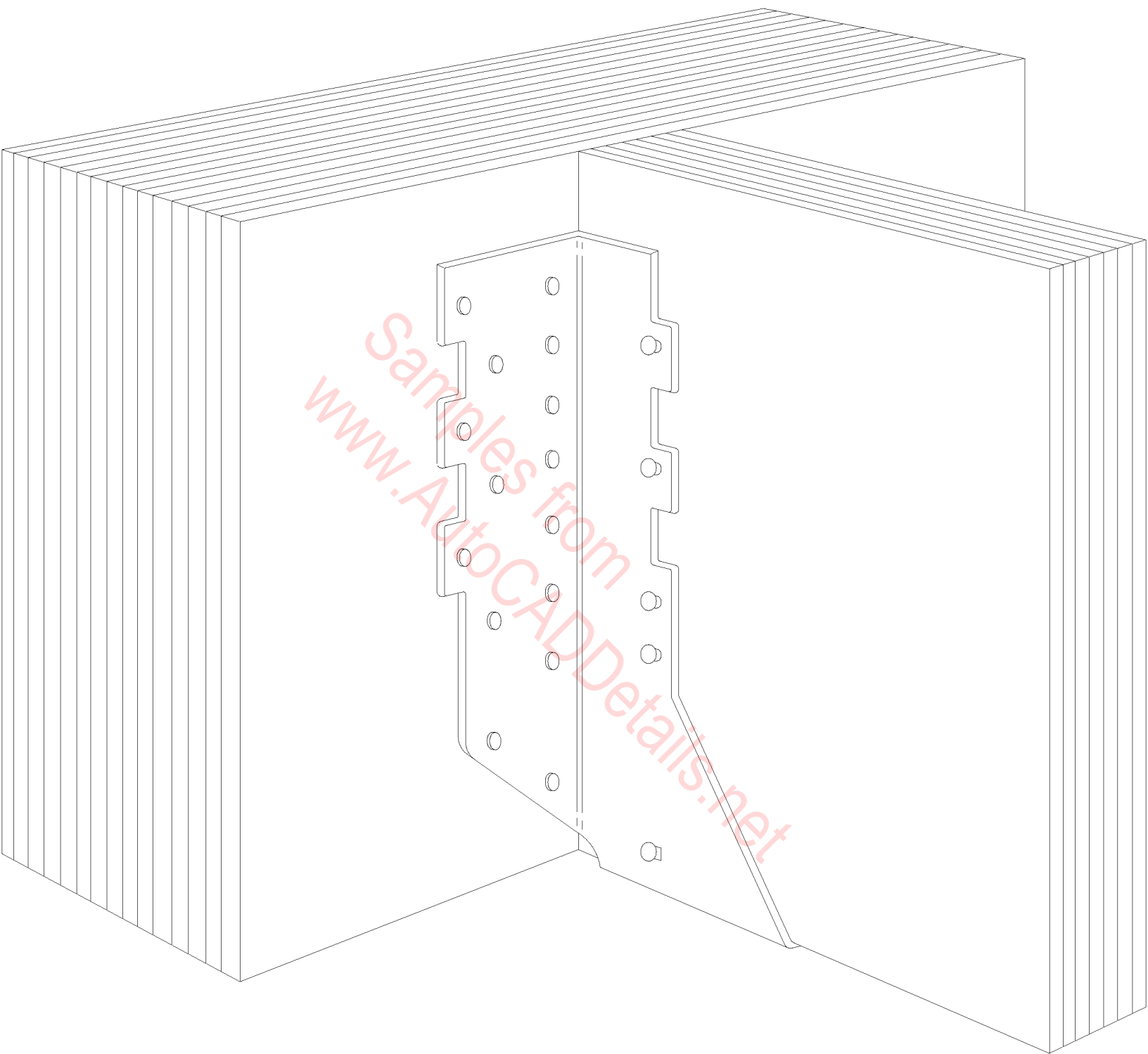

**Simpson Strong-Tie  
HUS**

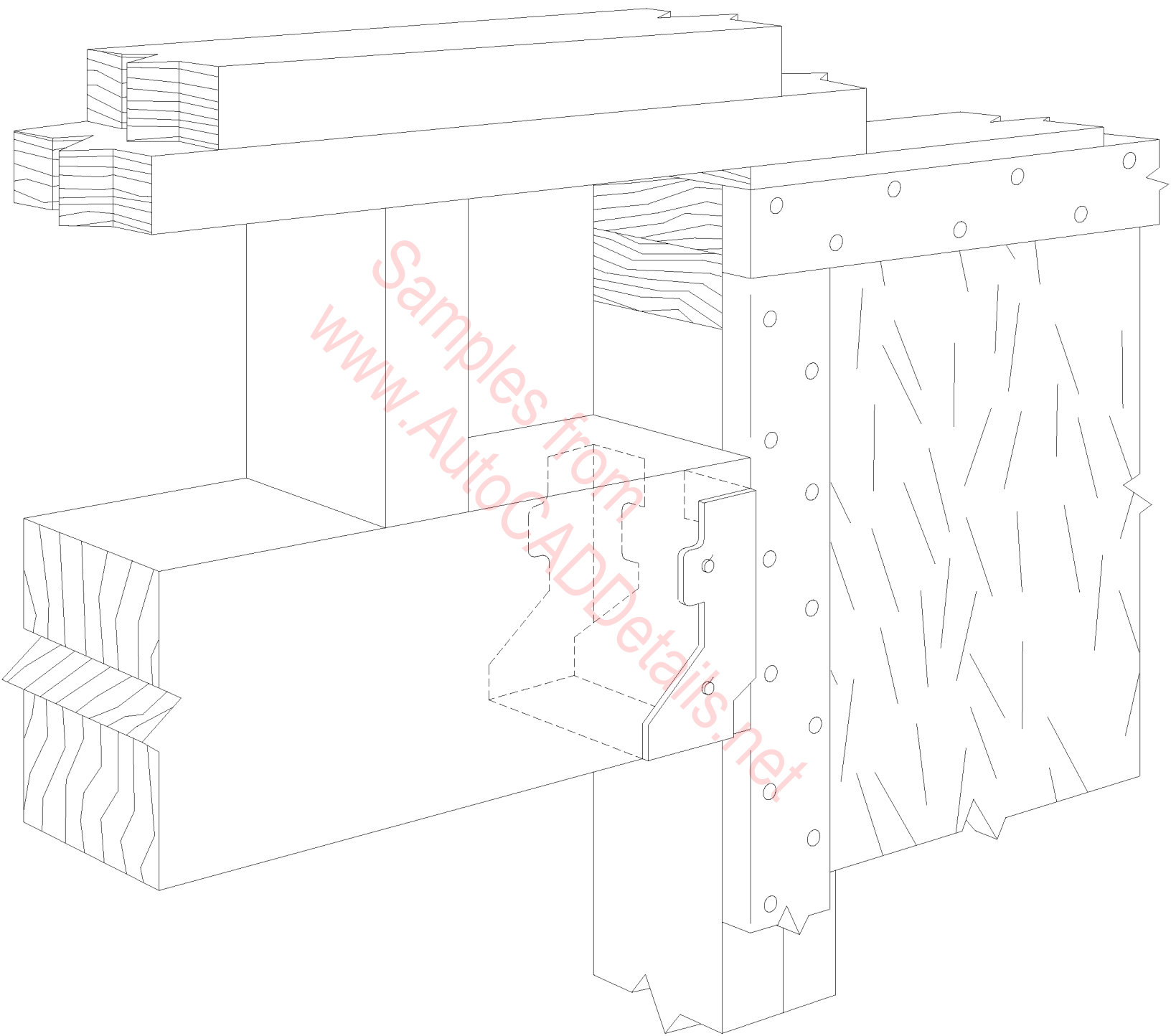

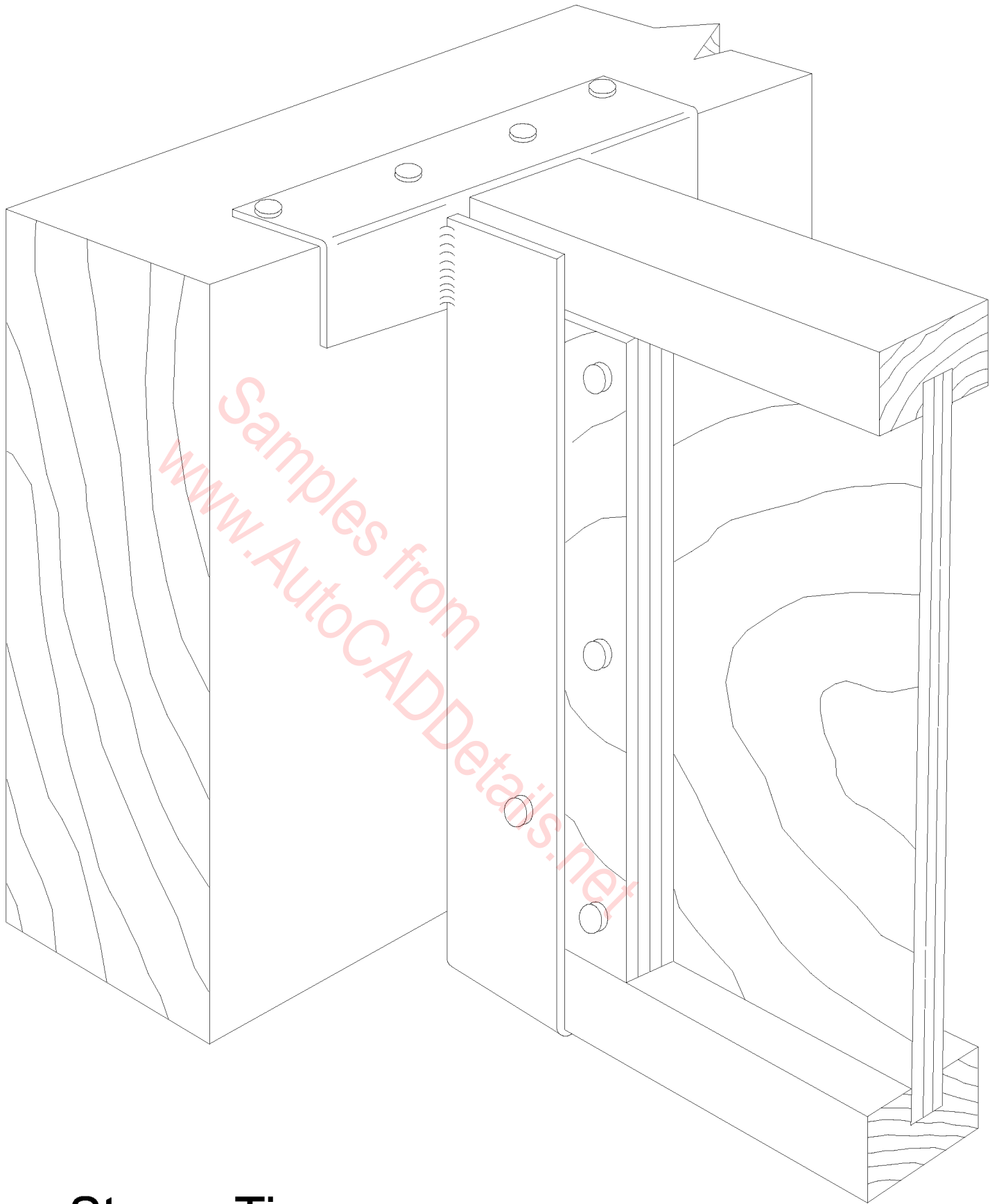

Samples from  
[www.AutoCADDetails.net](http://www.AutoCADDetails.net)

**Simpson Strong-Tie  
HW**

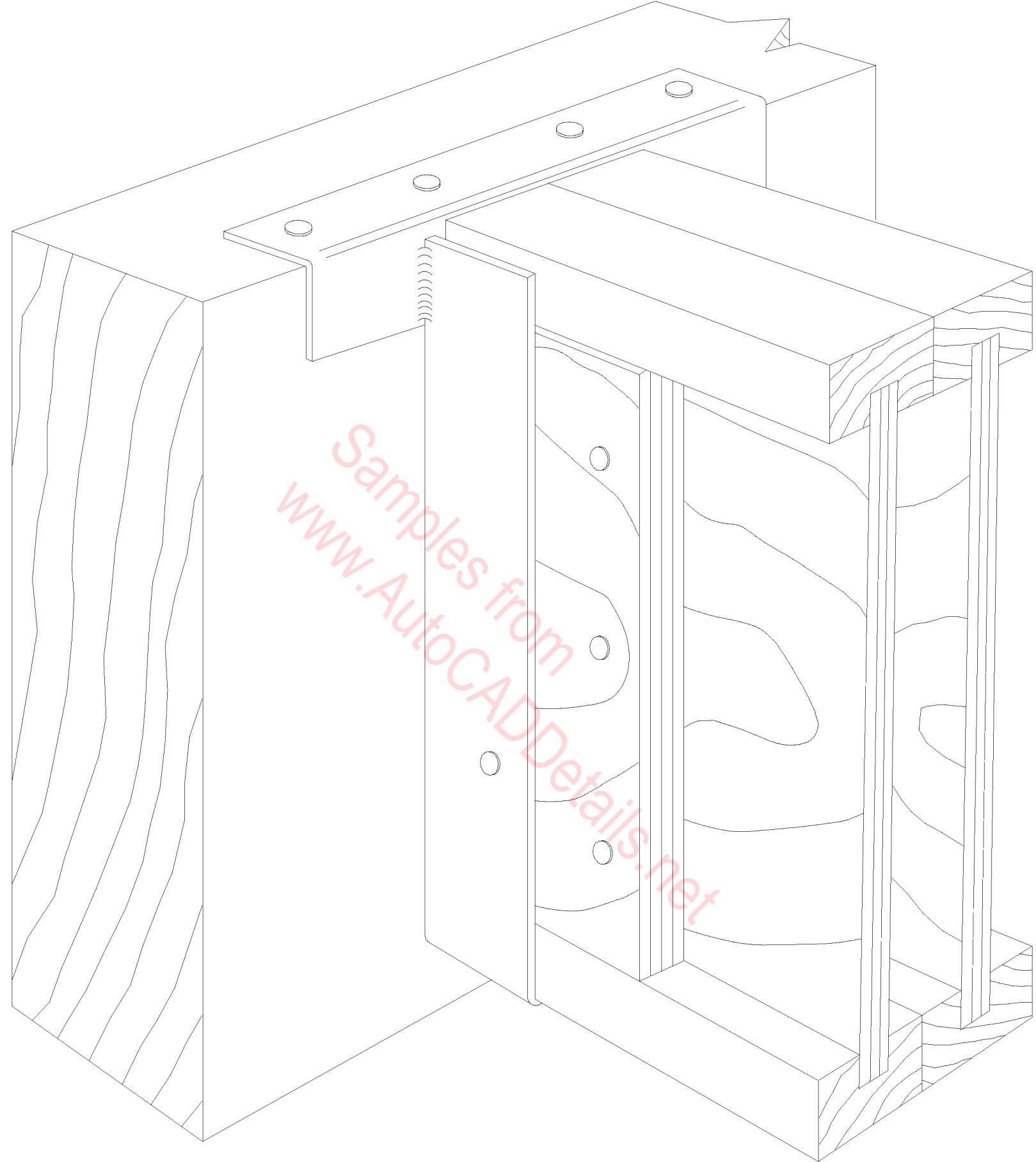

**Simpson Strong-Tie  
HW**

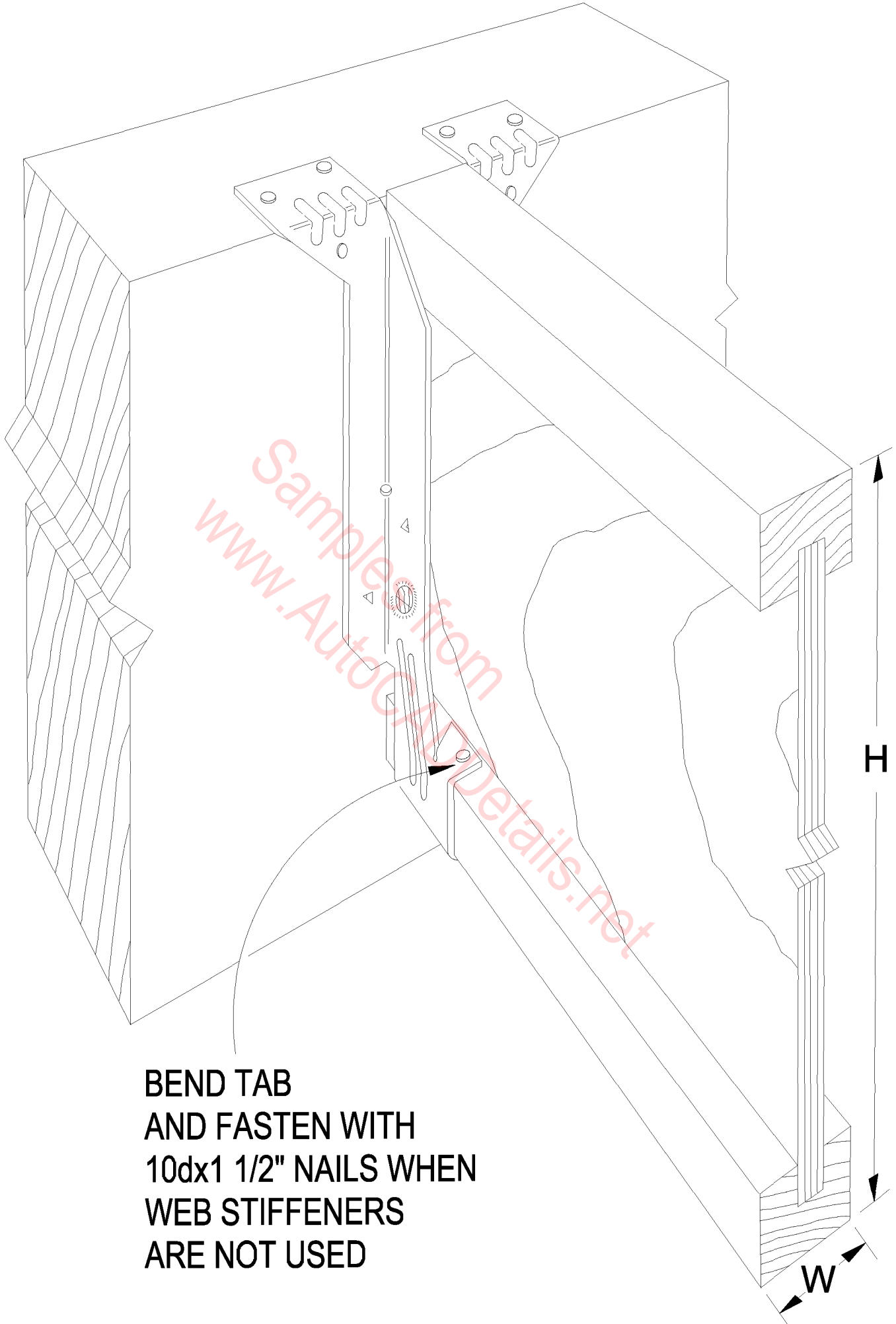

**BEND TAB  
AND FASTEN WITH  
10d x 1 1/2" NAILS WHEN  
WEB STIFFENERS  
ARE NOT USED**

**Simpson Strong-Tie  
ITT11.88**

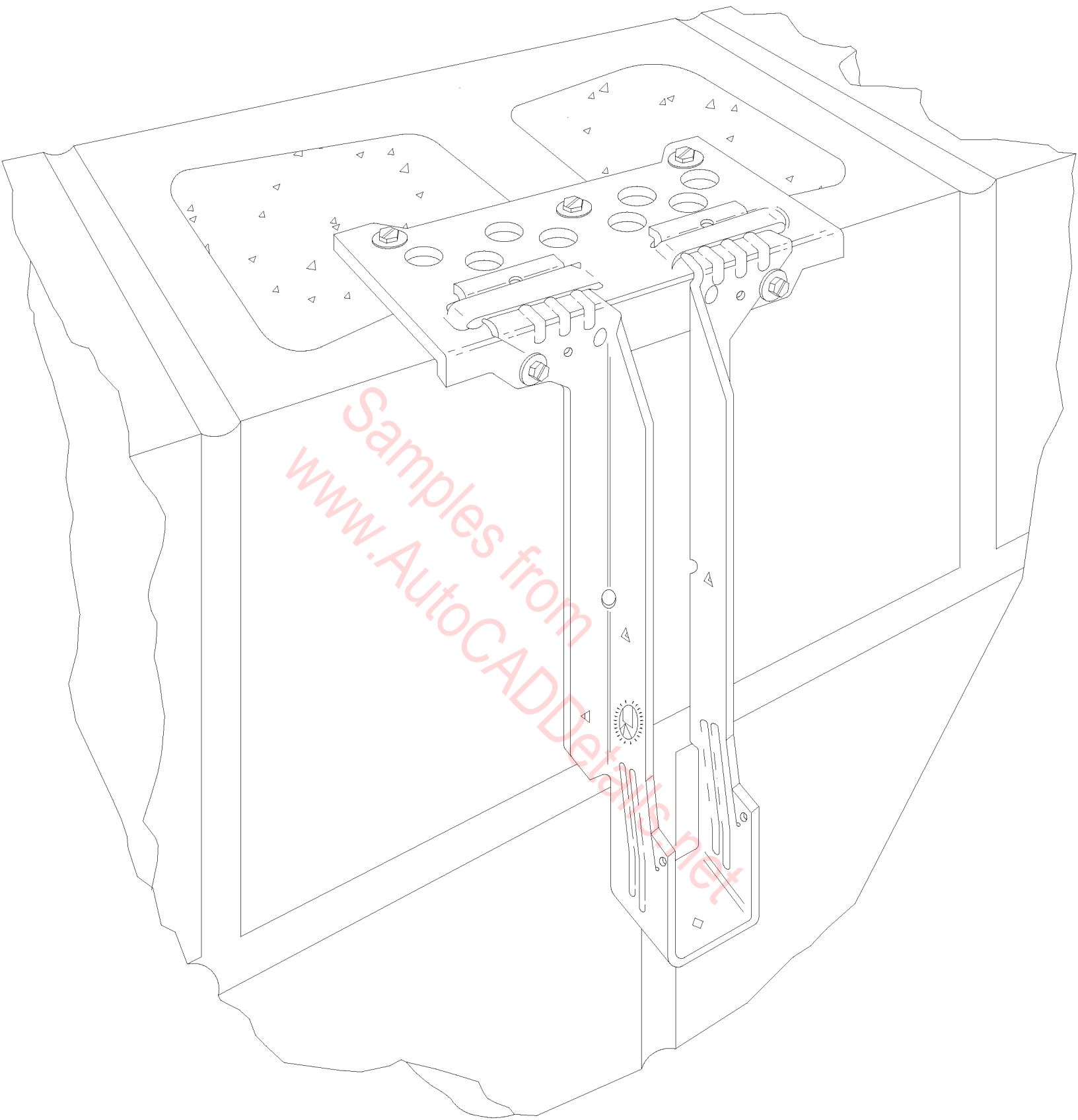

**Simpson Strong-Tie  
ITTM (on concrete blockwall)**

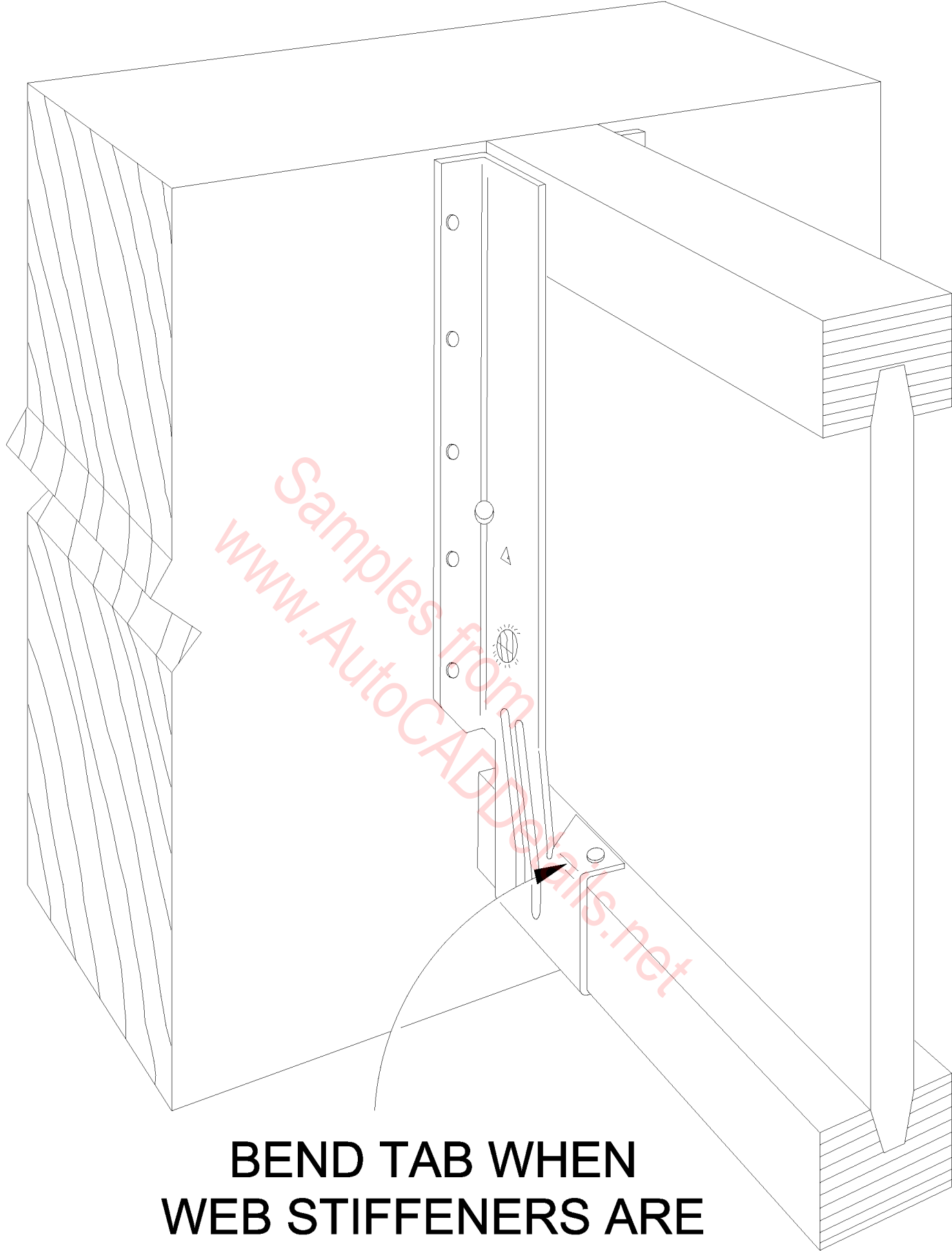

**BEND TAB WHEN  
WEB STIFFENERS ARE  
NOT USED.**

**Simpson Strong-Tie  
IUT11**



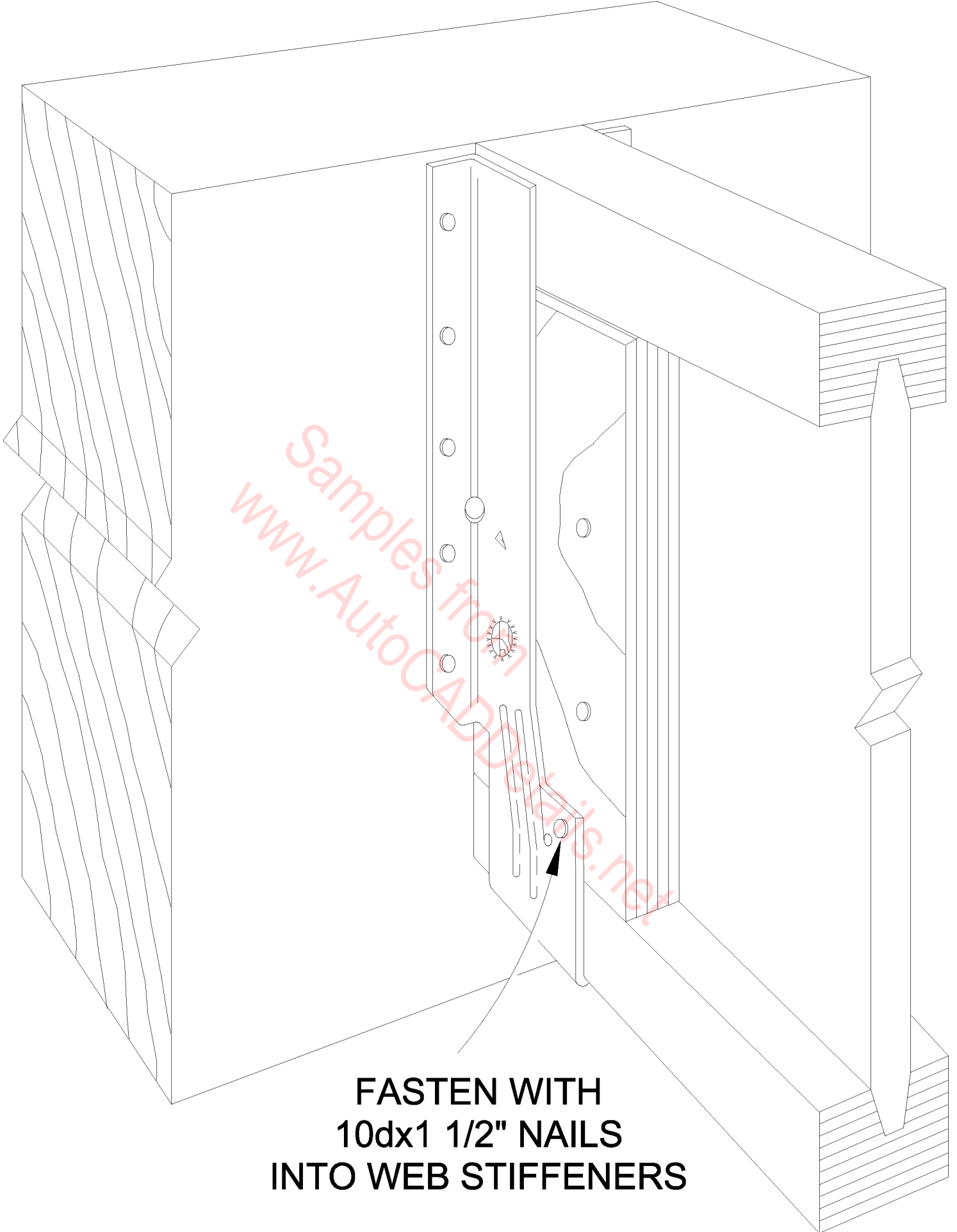

**FASTEN WITH  
10dx1 1/2" NAILS  
INTO WEB STIFFENERS**

**Simpson Strong-Tie  
IUT11 (with web stiffener)**

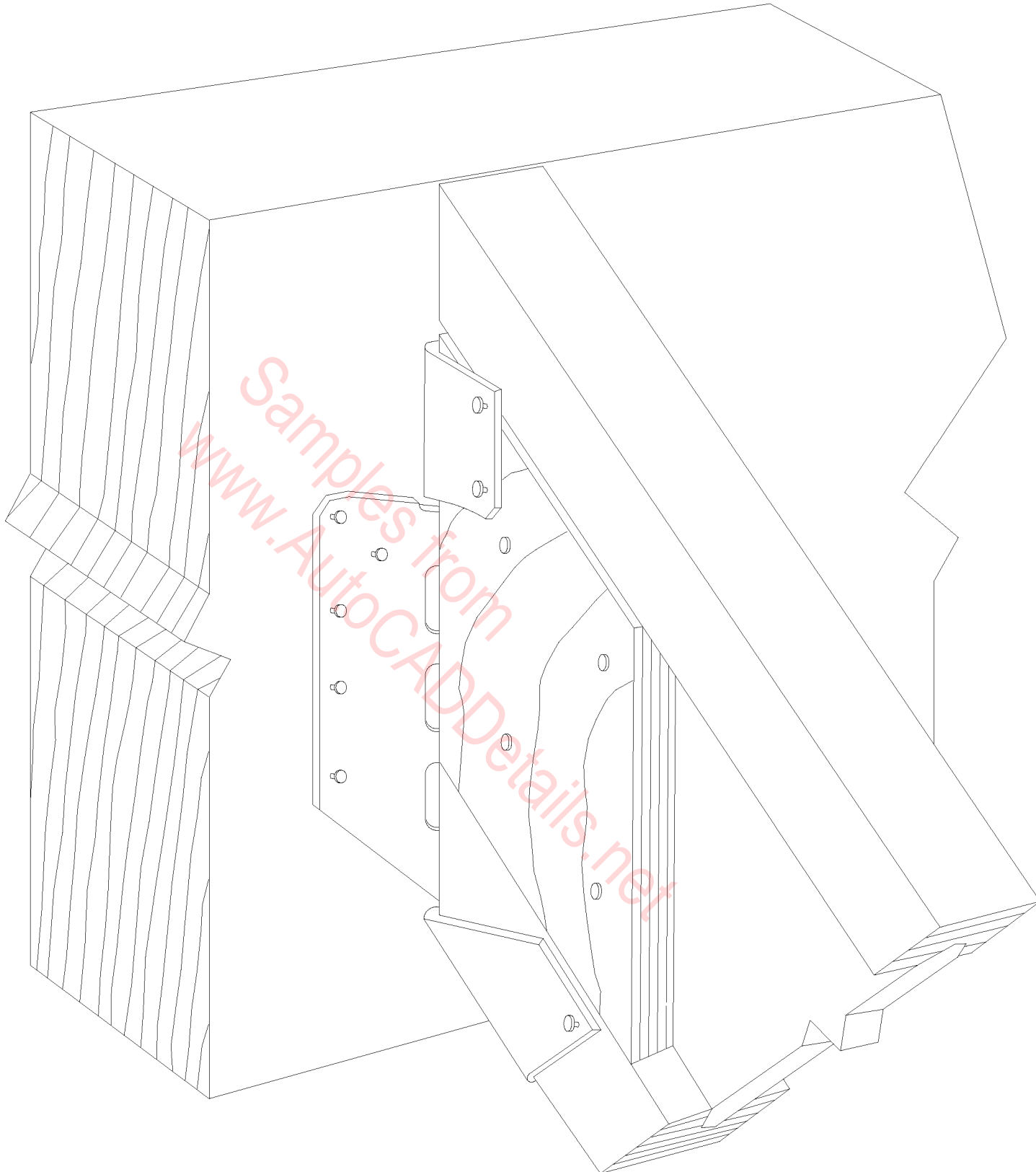

**Simpson Strong-Tie  
LSSU**

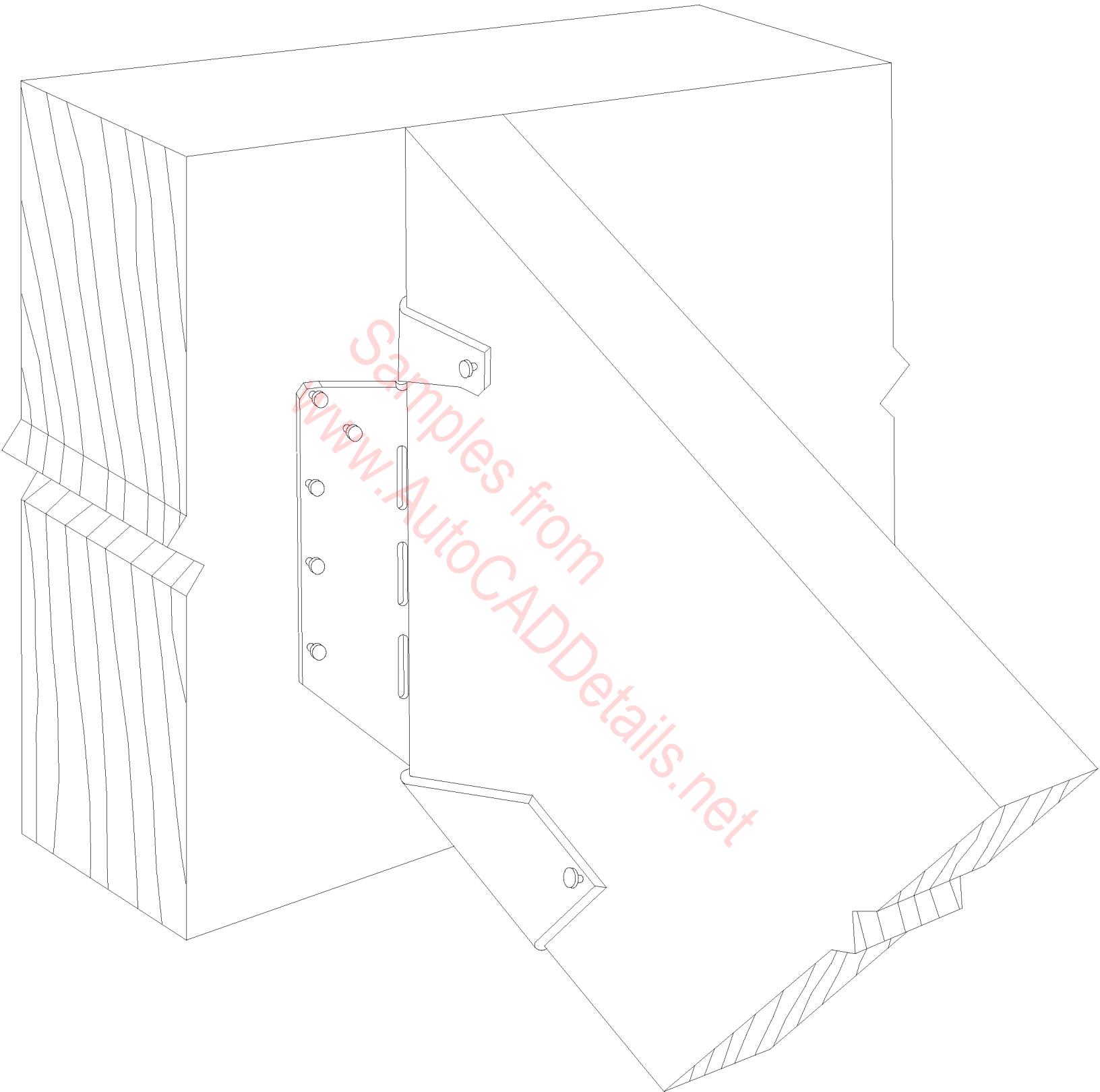

Simpson Strong-Tie  
LSSU28

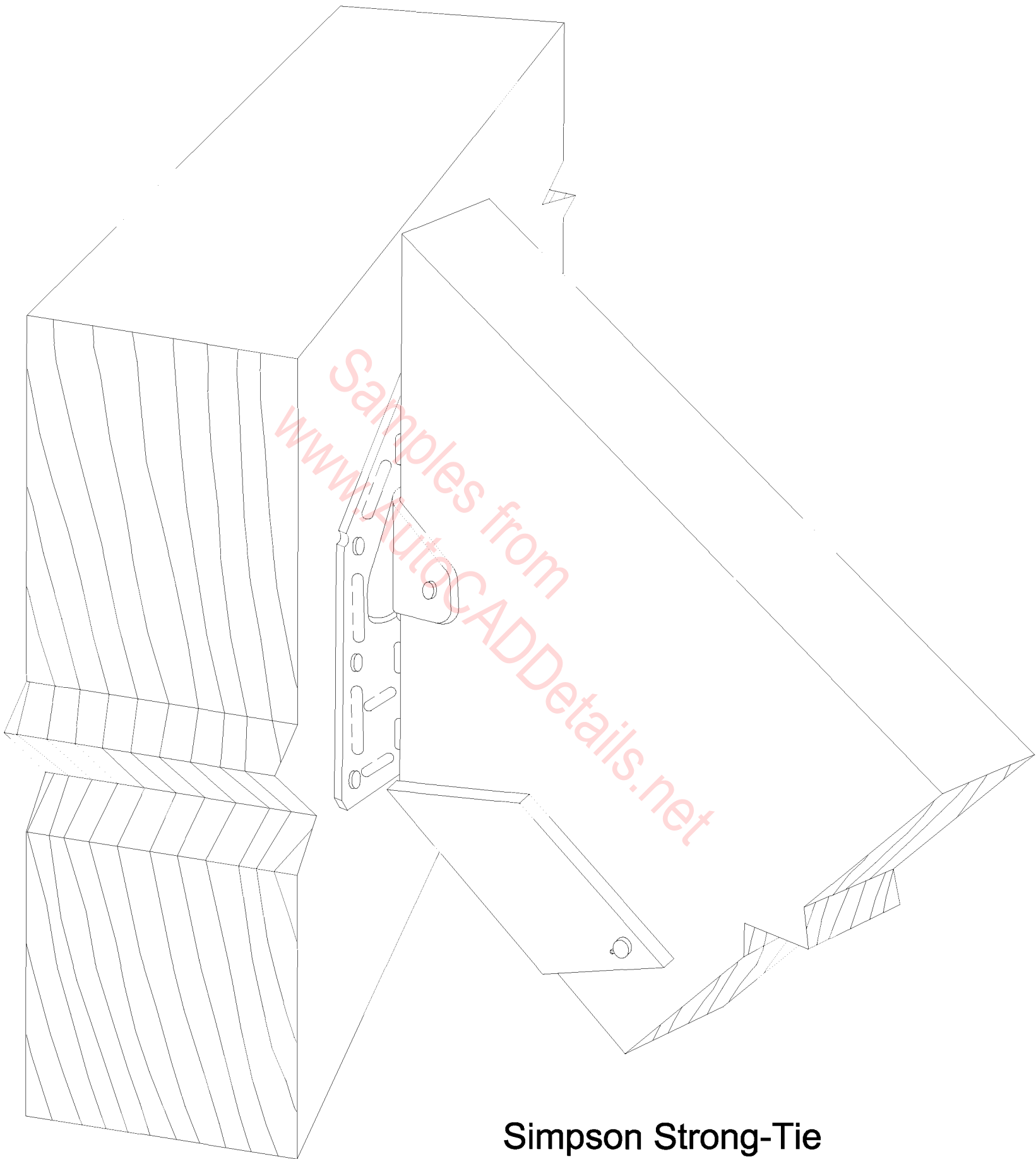

Samples from  
[www.AutoCADDetails.net](http://www.AutoCADDetails.net)

**Simpson Strong-Tie  
LSU26**

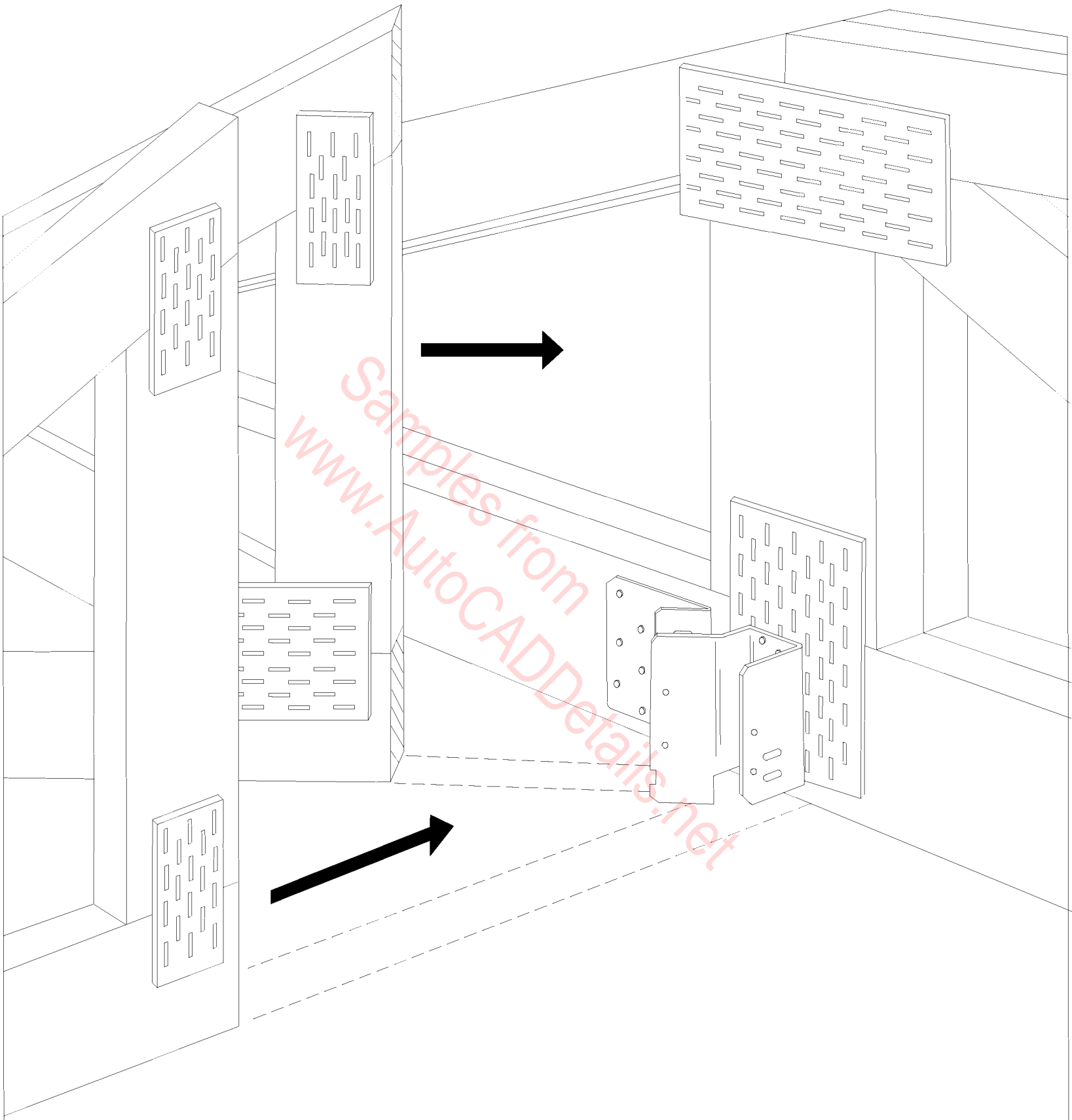

**Simpson Strong-Tie  
LTHJL**



**NO  
JOIST  
NAILING  
REQUIRED**

**Simpson Strong-Tie  
LUP**

Samples from  
[www.AutocADDetails.net](http://www.AutocADDetails.net)

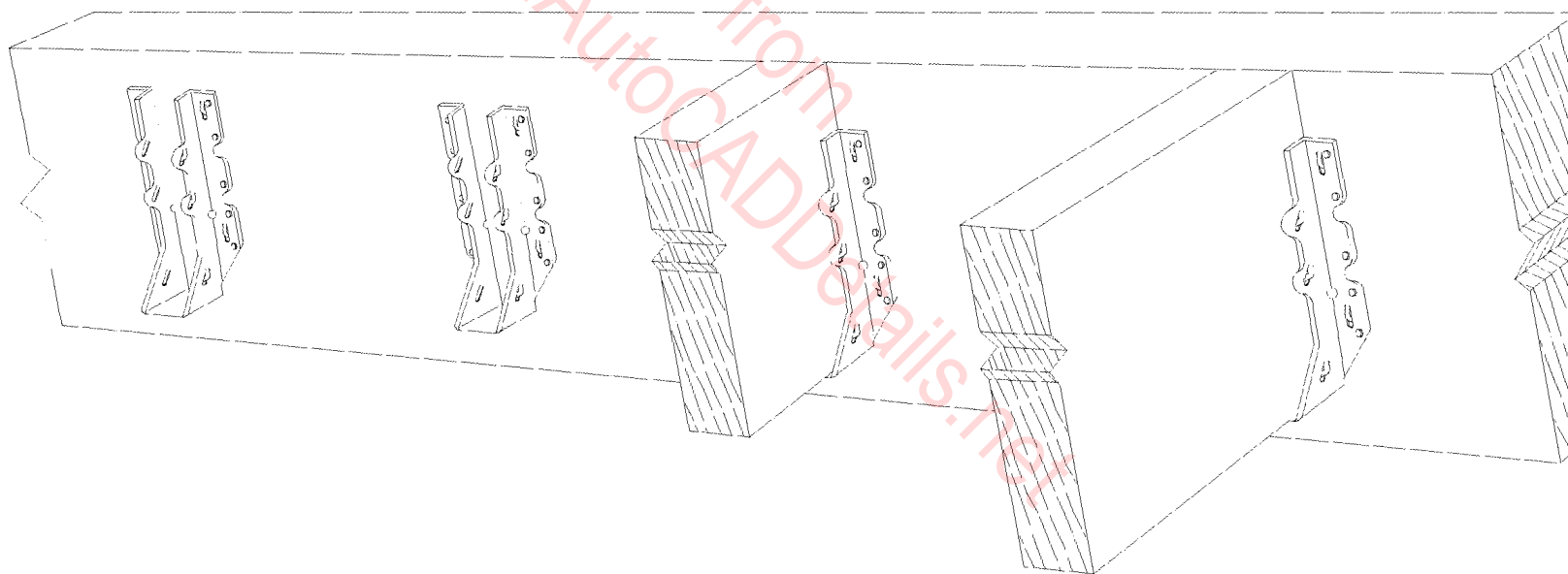

Simpson Strong-Tie  
LUP210

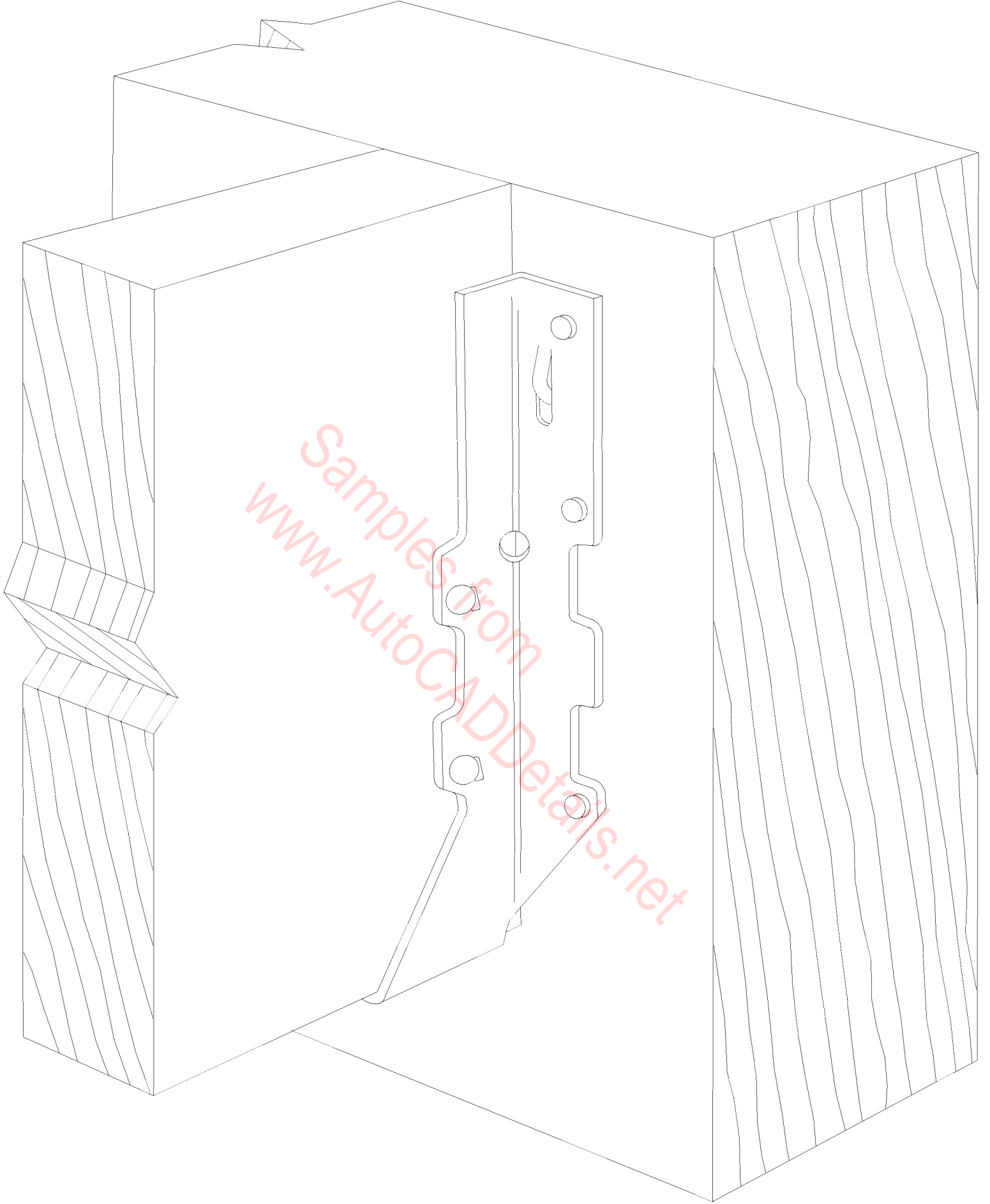

Simpson Strong-Tie  
**LUS28**



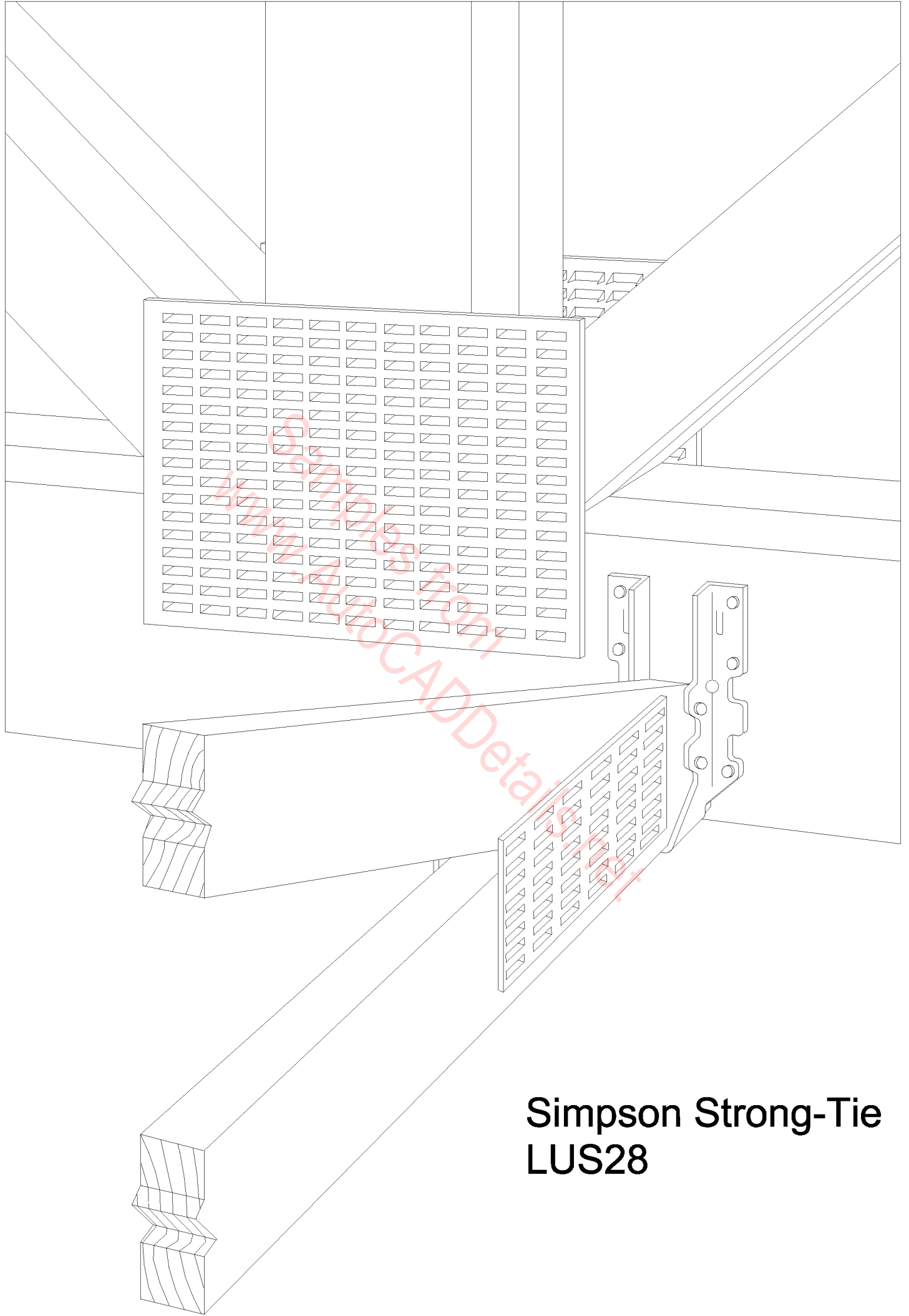

**Simpson Strong-Tie  
LUS28**

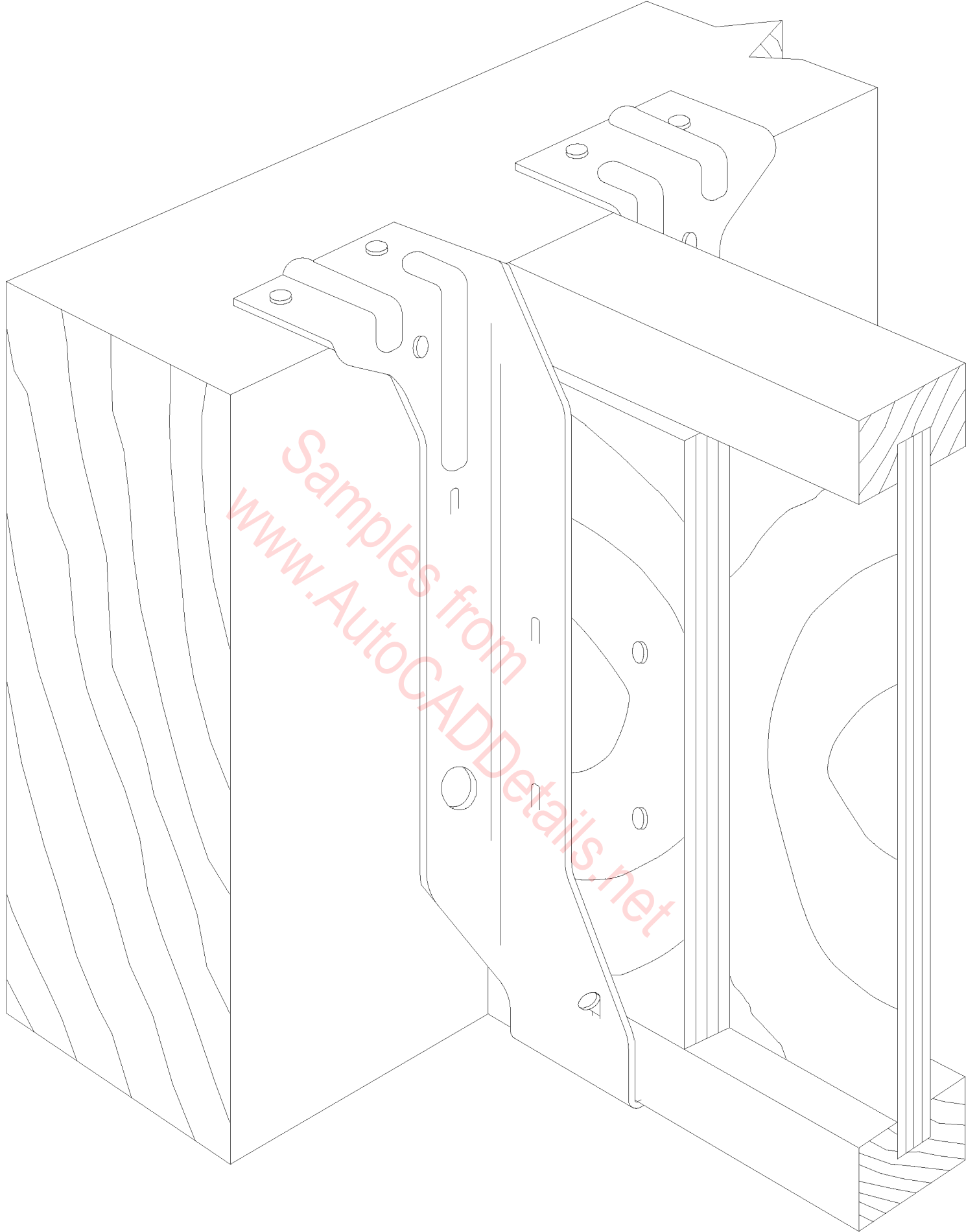

**Simpson Strong-Tie  
MIT**

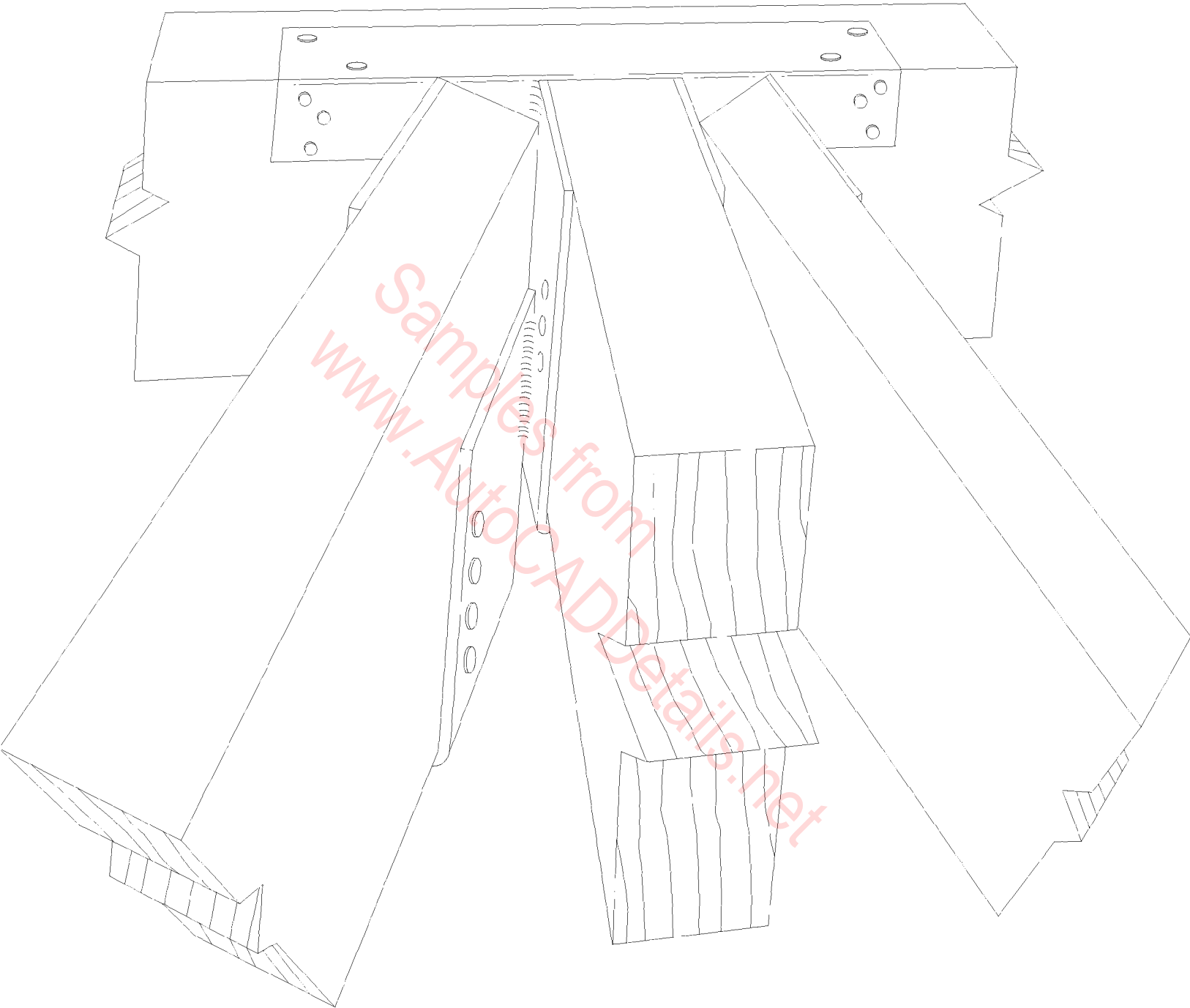

**Simpson Strong-Tie  
MSC410**

---

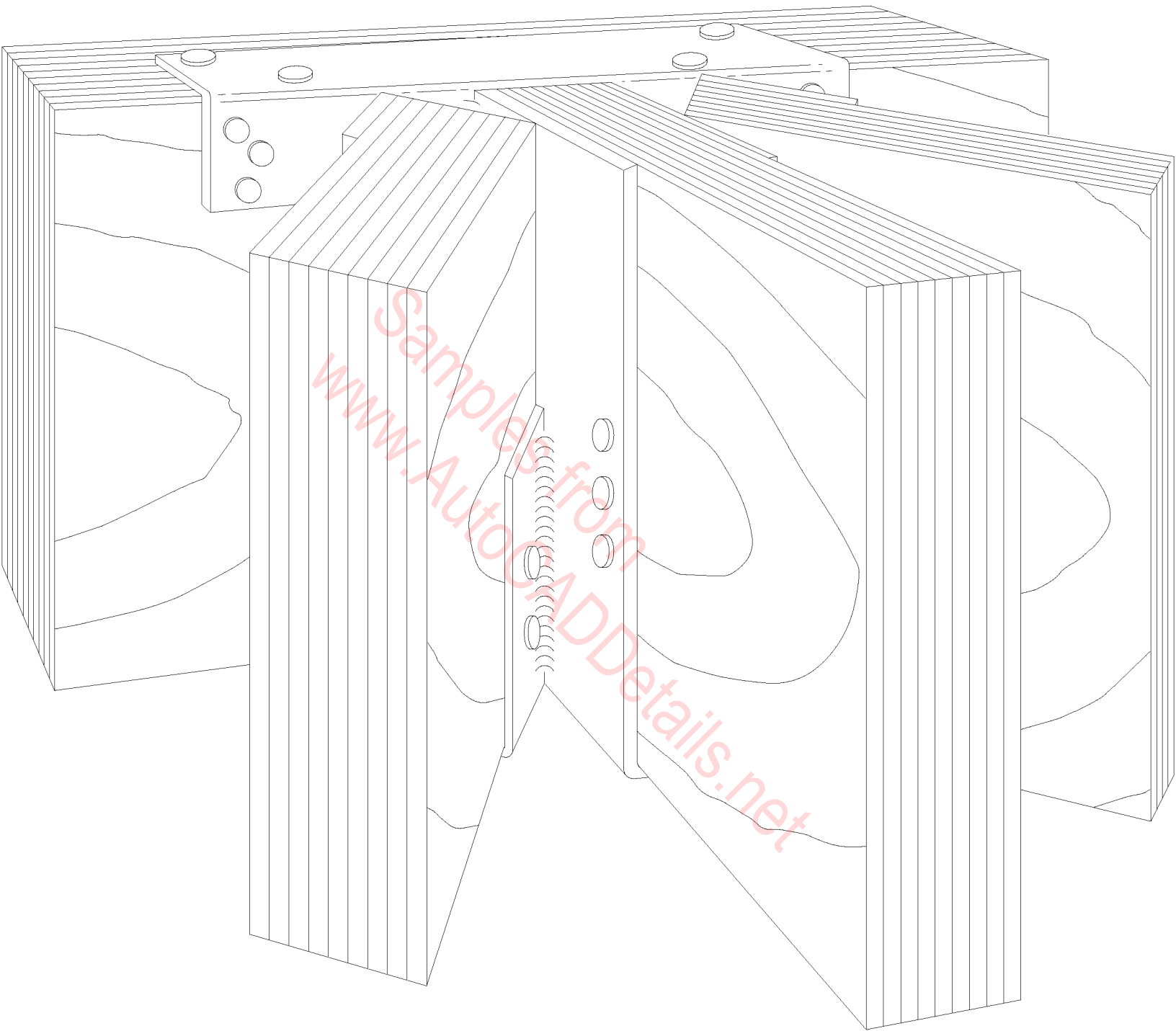

**Simpson Strong-Tie  
MSC9**

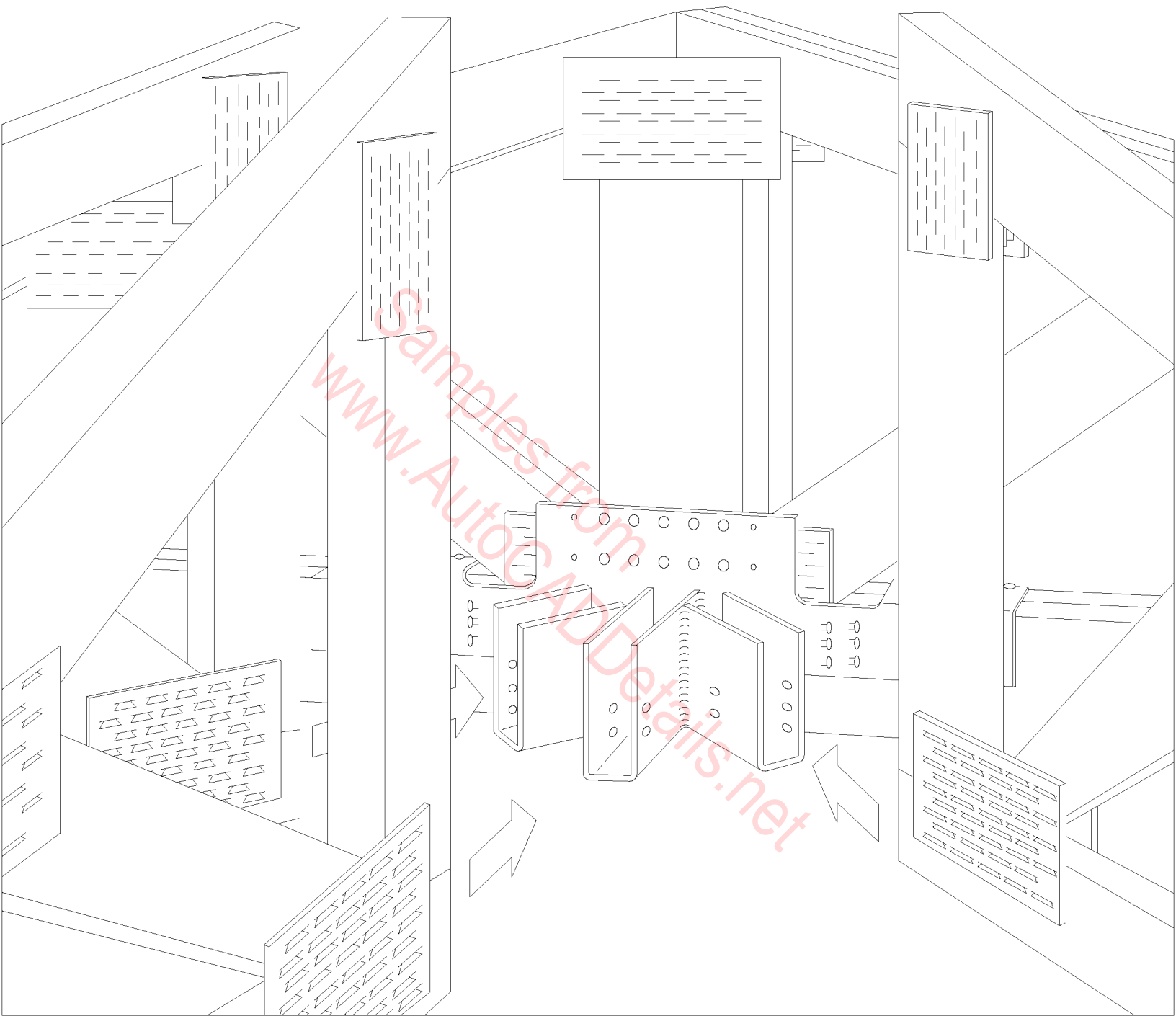

**Simpson Strong-Tie  
MSCPT2**

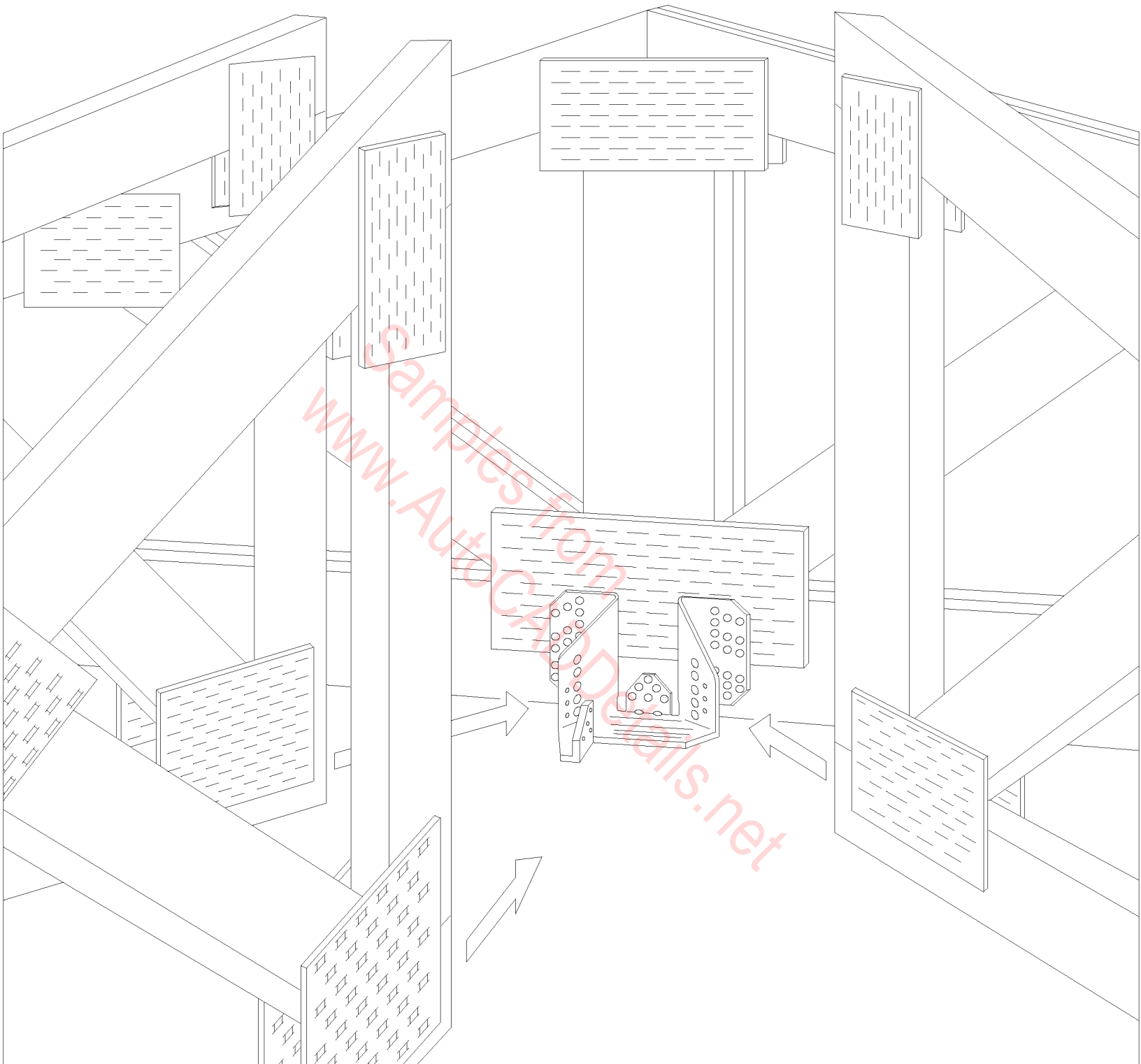

**Simpson Strong-Tie  
MTHM**

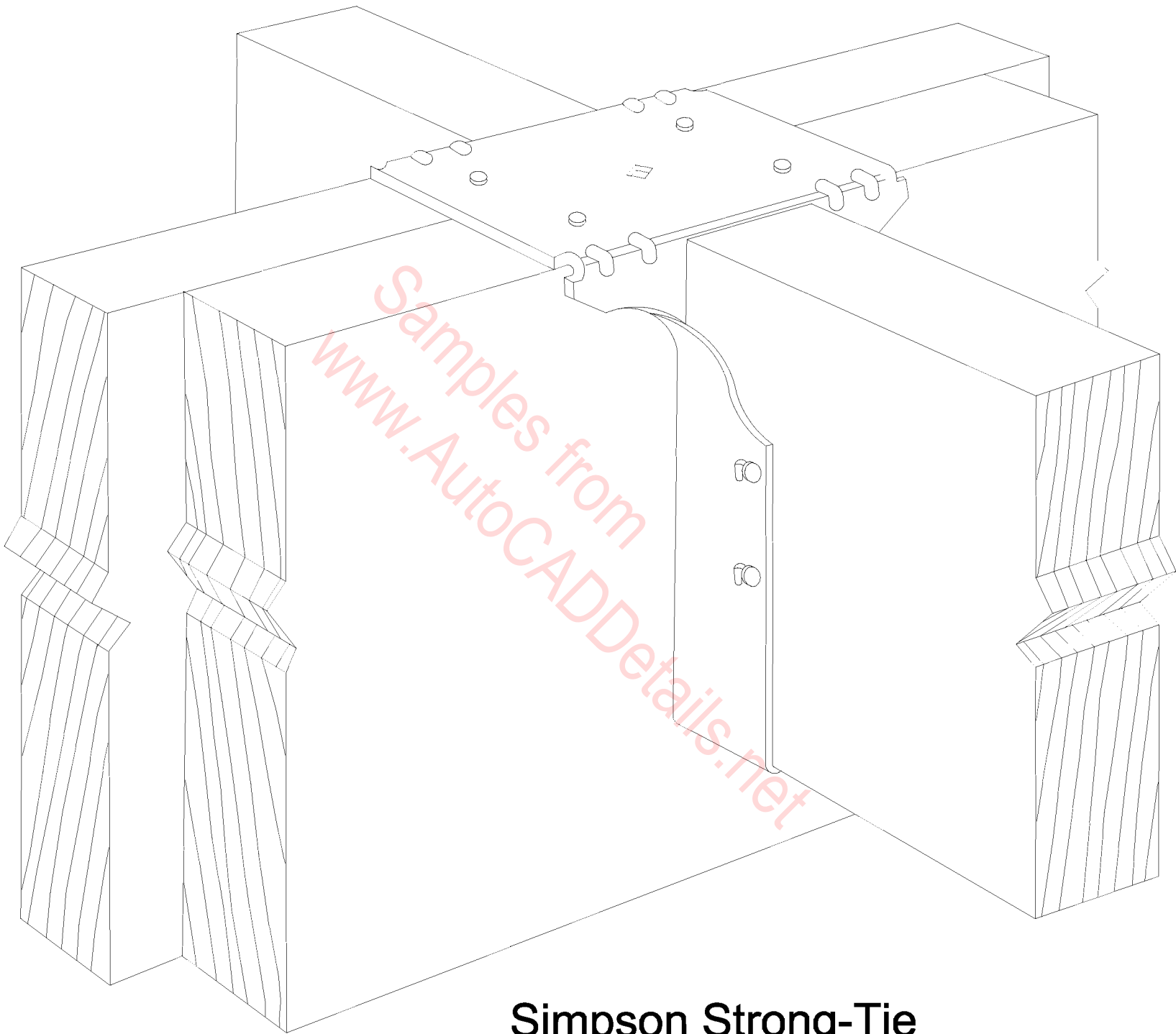

**Simpson Strong-Tie  
PFDS26**

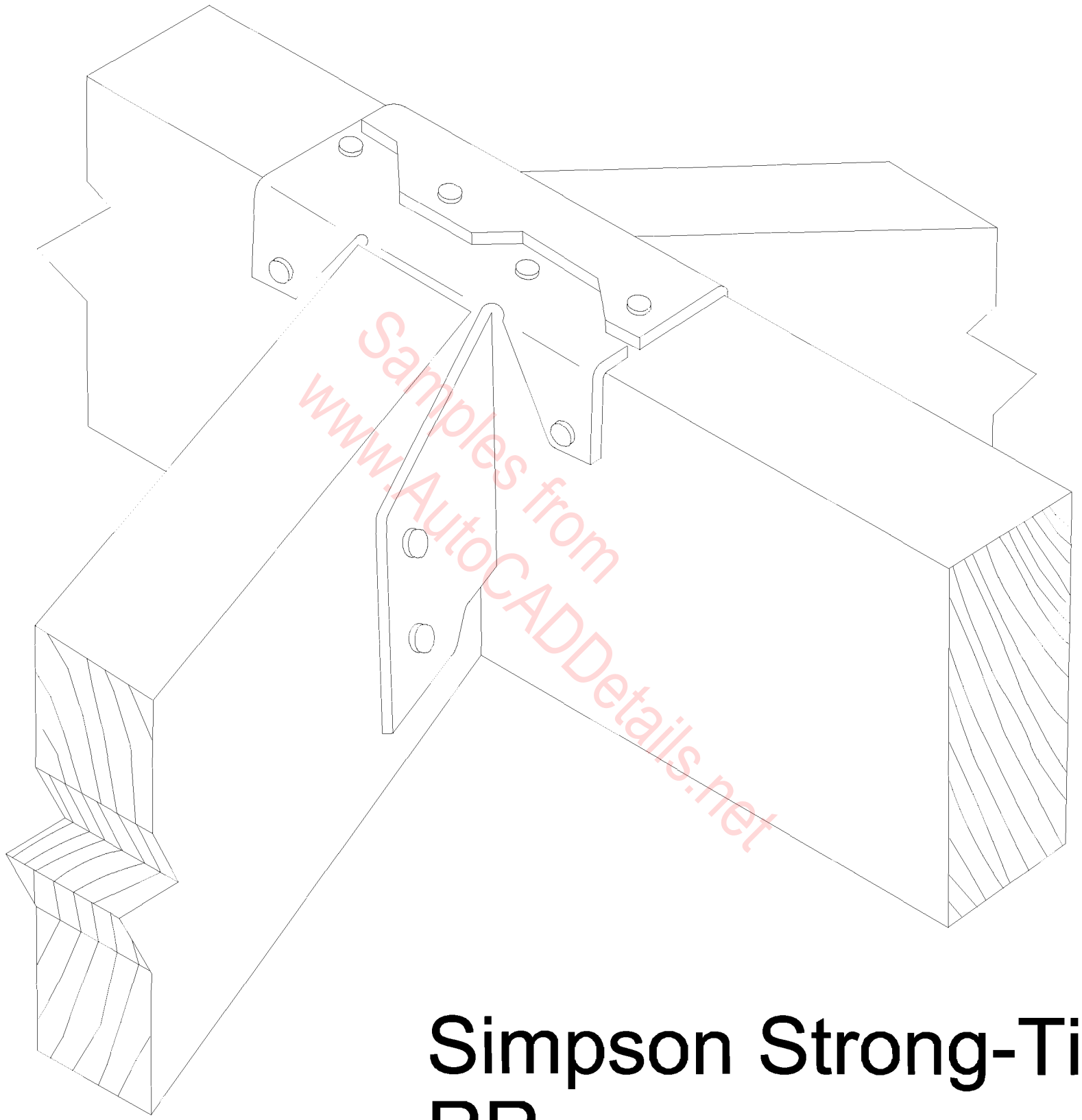

Samples from  
[www.AutoCADDetails.net](http://www.AutoCADDetails.net)

# Simpson Strong-Tie RR



**4 Top Nails- Typical THA  
Minimum Nailing Configuration**

**2 Face Nails  
(4 Face Nails  
for THA29)**

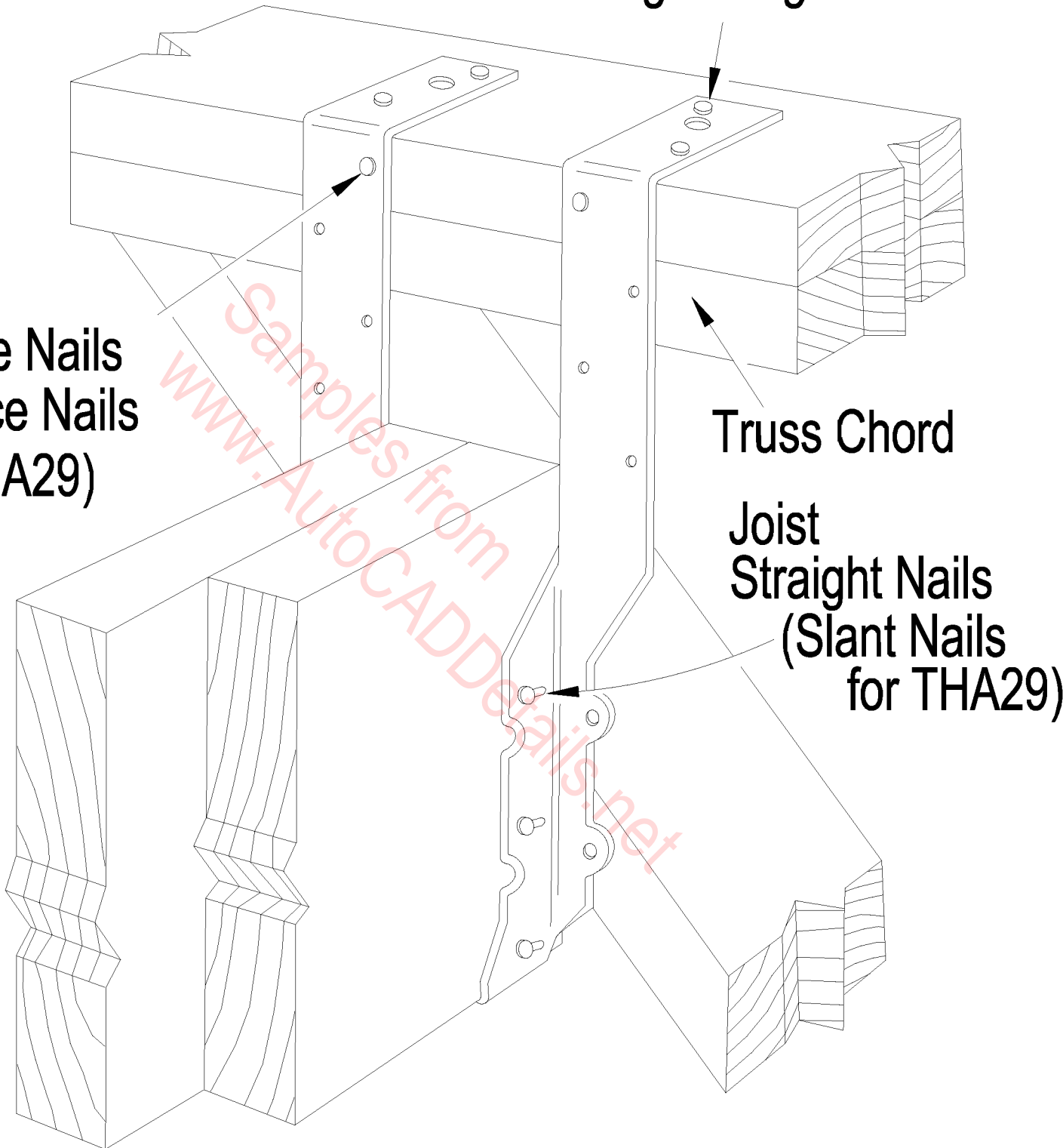

**Simpson Strong-Tie  
THA**

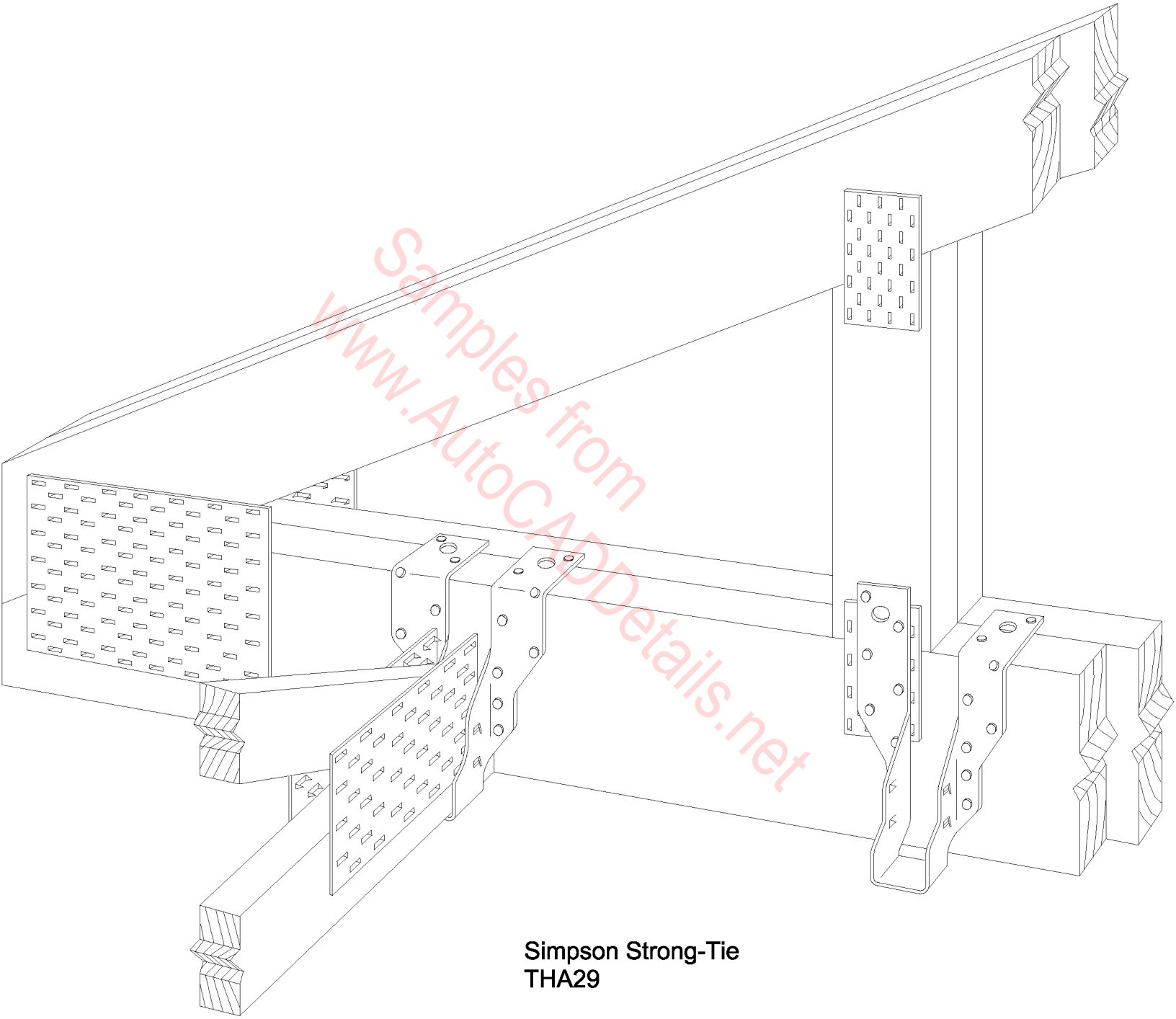

**Simpson Strong-Tie  
THA29**

**MINIMUM OF 2 1/2" OF  
TOP FLANGE MATERIAL FOR  
MIN. NAILING CONFIGURATION**

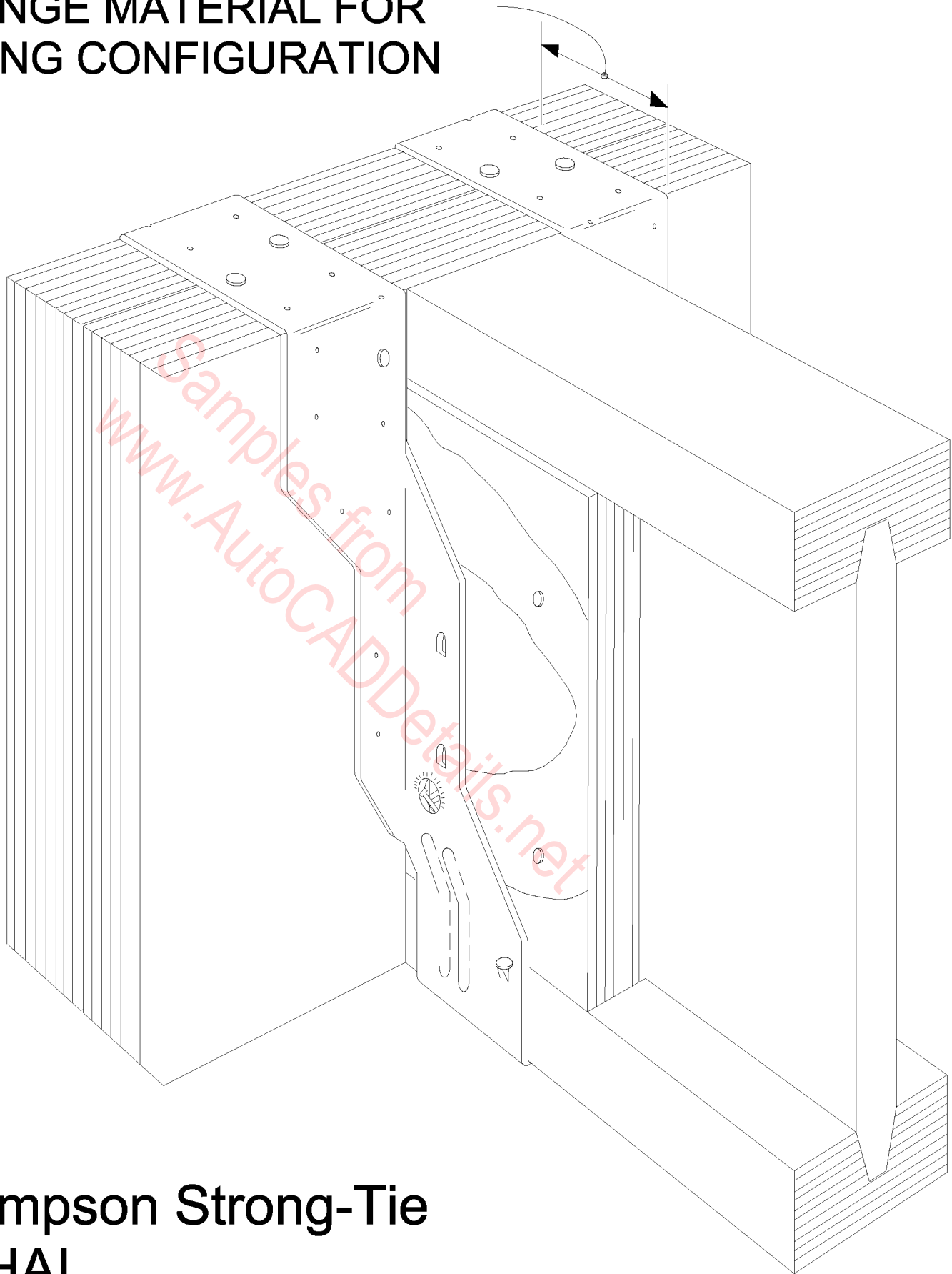

**Simpson Strong-Tie  
THAI**

**MINIMUM OF 2 1/2" OF  
TOP FLANGE MATERIAL FOR  
MIN. NAILING CONFIGURATION**

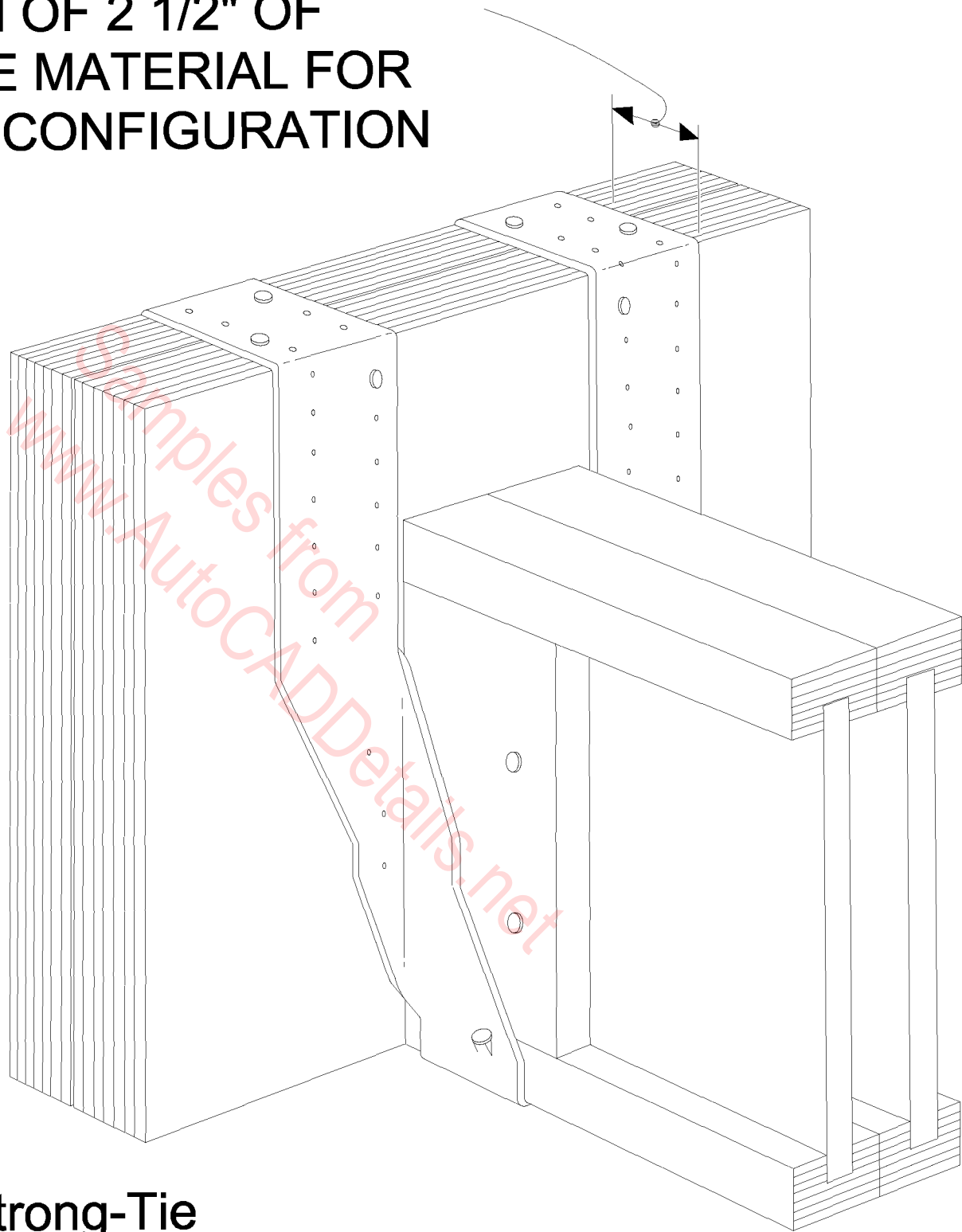

**Simpson Strong-Tie  
THAI-2**

4 TOP NAILS-TYPICAL THA  
MINIMUM NAIL CONFIGURATION

2  
FACE  
NAILS

JOIST STRAIGHT NAILS

Simpson Strong-Tie  
THA (on I-beam)

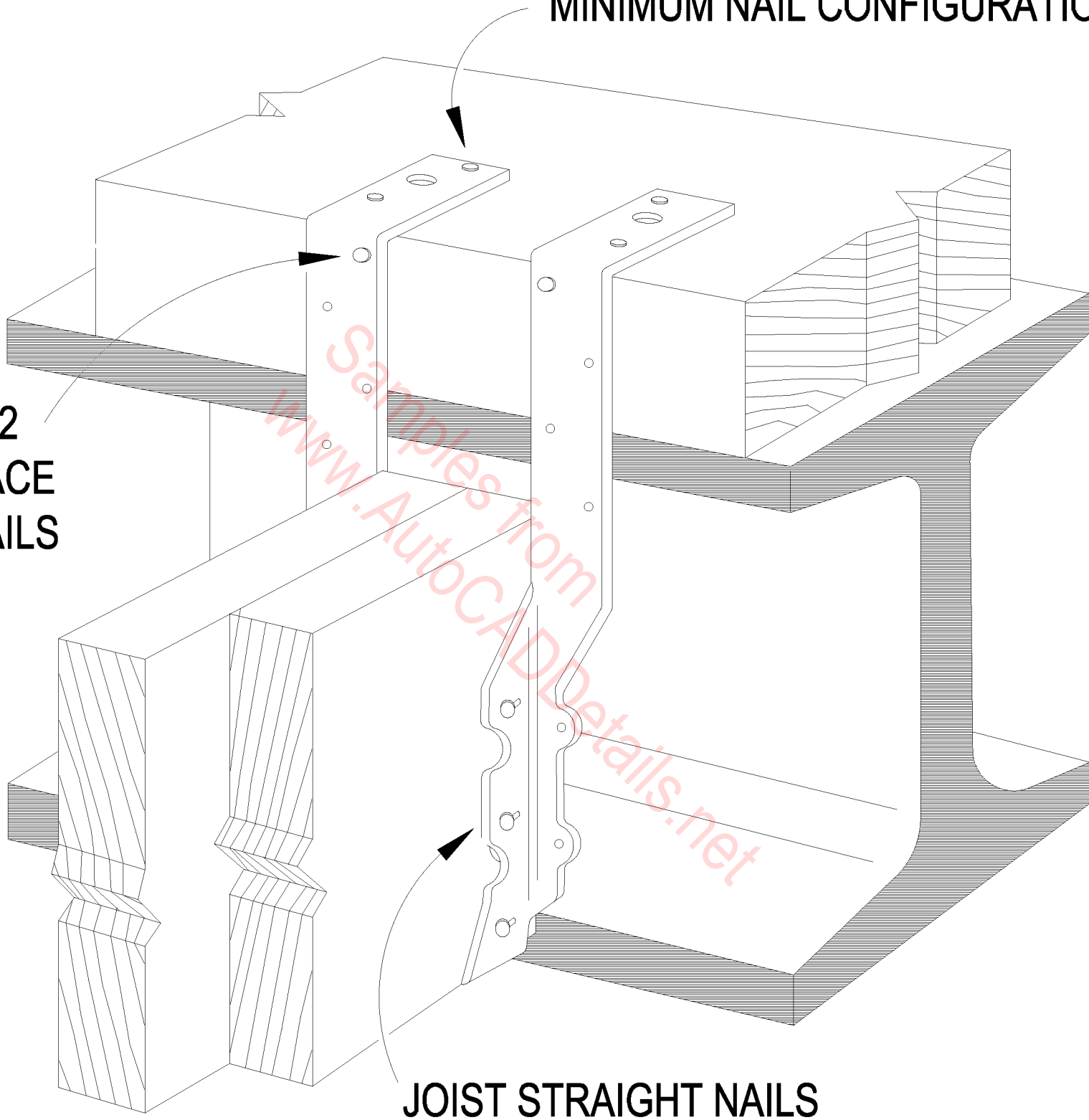

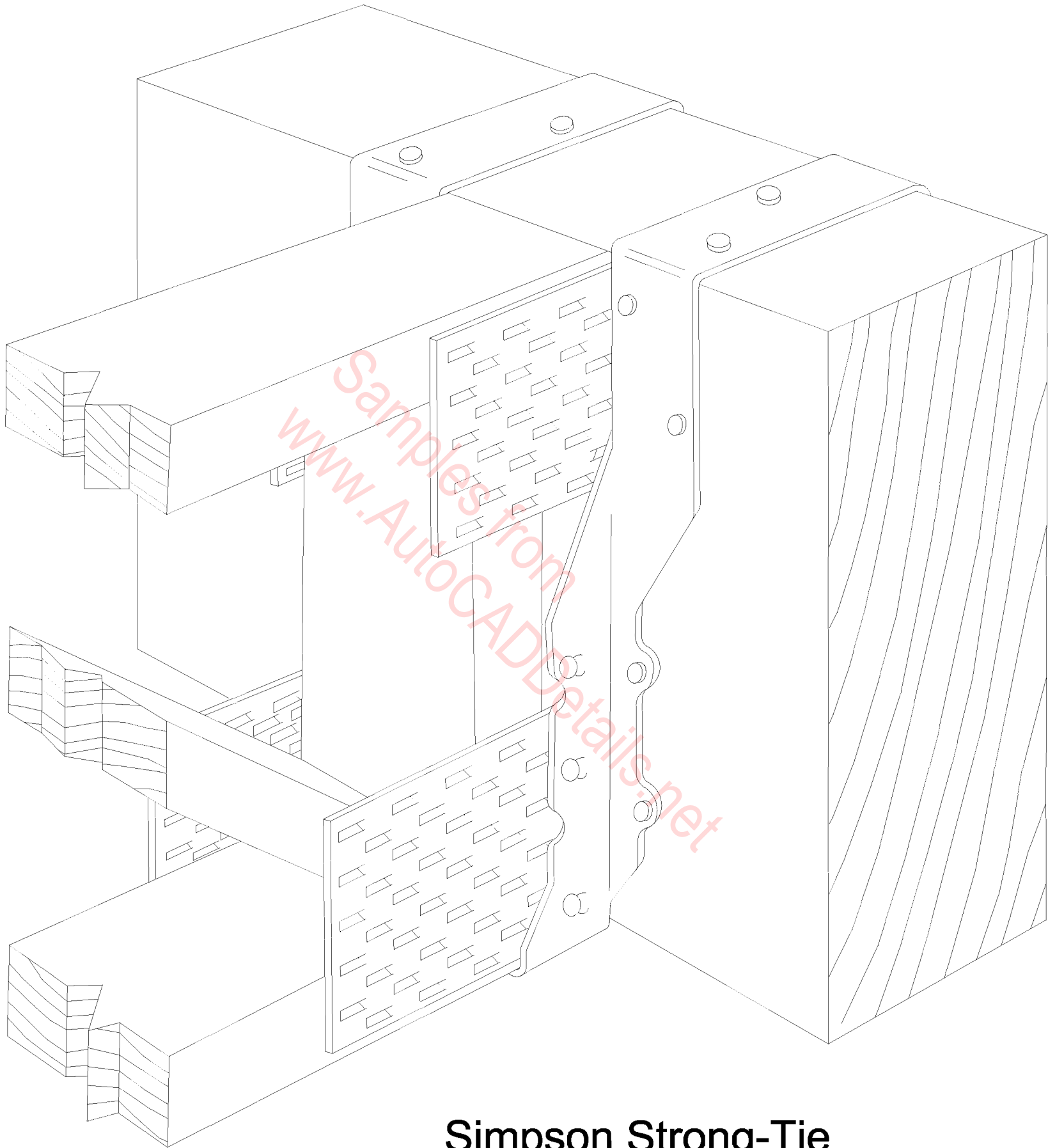

**Simpson Strong-Tie  
THA**

2X6  
MINIMUM

2X8  
MAXIMUM

Samples from  
[www.AutoCADDetails.net](http://www.AutoCADDetails.net)

Simpson Strong-Tie  
THG2AR

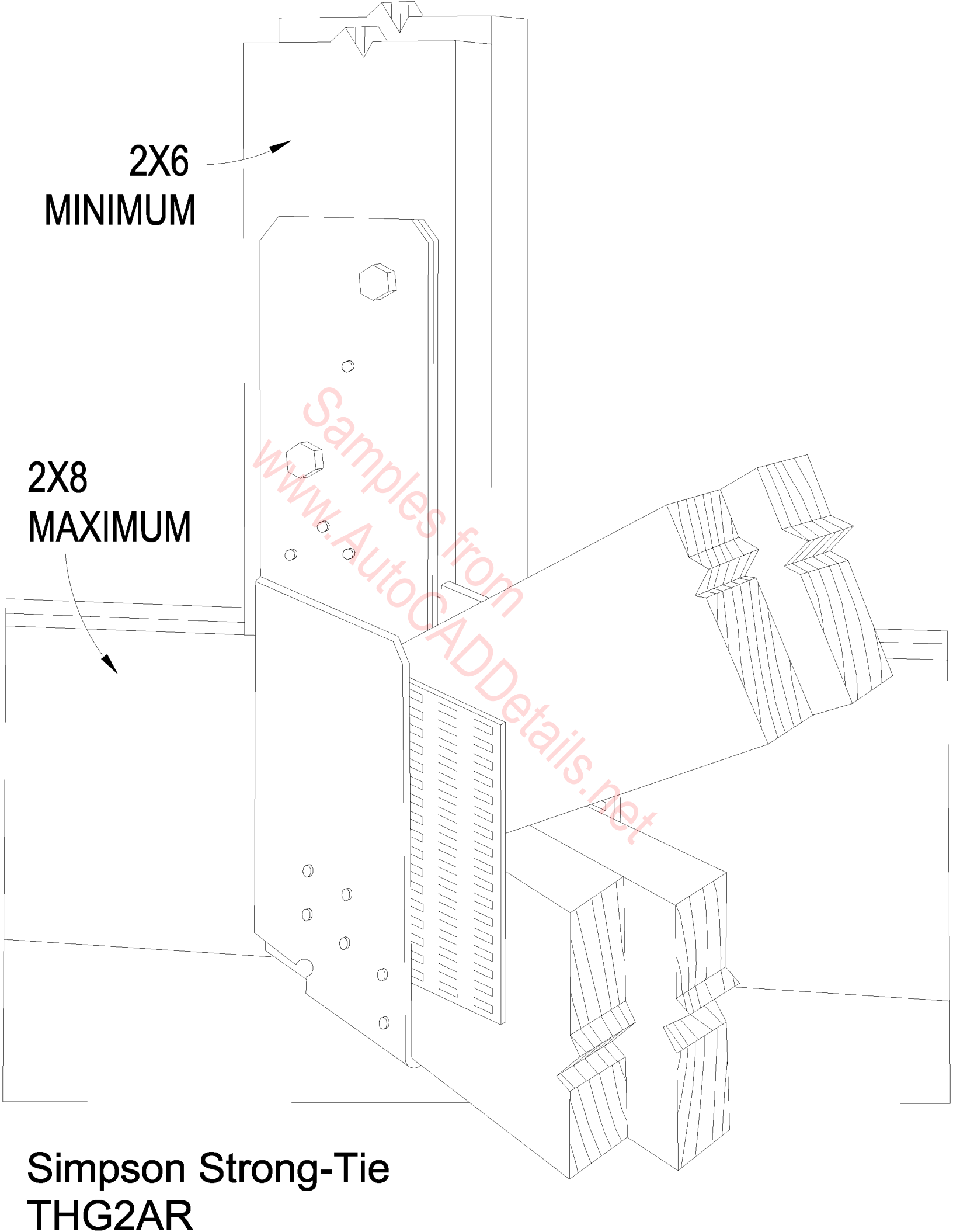

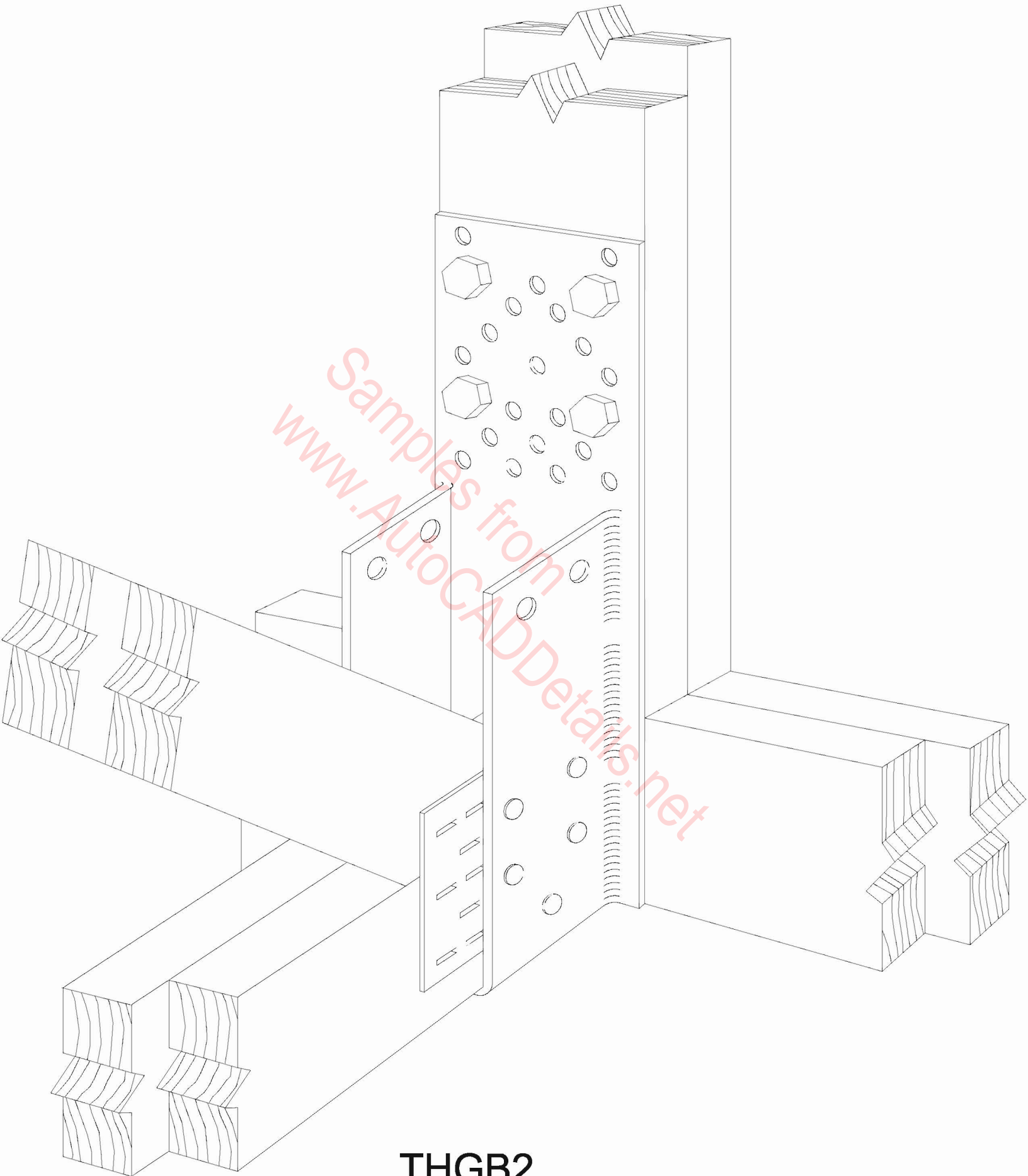

**THGB2**



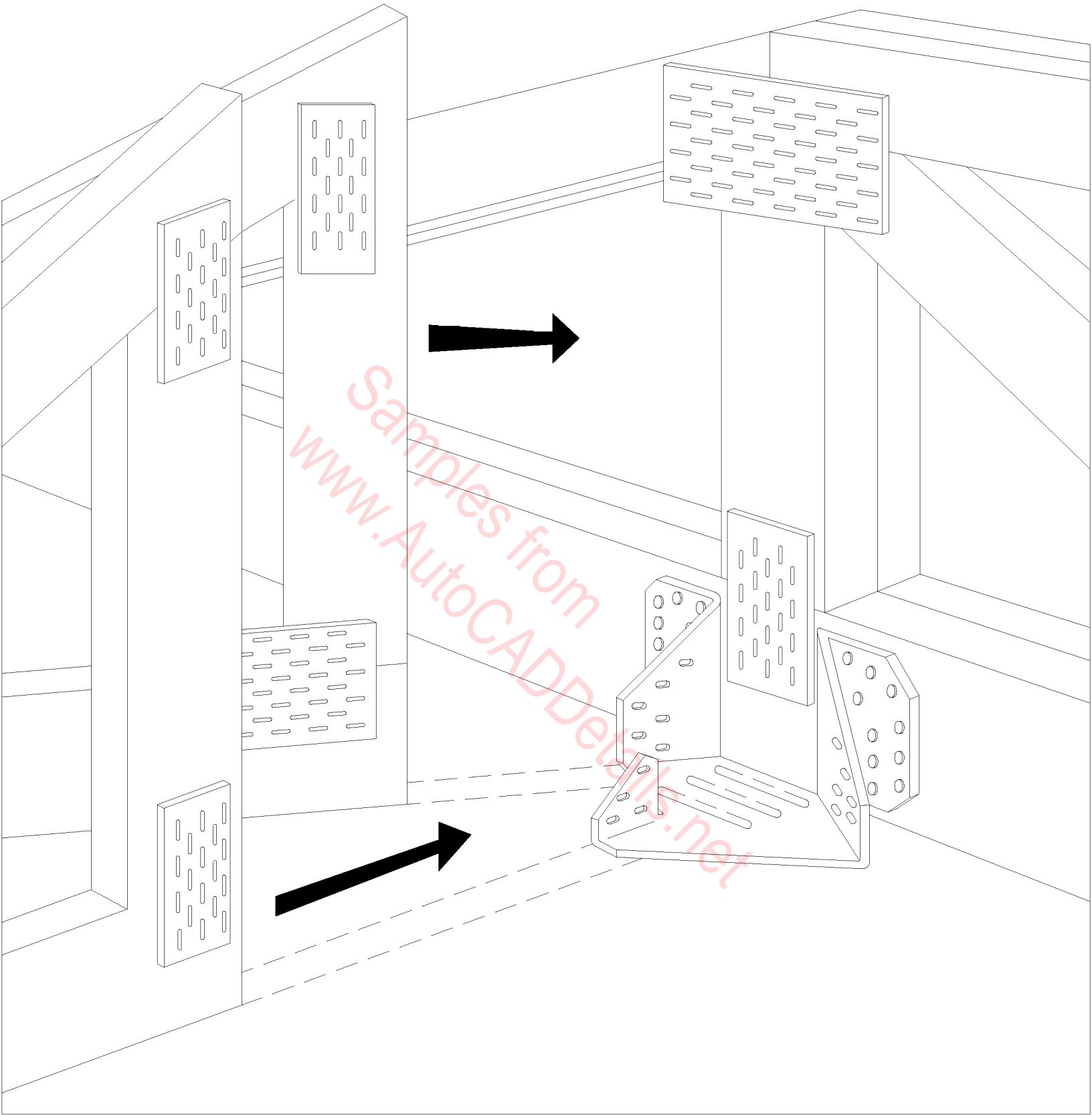

**Simpson Strong-Tie  
THJA26**

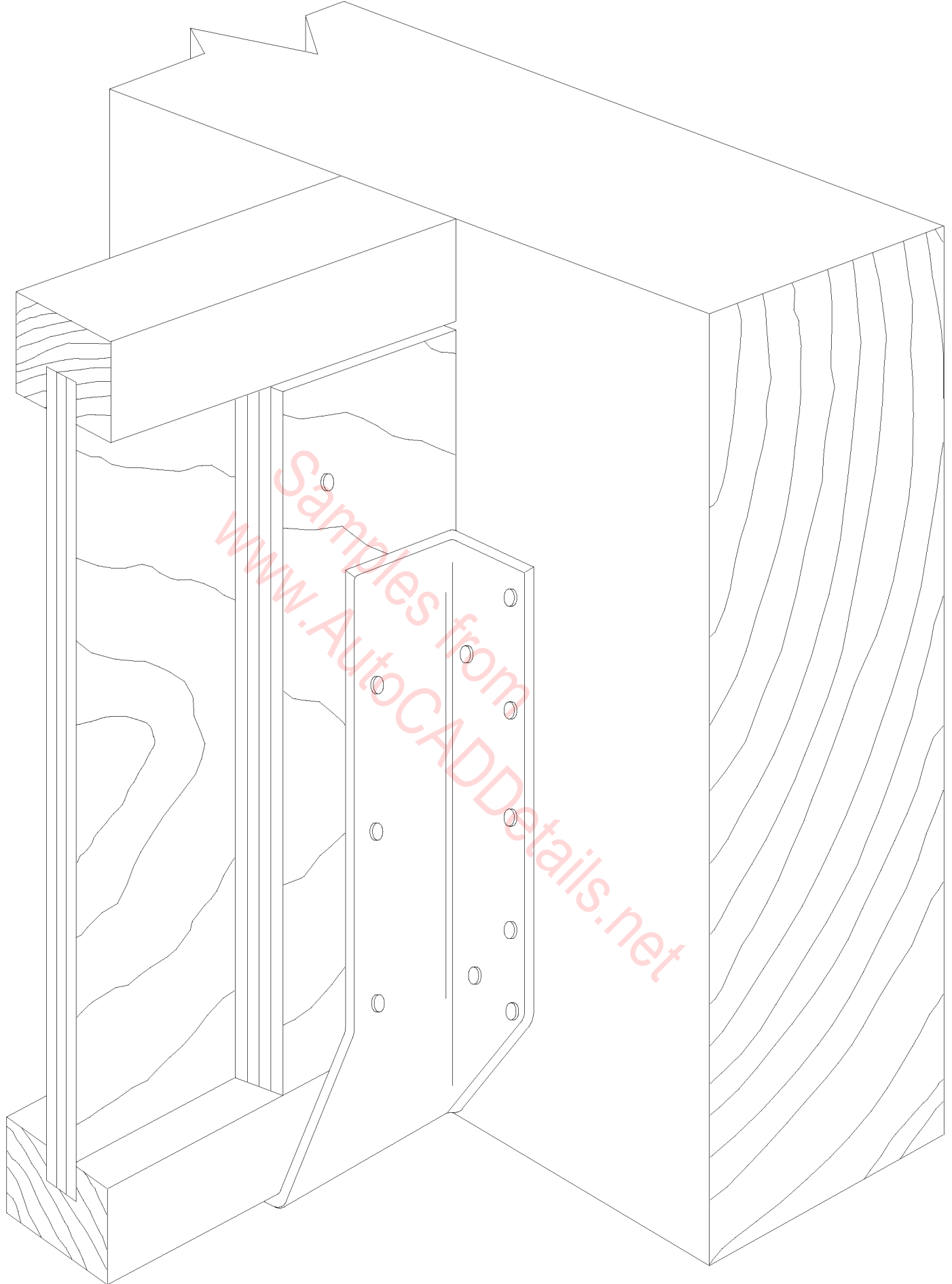

**Simpson Strong-Tie  
U (Wood Web Installation)**

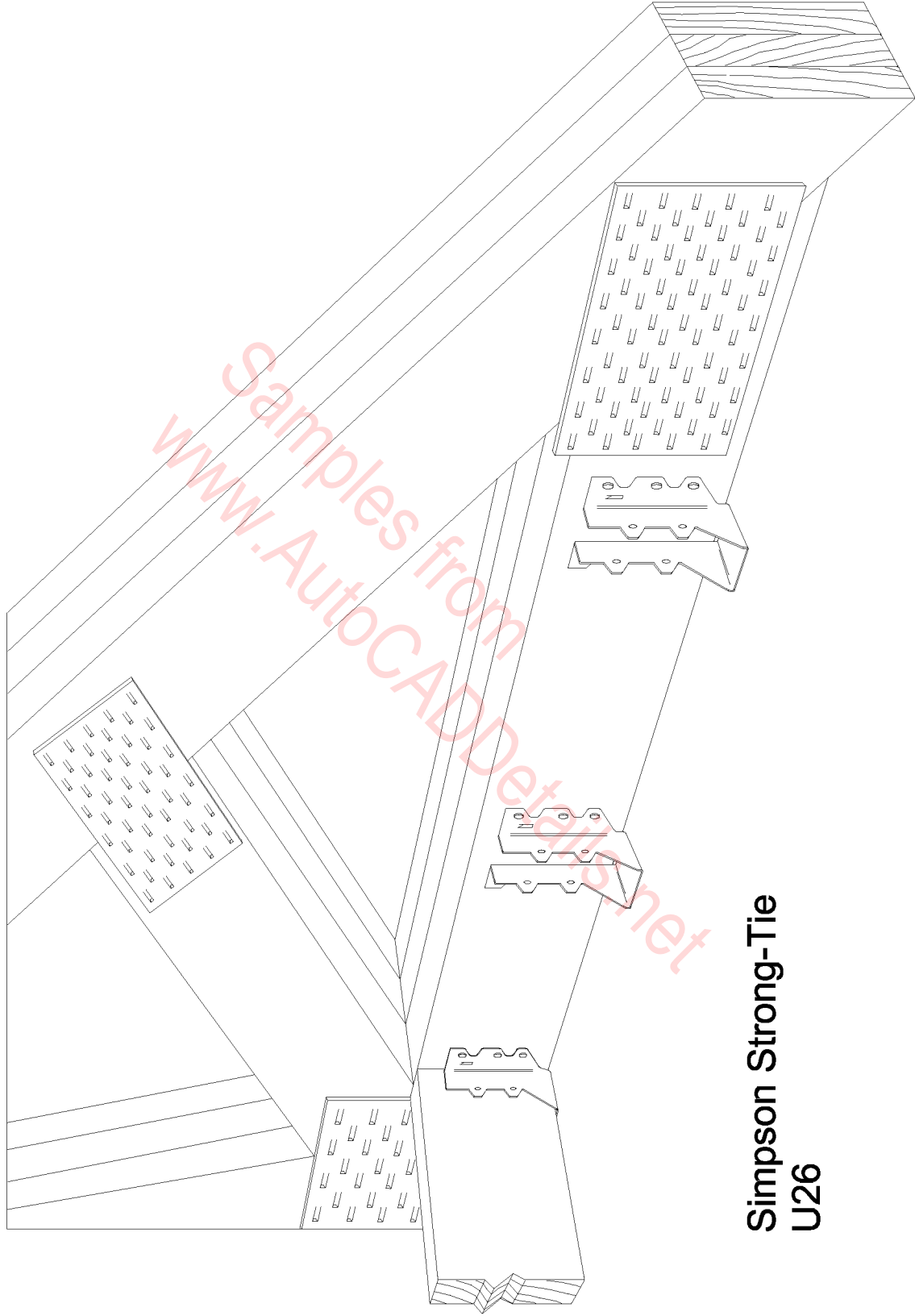

**Simpson Strong-Tie  
U26**

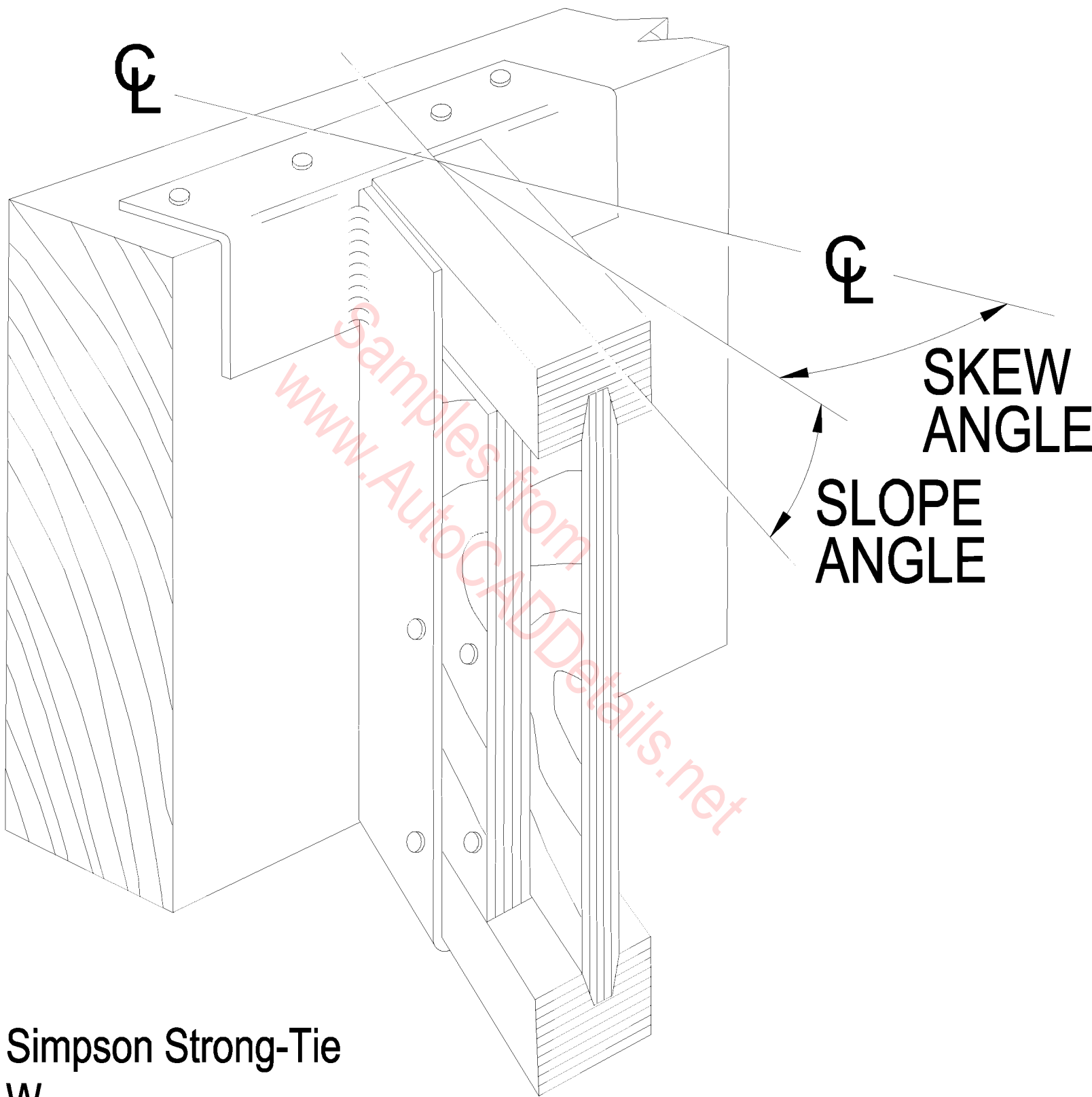

**Simpson Strong-Tie**  
**W**

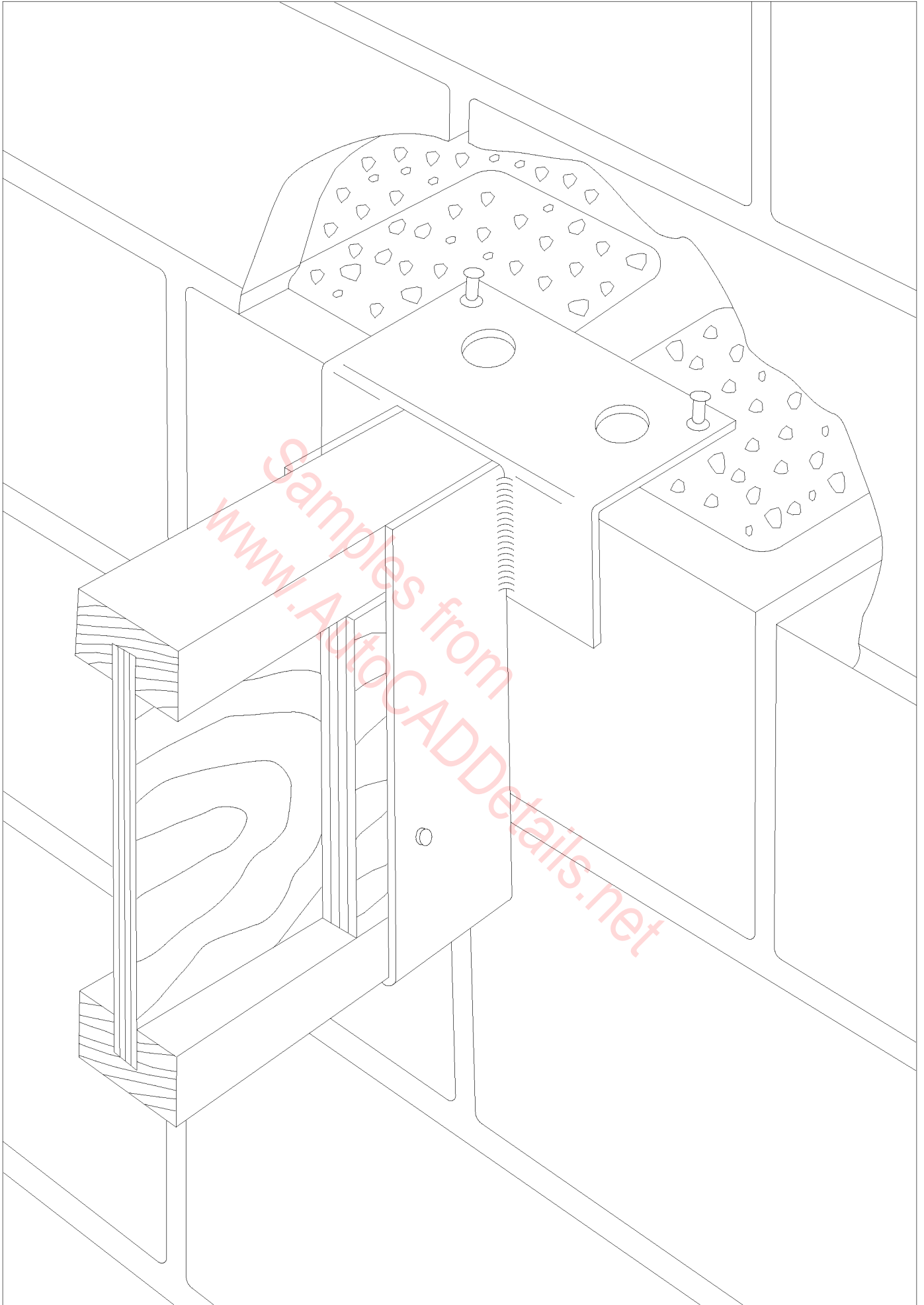

Simpson Strong-Tie  
WM

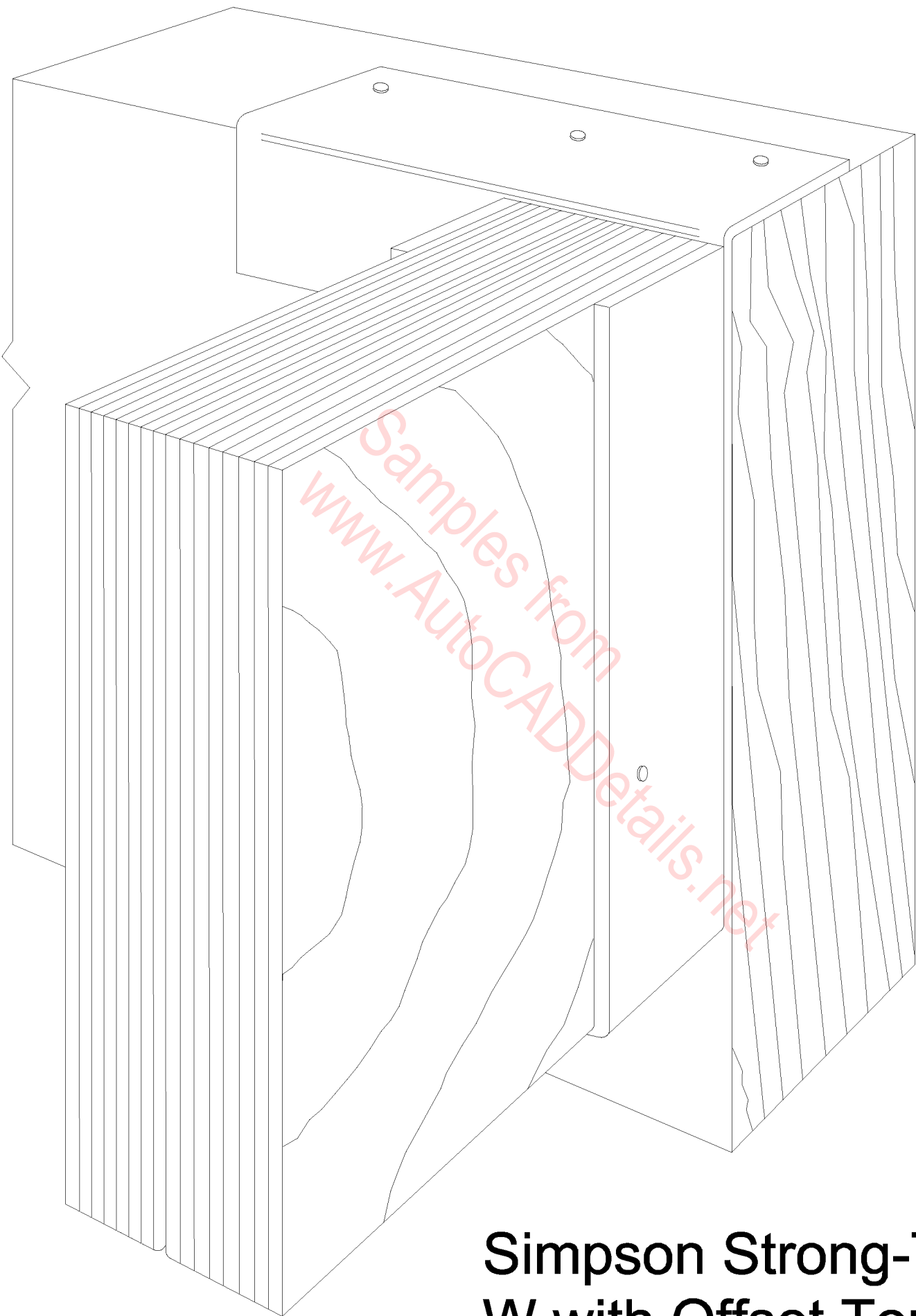

**Simpson Strong-Tie  
W with Offset Top Flange**

SPECIFY LOW SIDE, HIGH SIDE, OR  
CENTER FLUSH (LOW SIDE SHOWN)

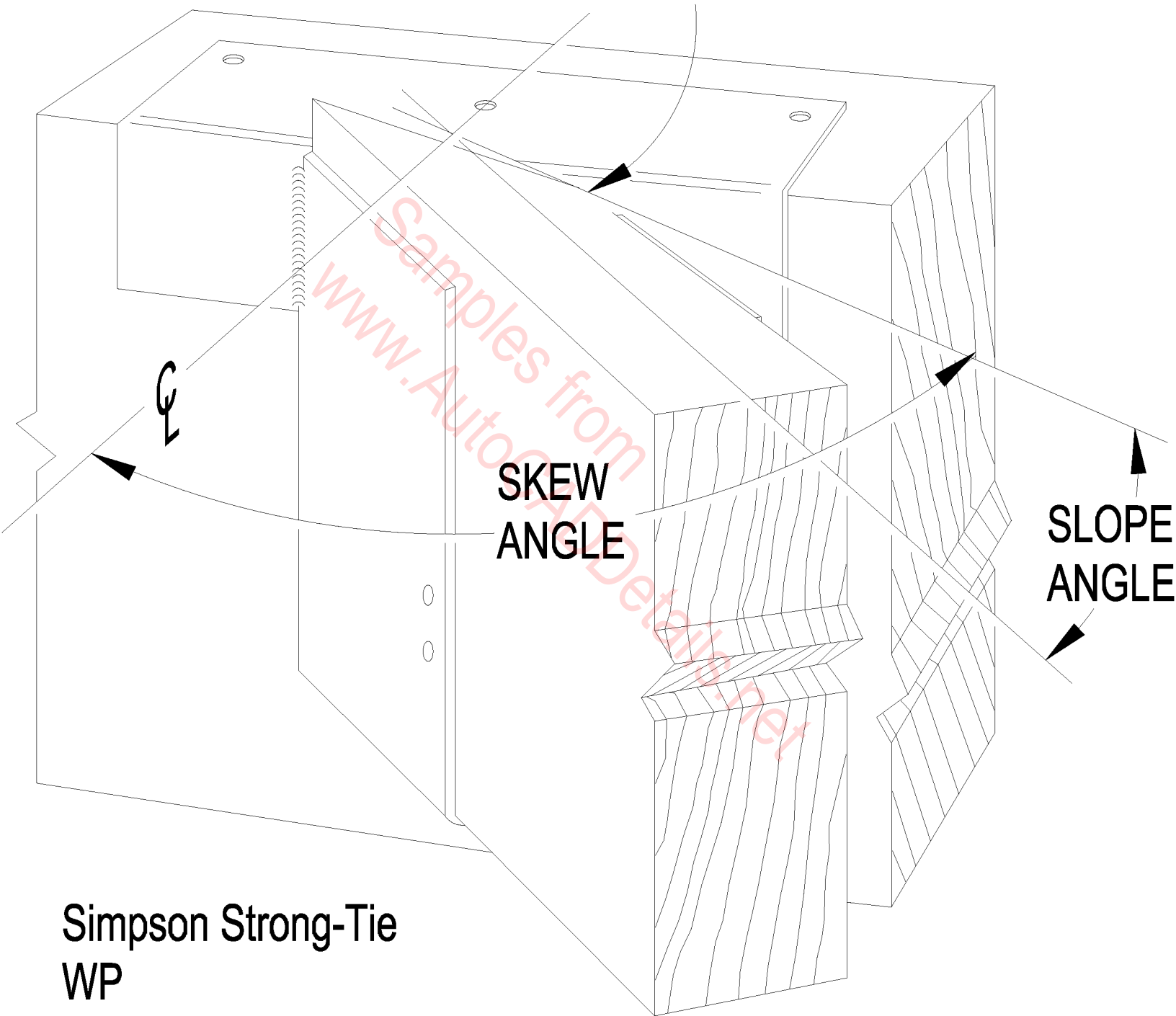

Simpson Strong-Tie  
WP  
Type A Hanger

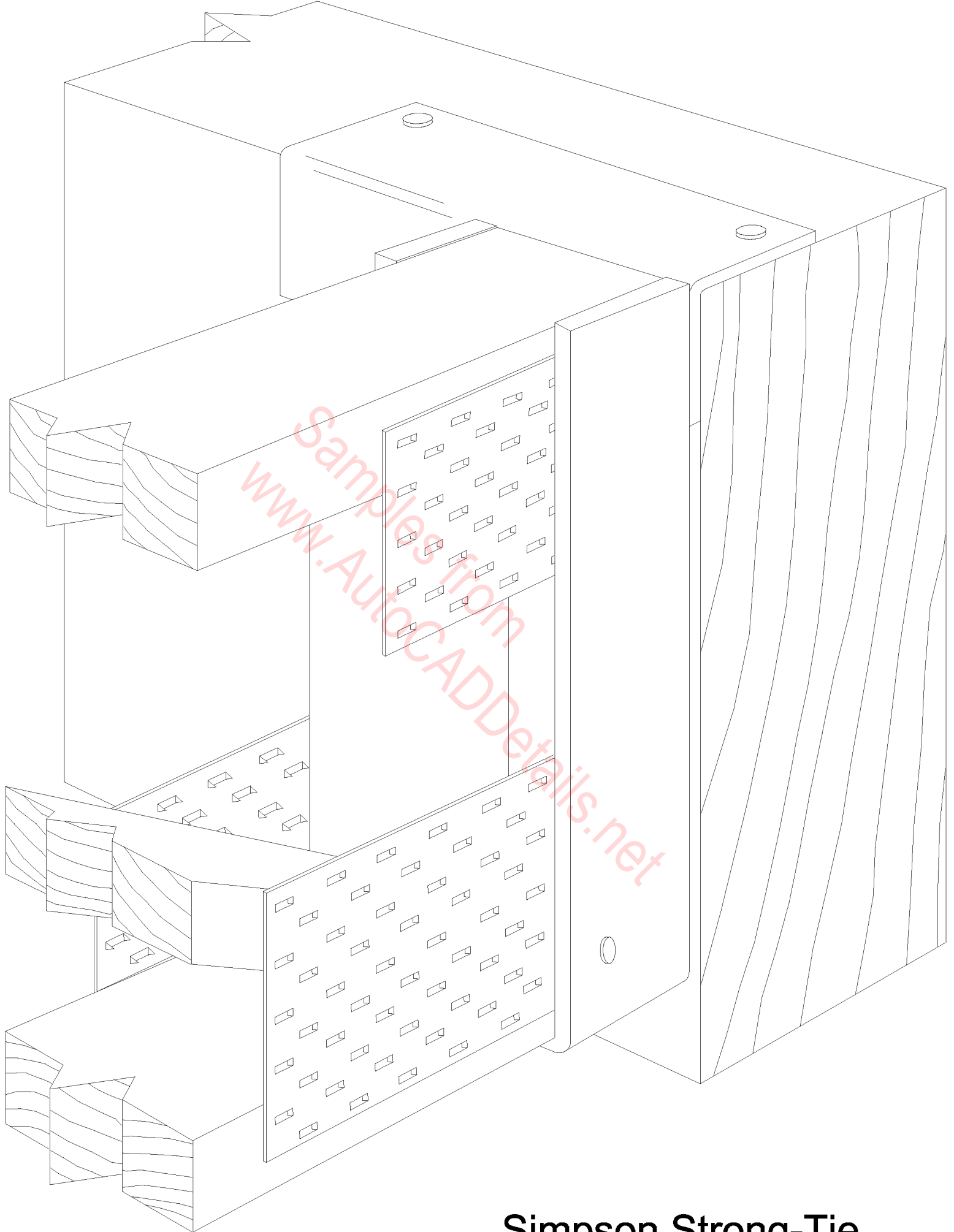

**Simpson Strong-Tie  
WPT**



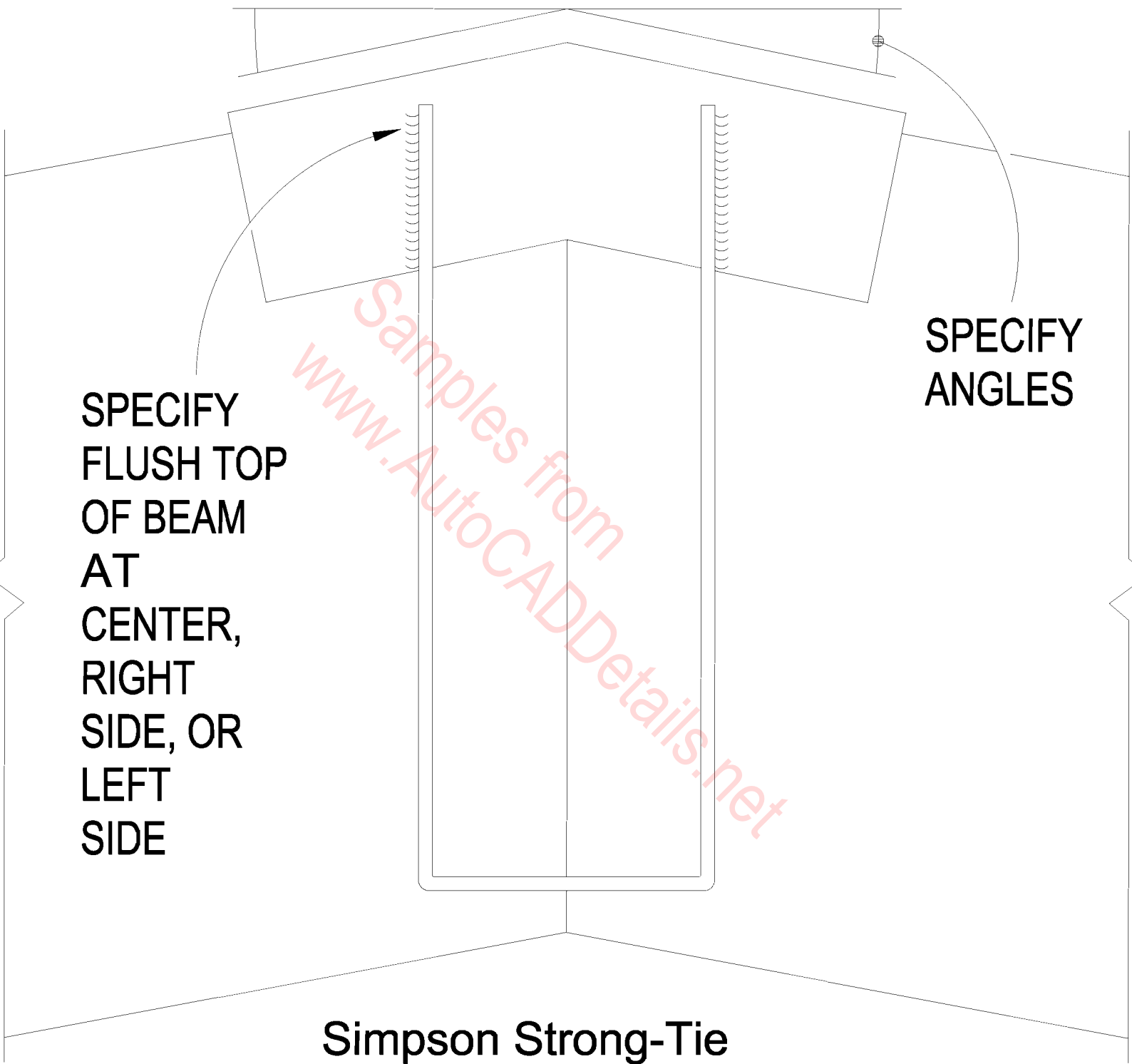

SPECIFY  
FLUSH TOP  
OF BEAM  
AT  
CENTER,  
RIGHT  
SIDE, OR  
LEFT  
SIDE

SPECIFY  
ANGLES

Simpson Strong-Tie  
W

**SPECIFY  
ANGLE**

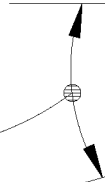

**SPECIFY  
LOW SIDE,  
HIGH SIDE,  
OR CENTER  
FLUSH WITH  
HEADER.  
(LOW SIDE  
FLUSH  
SHOWN)**

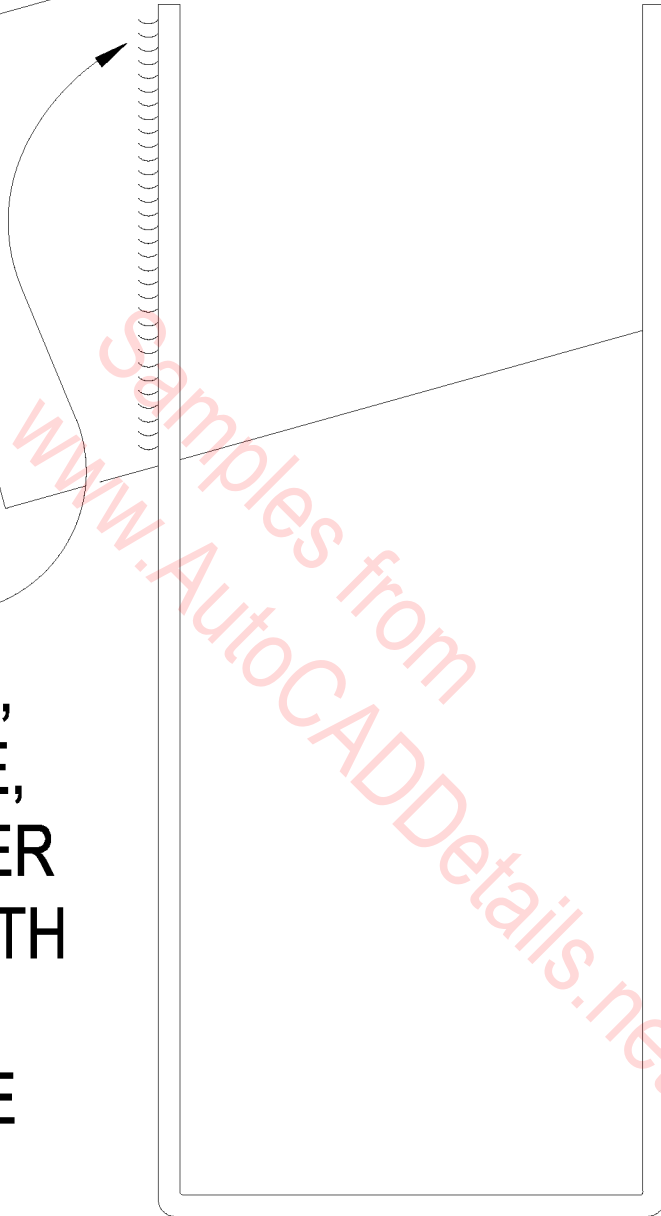

**Simpson Strong-Tie  
W**

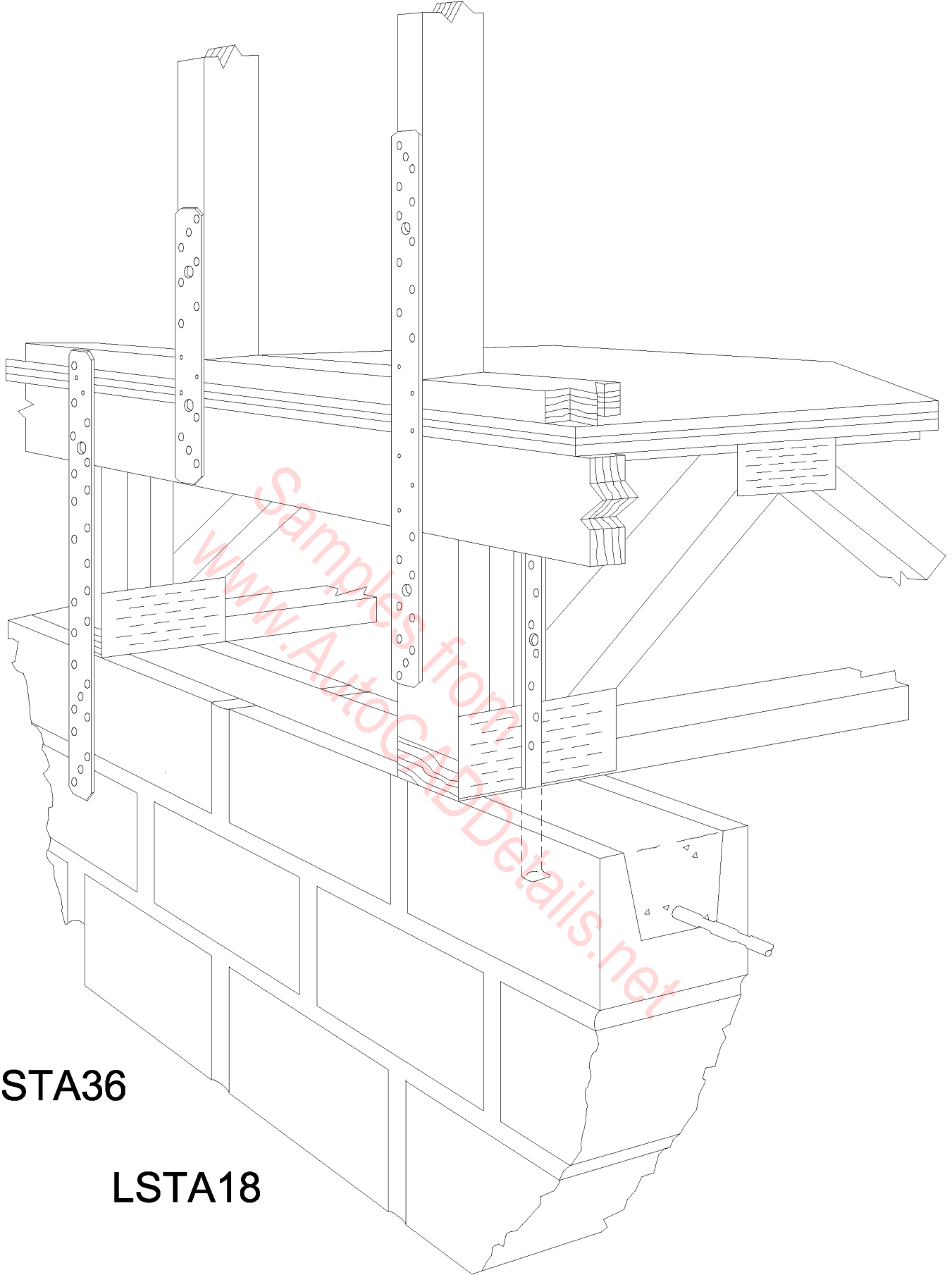

**LSTA36**

**LSTA18**

**LSTA36**

**META20**

**Simpson Strong-Tie  
Floor-to-Floor Connections**

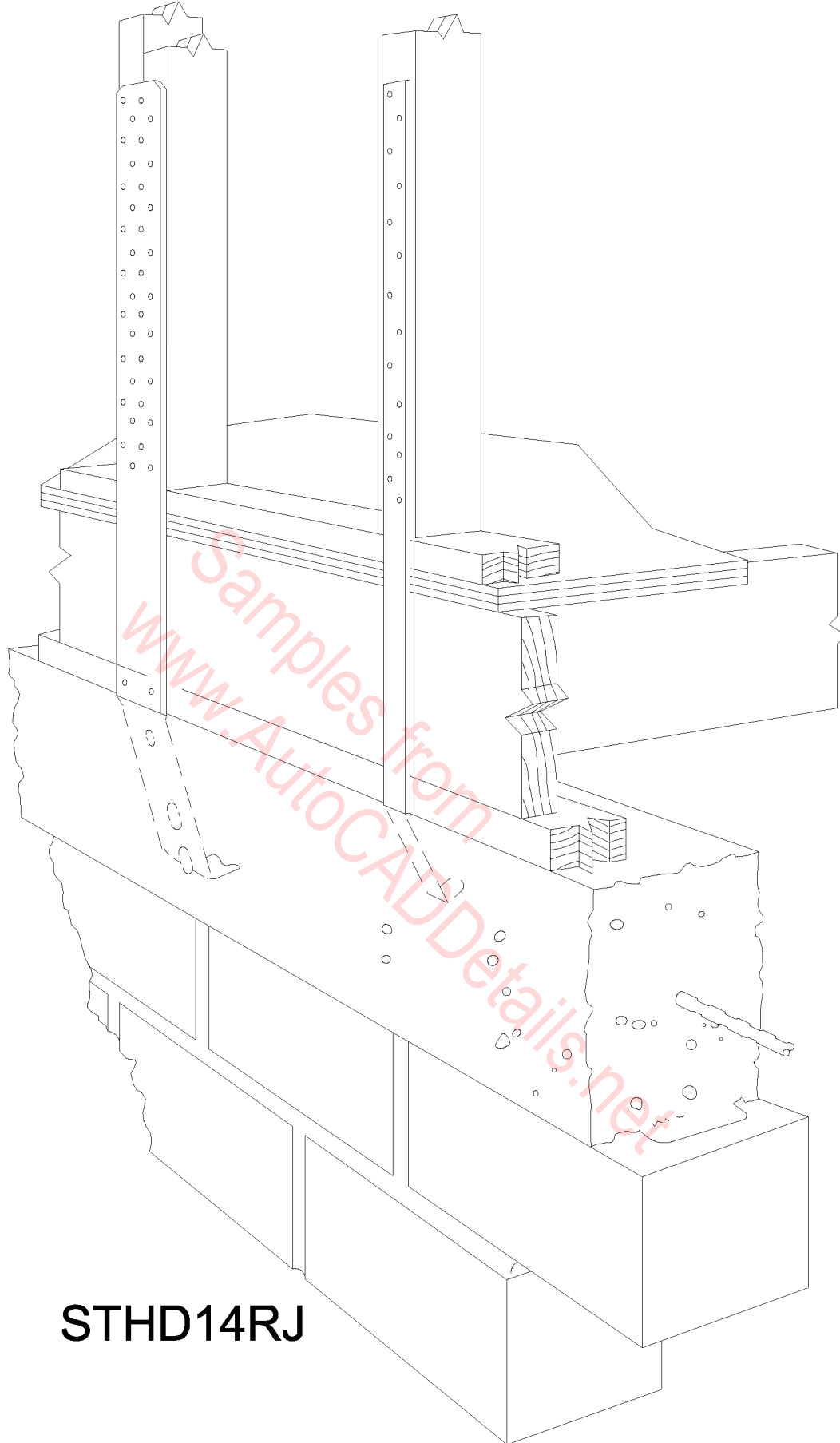

**STHD14RJ**

**HETA40**

**Simpson Strong-Tie  
Floor-to-Floor Connections**

MTS12

LFTA

CS16

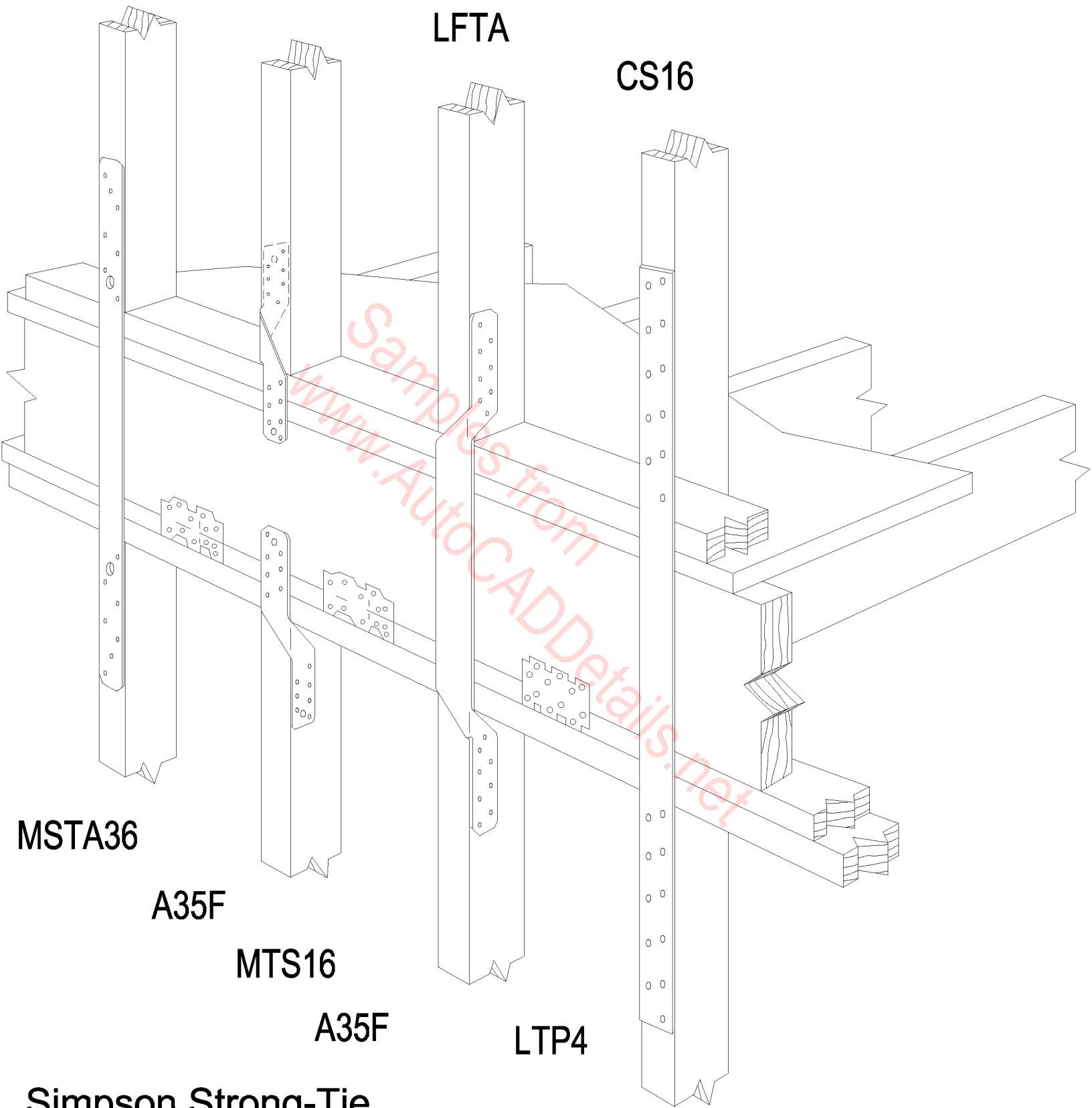

MSTA36

A35F

MTS16

A35F

LTP4

Simpson Strong-Tie  
Floor-to-Floor Connections

MTS16

LSTA18

HD2A

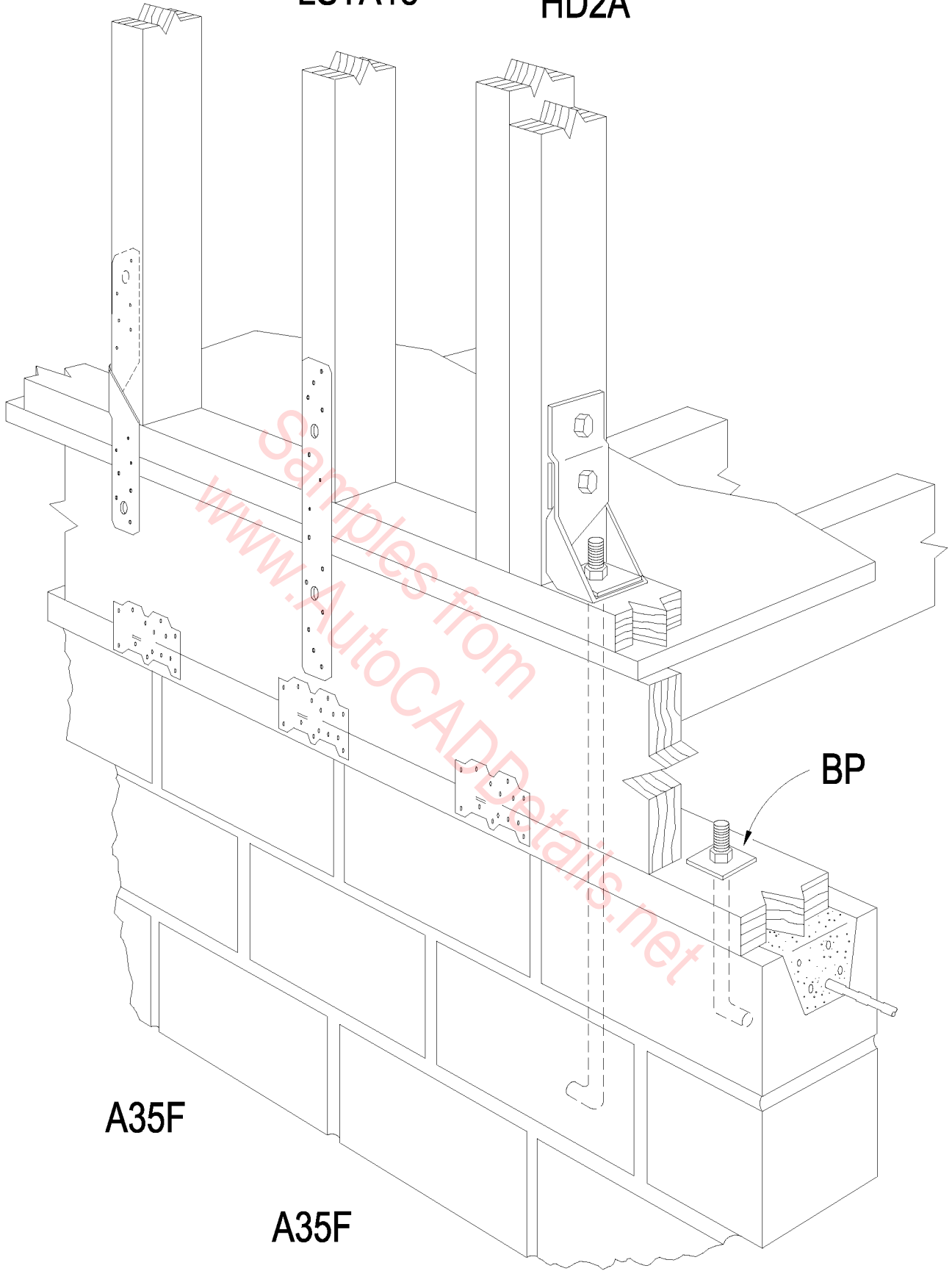

A35F

A35F

A35F

BP

**Simpson Strong-Tie  
Floor-to-Floor Connections**

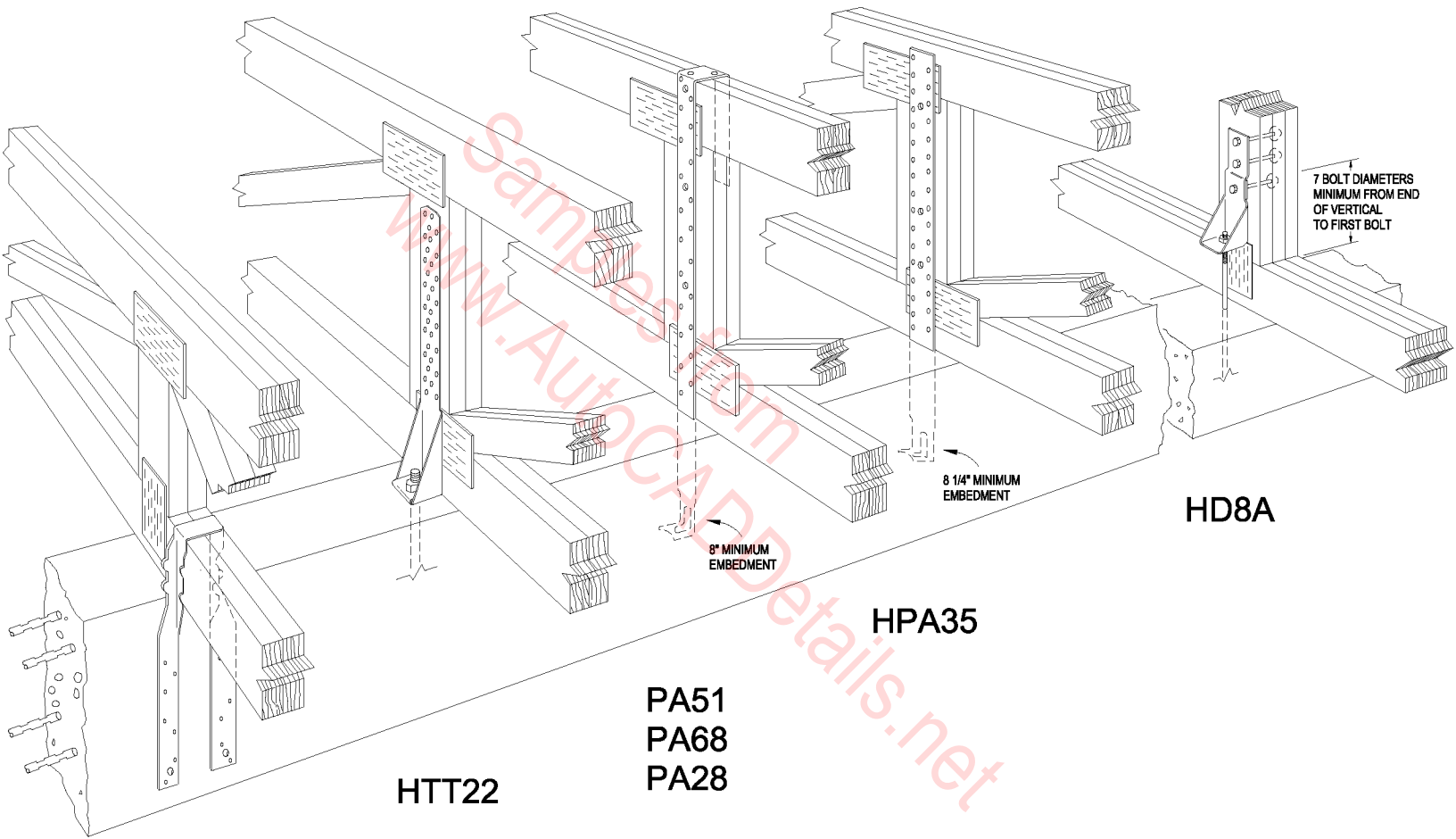

**Simpson Strong-Tie  
Girder/Truss to Concrete**

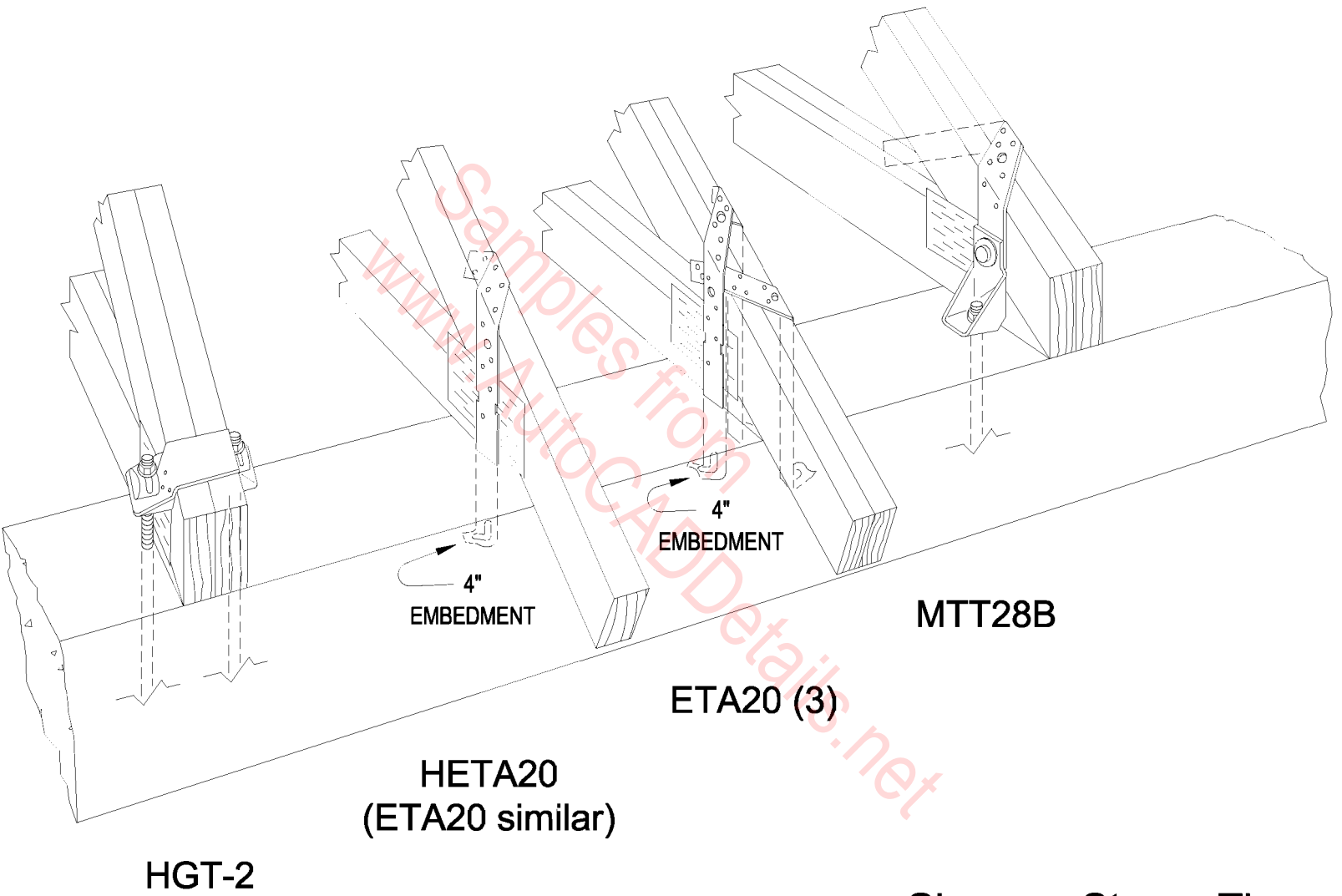

Simpson Strong-Tie  
Girder/Truss to Concrete



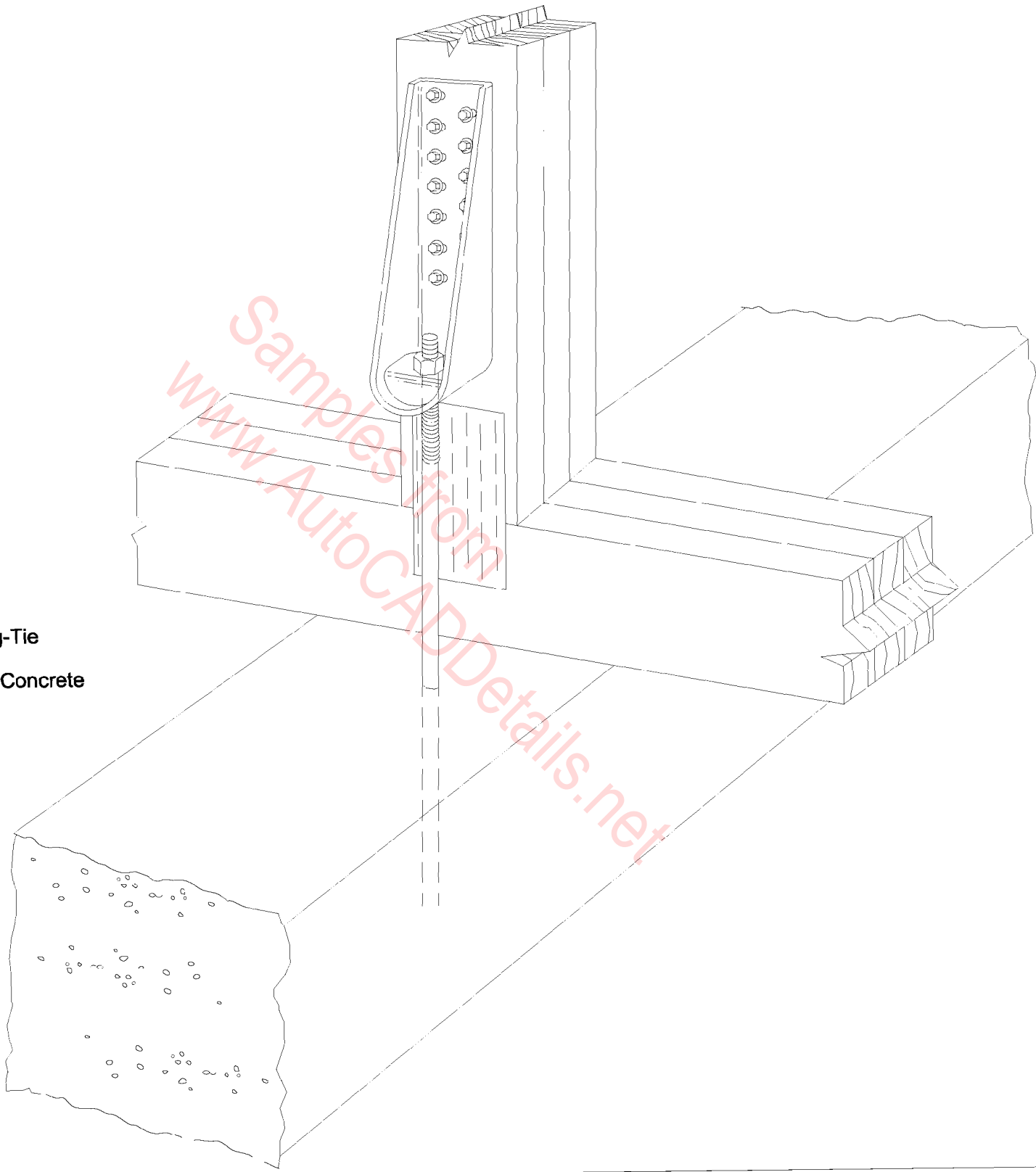

Simpson Strong-Tie  
PHD5  
Girder/Truss to Concrete

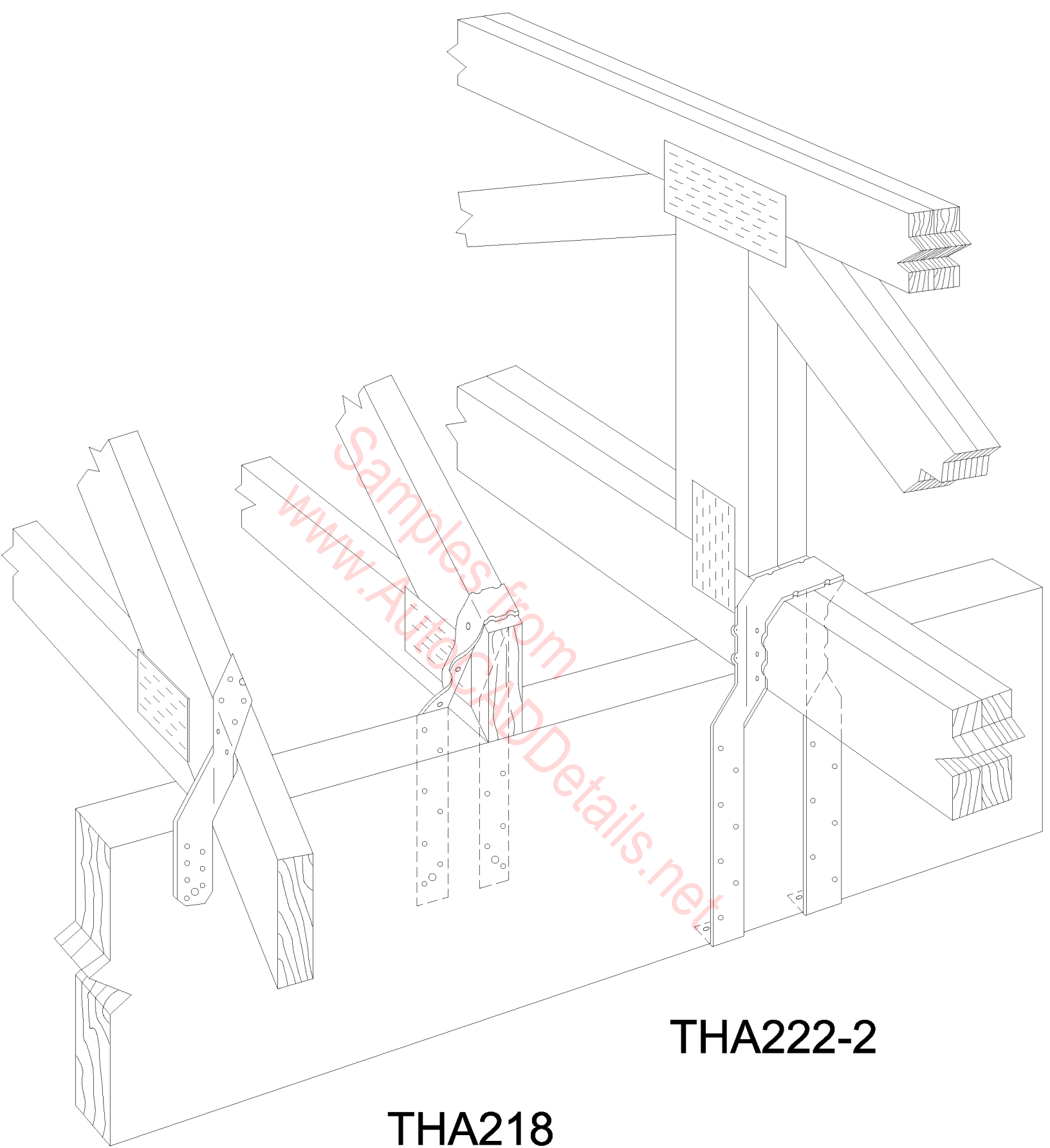

**MTS12**

**THA218**

**THA222-2**

**Simpson Strong-Tie  
Girder/Truss to Top Plates  
and Wood Headers**

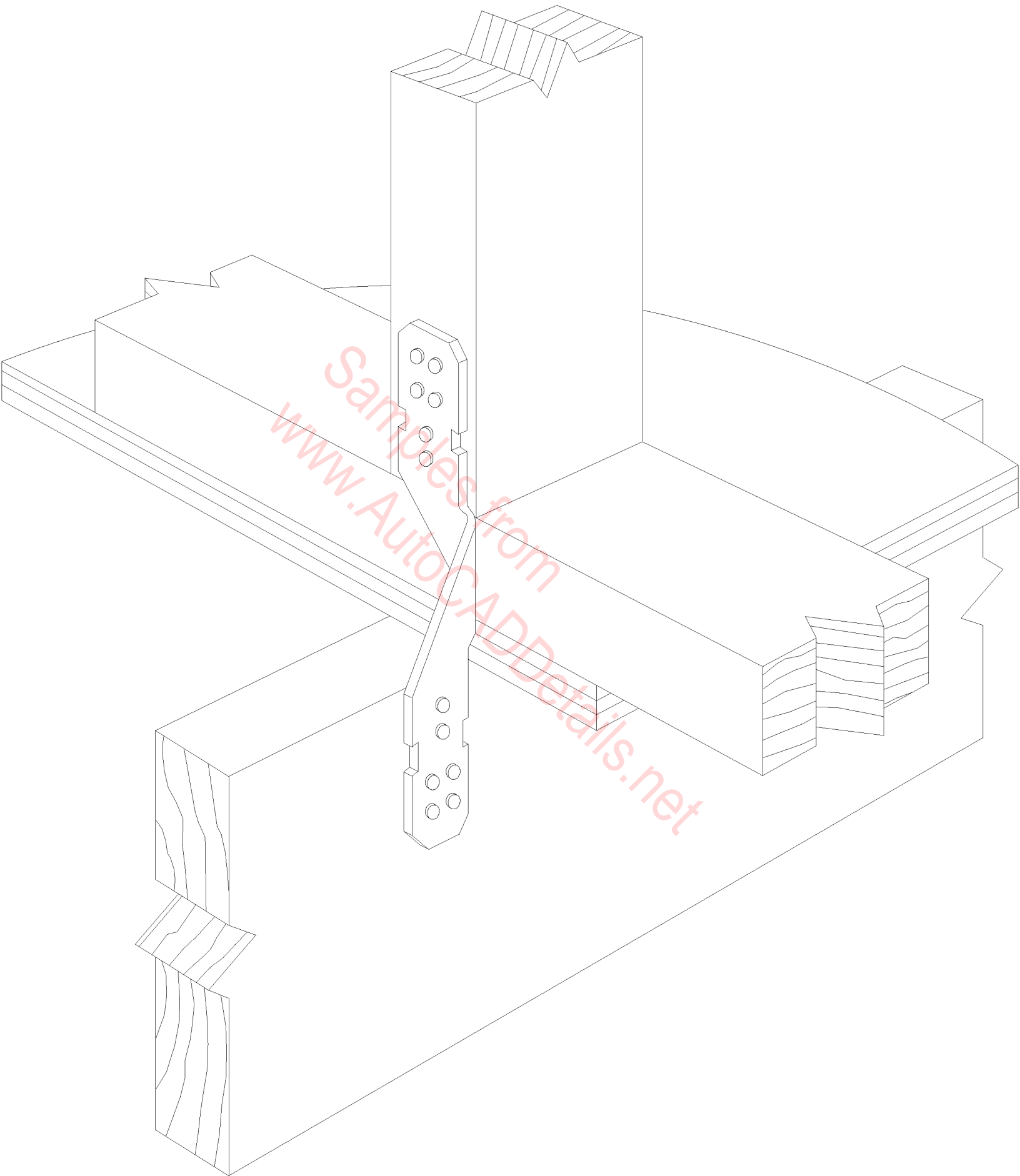

**MTS16**

**PA51**

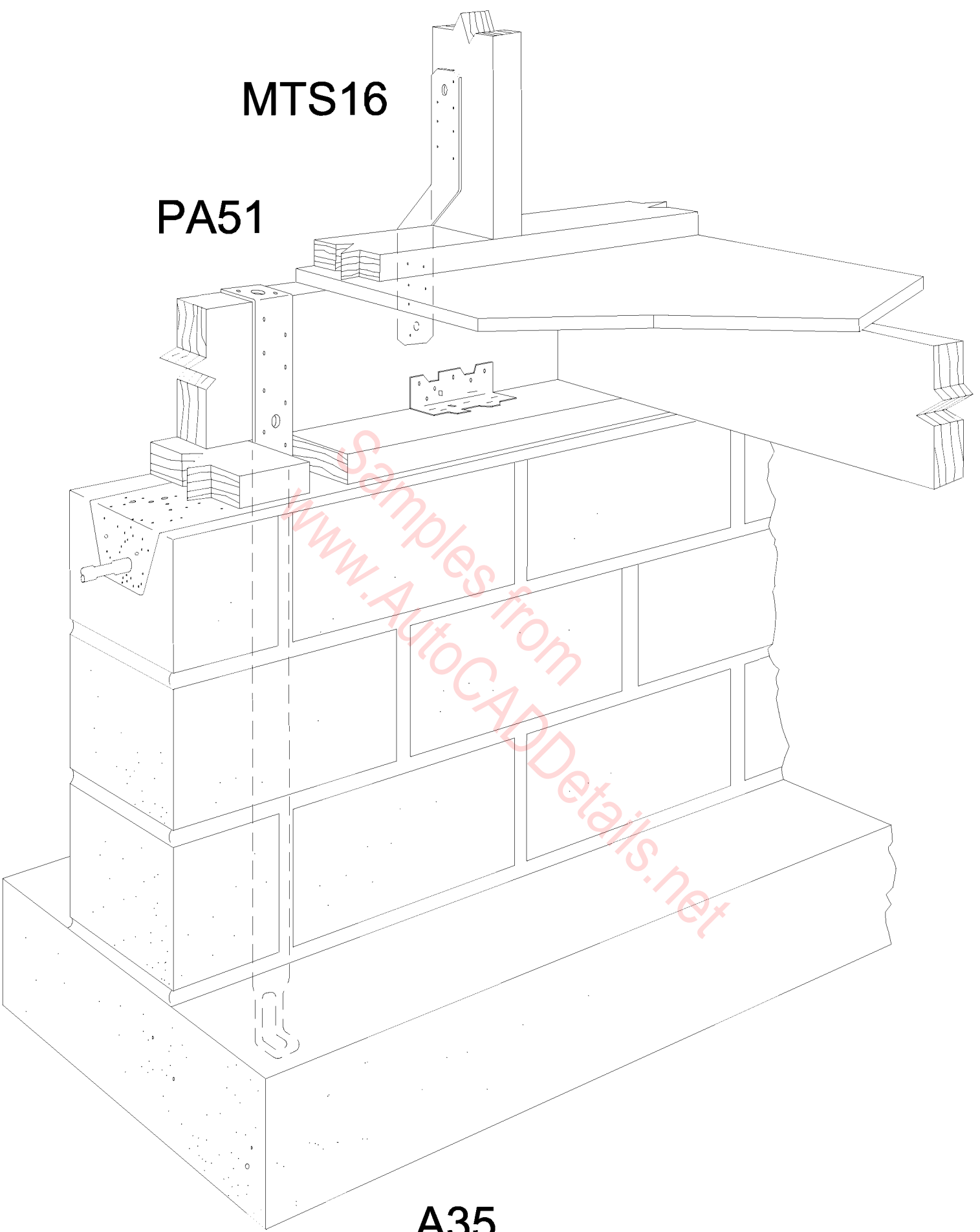

**A35**

**Simpson Strong-Tie  
Lateral Load Connections**

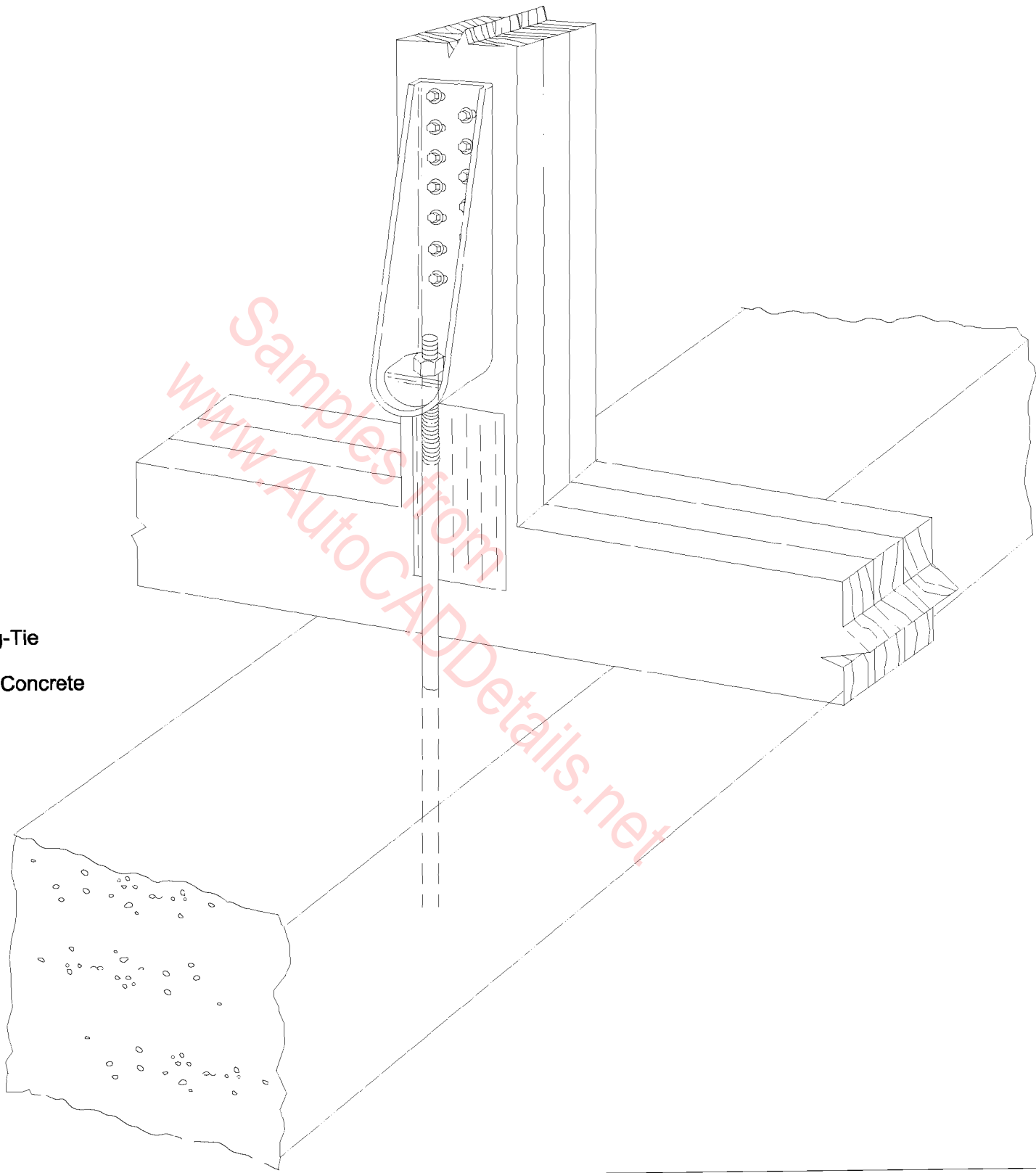

Simpson Strong-Tie  
PHD5  
Girder/Truss to Concrete

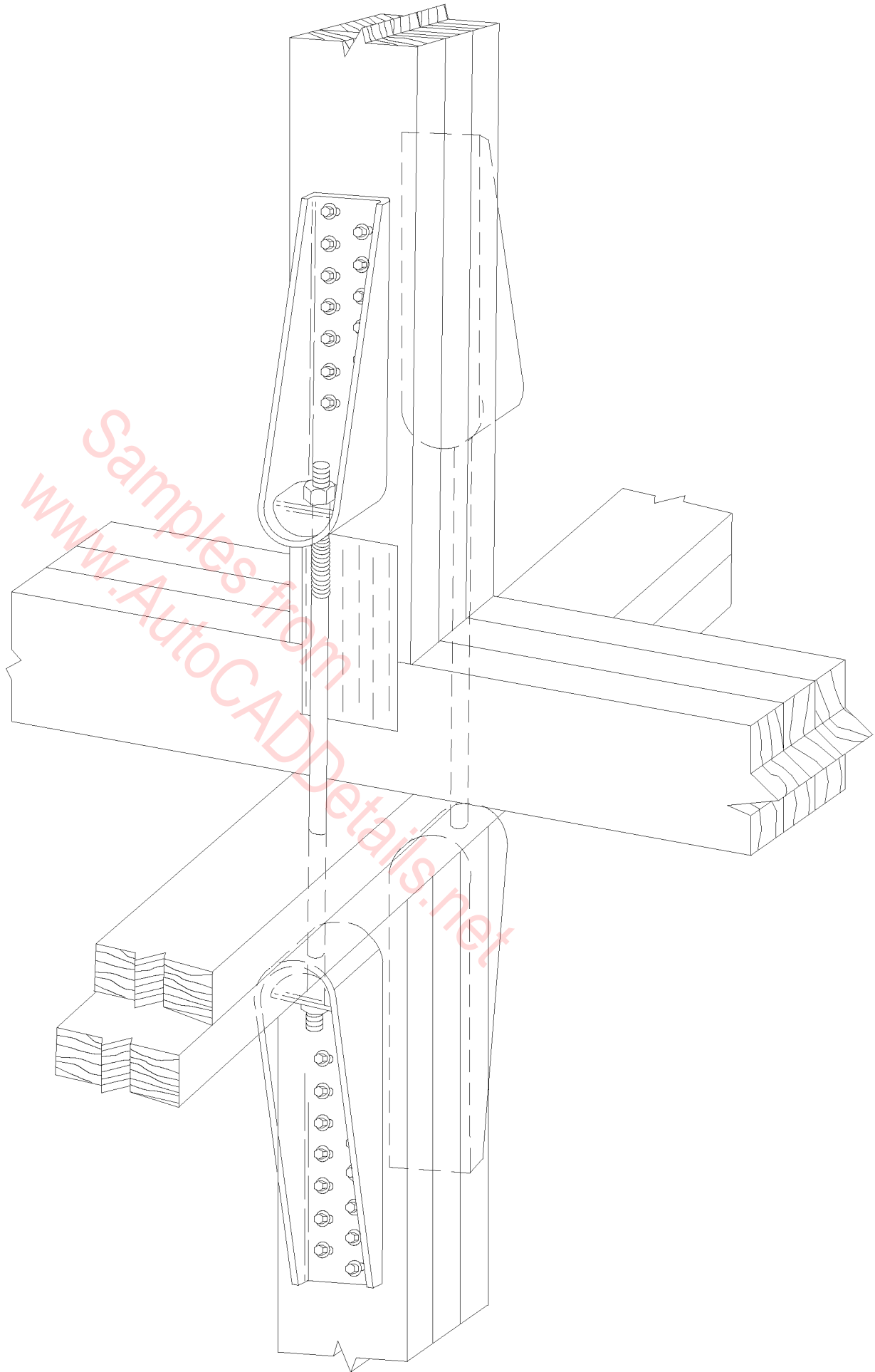

Simpson Strong-Tie  
PHD5  
Girder/Truss to Top Plates  
and Wood Headers

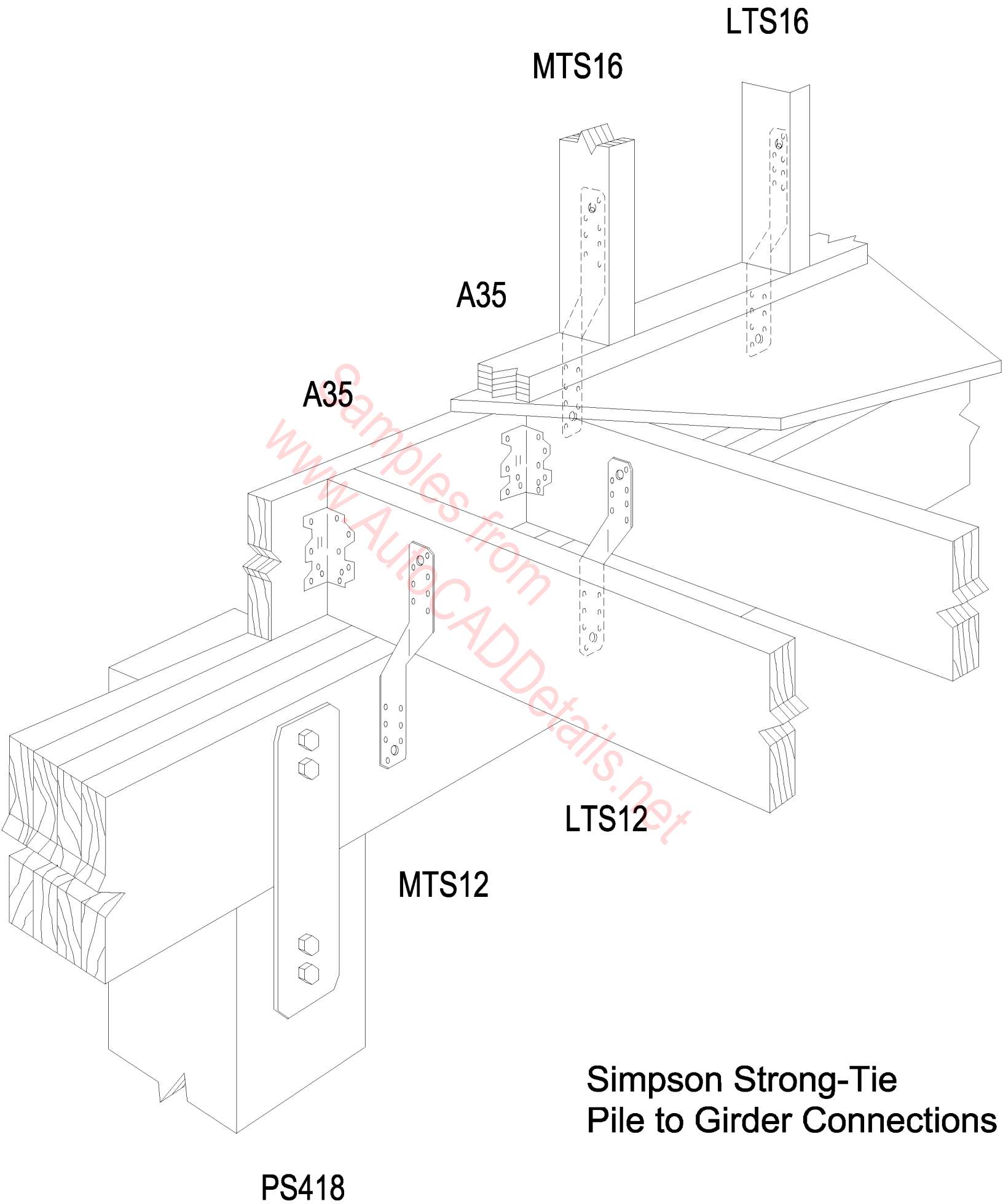

**Simpson Strong-Tie  
Pile to Girder Connections**

LSTA18

CS16

MTS16

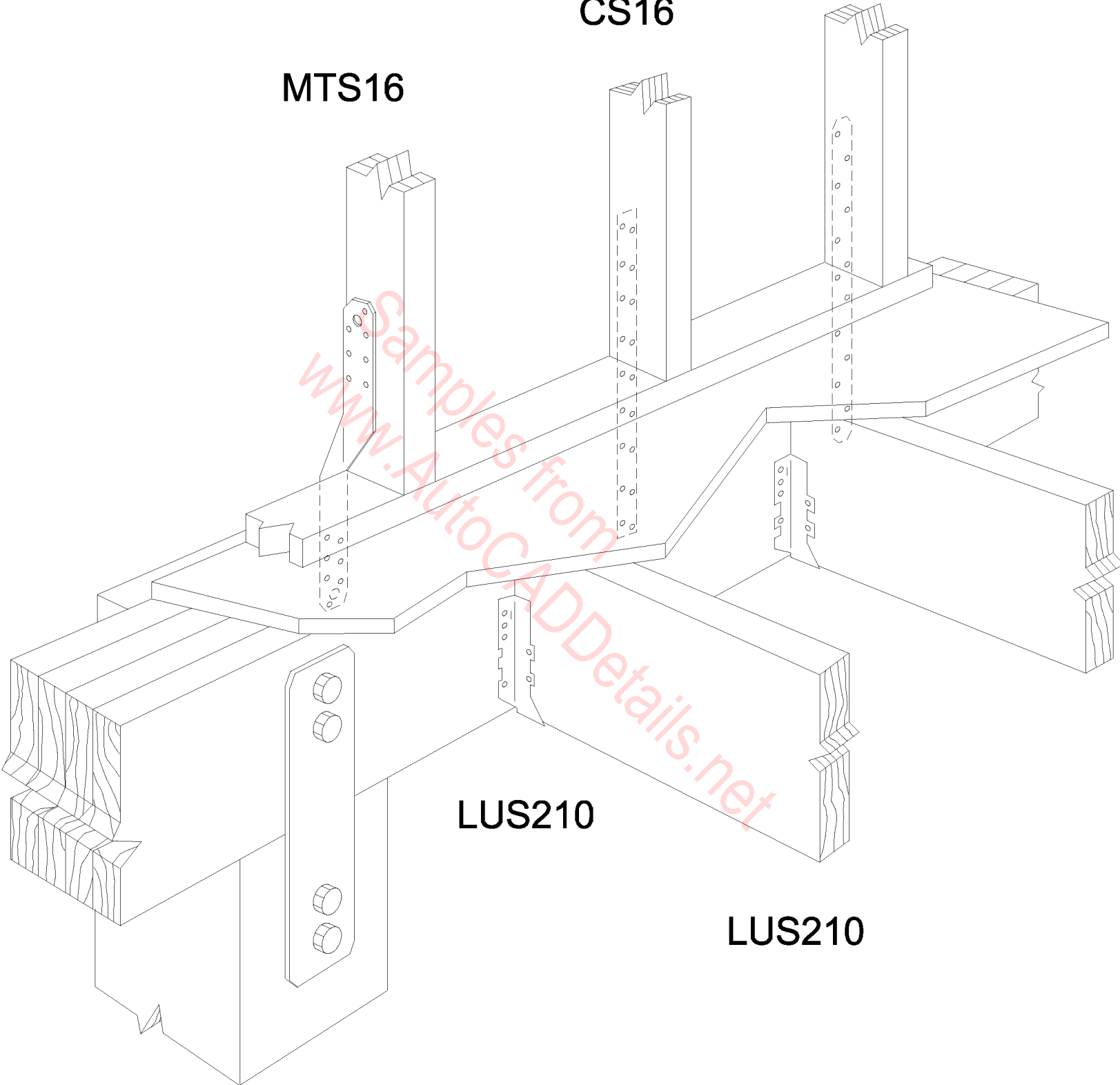

LUS210

LUS210

PS418

**Simpson Strong-Tie  
Pile to Girder Connections**



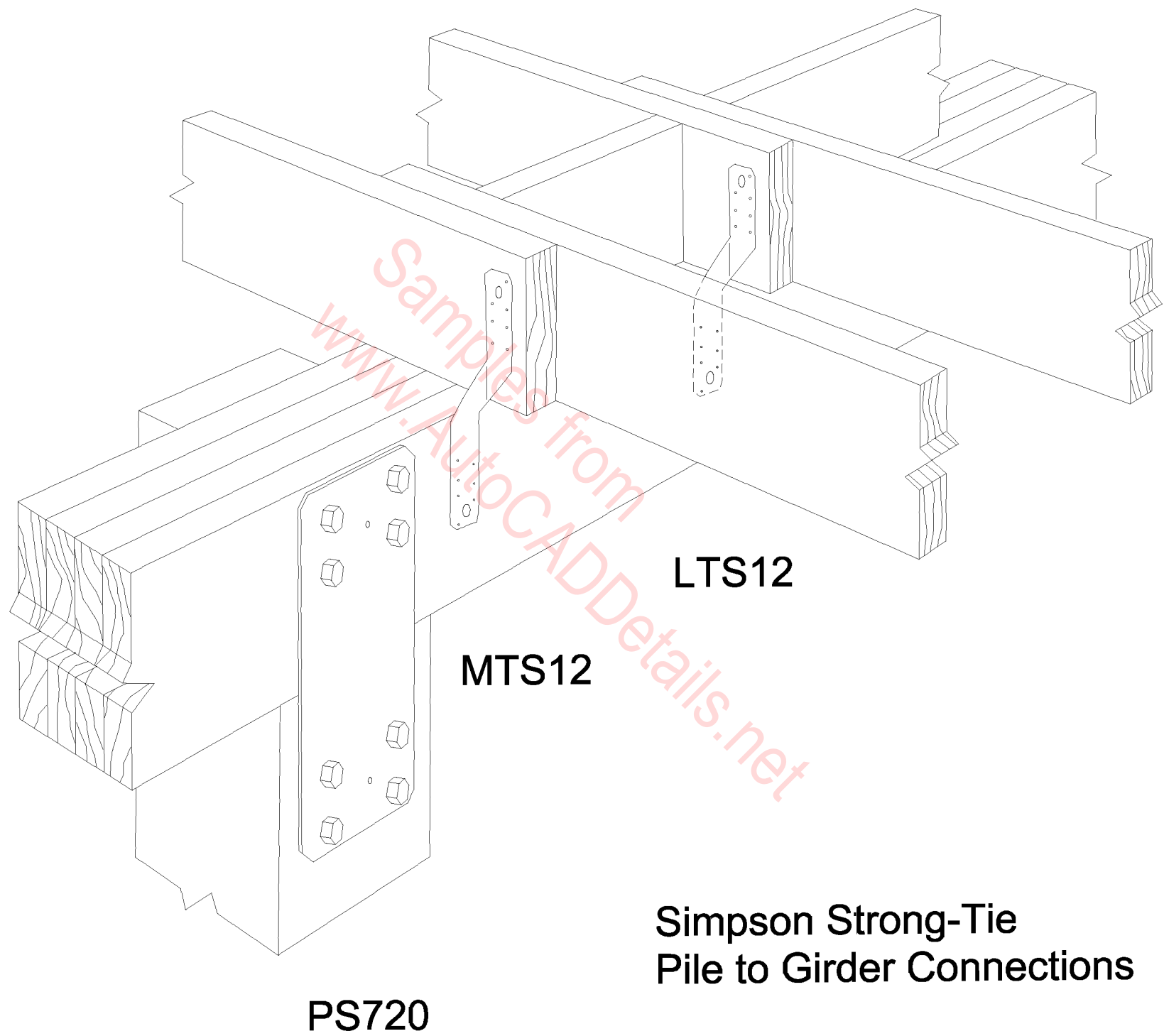

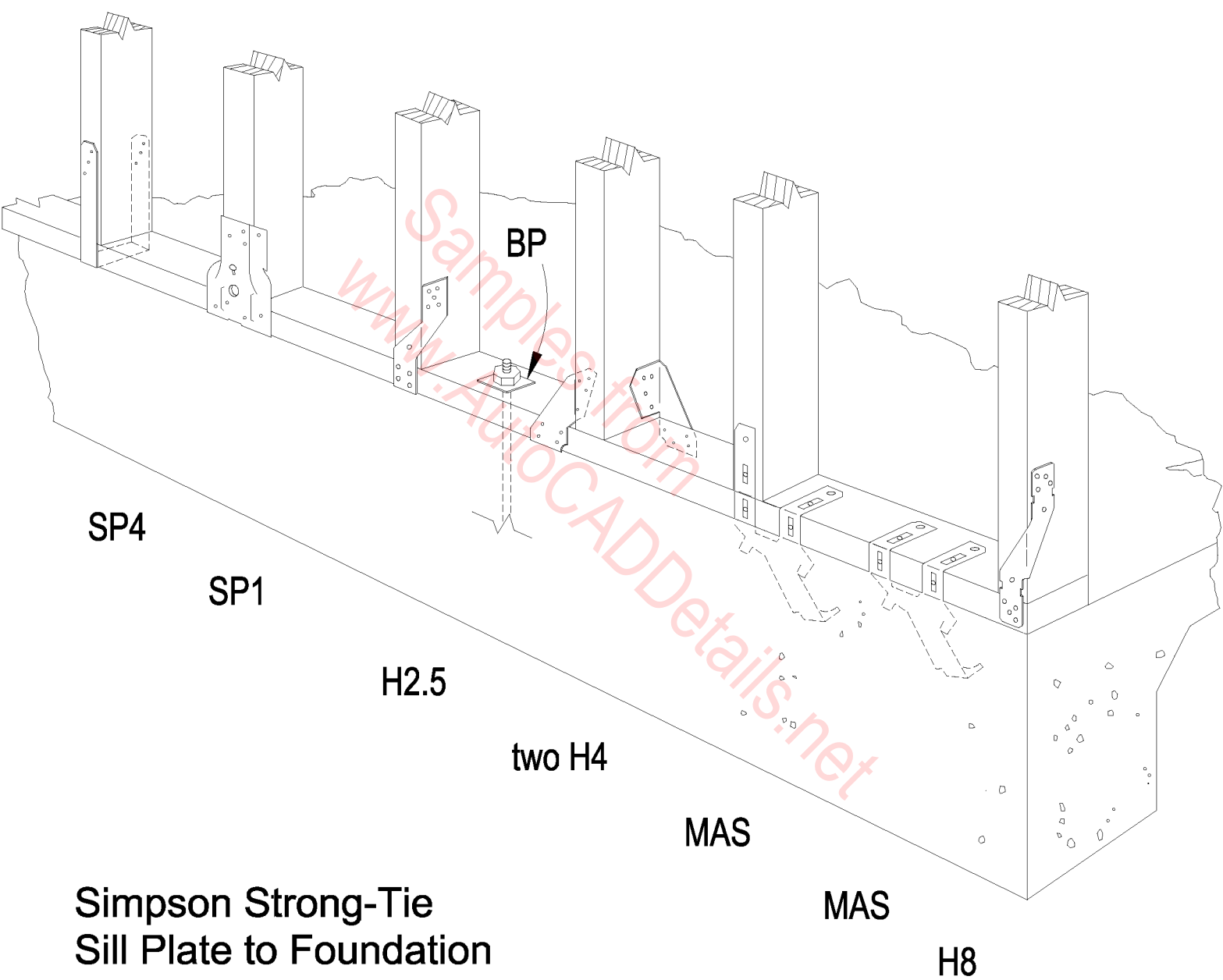

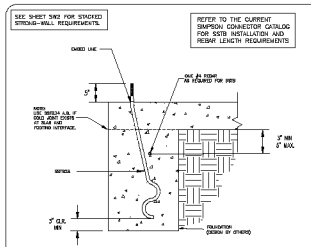

SSBT ANCHORAGE (SLAB ON GRADE) 1

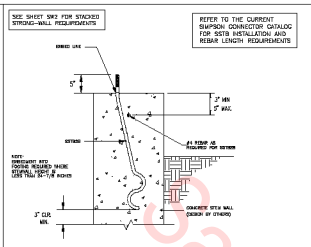

SSBT ANCHORAGE (CONC. STEM WALL) 2

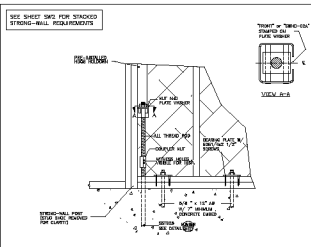

STANDARD WALL SILL 3

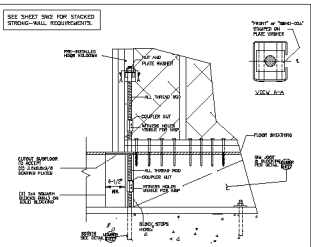

RAISED FLOOR WALL SILL 4

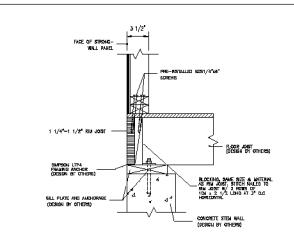

RAISED FLOOR WALL SECTION 5

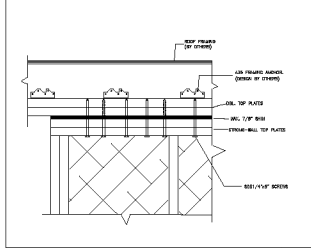

TOP PLATE CONNECTION 6



TOP PLATE CONNECTION 7



TOP PLATE CONNECTION 8

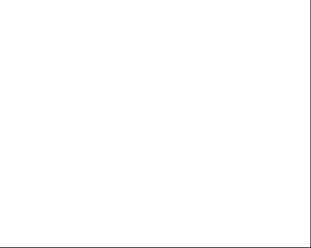

TOP PLATE CONNECTION 9



TOP PLATE CONNECTION 10

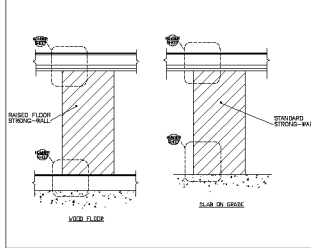

SINGLE STORY STRONG-WALL 11

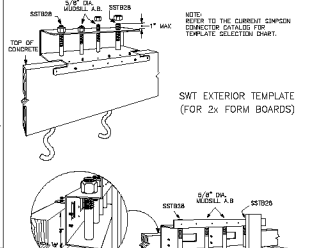

STRONG-WALL TEMPLATES 12

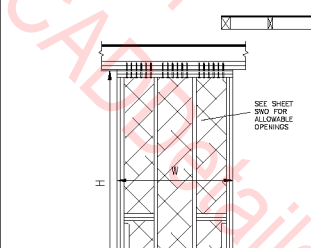

SINGLE STORY STANDARD & RAISED FLOOR WALL SPECIFICATIONS 13

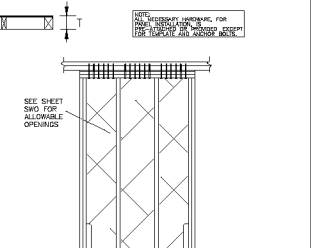

SINGLE STORY STANDARD & RAISED FLOOR WALL SPECIFICATIONS 14

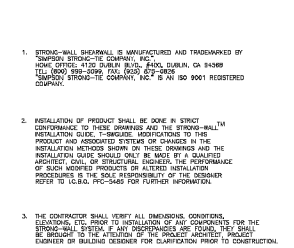

SINGLE STORY STANDARD & RAISED FLOOR WALL SPECIFICATIONS 15

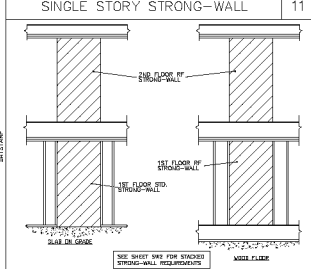

STACKED STRONG-WALL 12

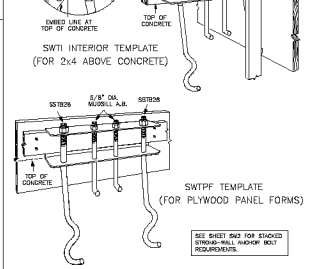

STRONG-WALL TEMPLATES 13

STANDARD STRONG-WALL MODELS

MODEL NO.	H (ft)	D (in)	NUMBER OF REBARS	MINIMUM WALL THICKNESS (in)
SW100	10	12	3-1/2"	12
SW120	12	12	3-1/2"	12
SW140	14	12	3-1/2"	12
SW160	16	12	3-1/2"	12
SW180	18	12	3-1/2"	12
SW200	20	12	3-1/2"	12
SW220	22	12	3-1/2"	12
SW240	24	12	3-1/2"	12
SW260	26	12	3-1/2"	12
SW280	28	12	3-1/2"	12
SW300	30	12	3-1/2"	12
SW320	32	12	3-1/2"	12
SW340	34	12	3-1/2"	12
SW360	36	12	3-1/2"	12
SW380	38	12	3-1/2"	12
SW400	40	12	3-1/2"	12
SW420	42	12	3-1/2"	12
SW440	44	12	3-1/2"	12
SW460	46	12	3-1/2"	12
SW480	48	12	3-1/2"	12
SW500	50	12	3-1/2"	12

RAISED FLOOR STRONG-WALL MODELS

MODEL NO.	H (ft)	D (in)	NUMBER OF REBARS	MINIMUM WALL THICKNESS (in)
SW100-RF	10	12	3-1/2"	12
SW120-RF	12	12	3-1/2"	12
SW140-RF	14	12	3-1/2"	12
SW160-RF	16	12	3-1/2"	12
SW180-RF	18	12	3-1/2"	12
SW200-RF	20	12	3-1/2"	12
SW220-RF	22	12	3-1/2"	12
SW240-RF	24	12	3-1/2"	12
SW260-RF	26	12	3-1/2"	12
SW280-RF	28	12	3-1/2"	12
SW300-RF	30	12	3-1/2"	12
SW320-RF	32	12	3-1/2"	12
SW340-RF	34	12	3-1/2"	12
SW360-RF	36	12	3-1/2"	12
SW380-RF	38	12	3-1/2"	12
SW400-RF	40	12	3-1/2"	12
SW420-RF	42	12	3-1/2"	12
SW440-RF	44	12	3-1/2"	12
SW460-RF	46	12	3-1/2"	12
SW480-RF	48	12	3-1/2"	12
SW500-RF	50	12	3-1/2"	12

- STRONG-WALL SHEARWALL IS MANUFACTURED AND TRADEMARKED BY SARGON STRONG-TEC COMPANY, INC. HOW: OFFICE: 4110 DUBLIN BLVD., DUBLIN, CA 94568 TEL: 925 835 7500 FAX: 925 835 7505 SARGON STRONG-TEC COMPANY, INC. IS AN ISO 9001 REGISTERED COMPANY.
- INSTALLATION OF PRODUCT SHALL BE DONE IN STRICT CONFORMANCE TO THESE DRAWINGS AND THE STRONG-WALL<sup>TM</sup> INSTALLATION GUIDE. FUTURE MODIFICATIONS TO THIS PRODUCT AND ASSOCIATED SYSTEMS OR CHANGES IN THE INSTALLATION APPROX SHOWN OR THESE DRAWINGS AND THE INSTALLATION GUIDE SHOULD ONLY BE MADE BY A QUALIFIED ARCHITECT OR STRUCTURAL ENGINEER. THE PERFORMANCE OF SUCH MODIFICATIONS IS NOT GUARANTEED. THE RESPONSIBILITY OF SUCH MODIFICATIONS IS THE SOLE RESPONSIBILITY OF THE DESIGNER. REFER TO USBA-PRO-5469 FOR FURTHER INFORMATION.
- THE CONTRACTOR SHALL VERIFY ALL DIMENSIONS, CONDITIONS, ELEVATIONS, ETC. PRIOR TO INSTALLATION OF ALL COMPONENTS FOR THE STRONG-WALL SYSTEM. IF ANY DISCREPANCIES ARE FOUND, THEY SHALL BE BROUGHT TO THE ATTENTION OF THE PROJECT ARCHITECT PRIOR TO BEGINNING OF BUILDING. REVISIONS FOR CLARIFICATION PRIOR TO CONSTRUCTION.
- THE CONTRACTOR SHALL VERIFY THE POSITION OF THE STRONG-WALL IN RELATION TO THE REST OF THE BUILDING SYSTEM AS SHOWN ON THE PROJECT DRAWINGS.
- USE OF THIS PRODUCT IS SUBJECT TO THE APPROVAL OF THE LOCAL BUILDING OFFICIAL.
- THE BUILDING STRUCTURE SHALL BE DESIGNED IN ACCORDANCE WITH THE LATEST ADOPTED VERSION OF THE UNIFORM BUILDING CODE AND ANY OTHER LOCAL, STATE OR FEDERAL REQUIREMENTS THAT MAY APPLY. VERIFY DESIGN REQUIREMENTS WITH THE LOCAL BUILDING OFFICIALS.
- THIS PRODUCT IS PART OF THE OVERALL LATERAL FORCE RESISTING SYSTEM OF THE STRUCTURE. DESIGN OF THE BUILDING'S LATERAL FORCE RESISTING SYSTEM INCLUDES A COMPLETE LOAD PATH NECESSARY TO TRANSFER LATERAL FORCES FROM THE STRUCTURE TO THE GROUND. IT IS THE RESPONSIBILITY OF THE DESIGNER.
- ALL HARDWARE CALLED OUT IS SARGON STRONG-TEC.

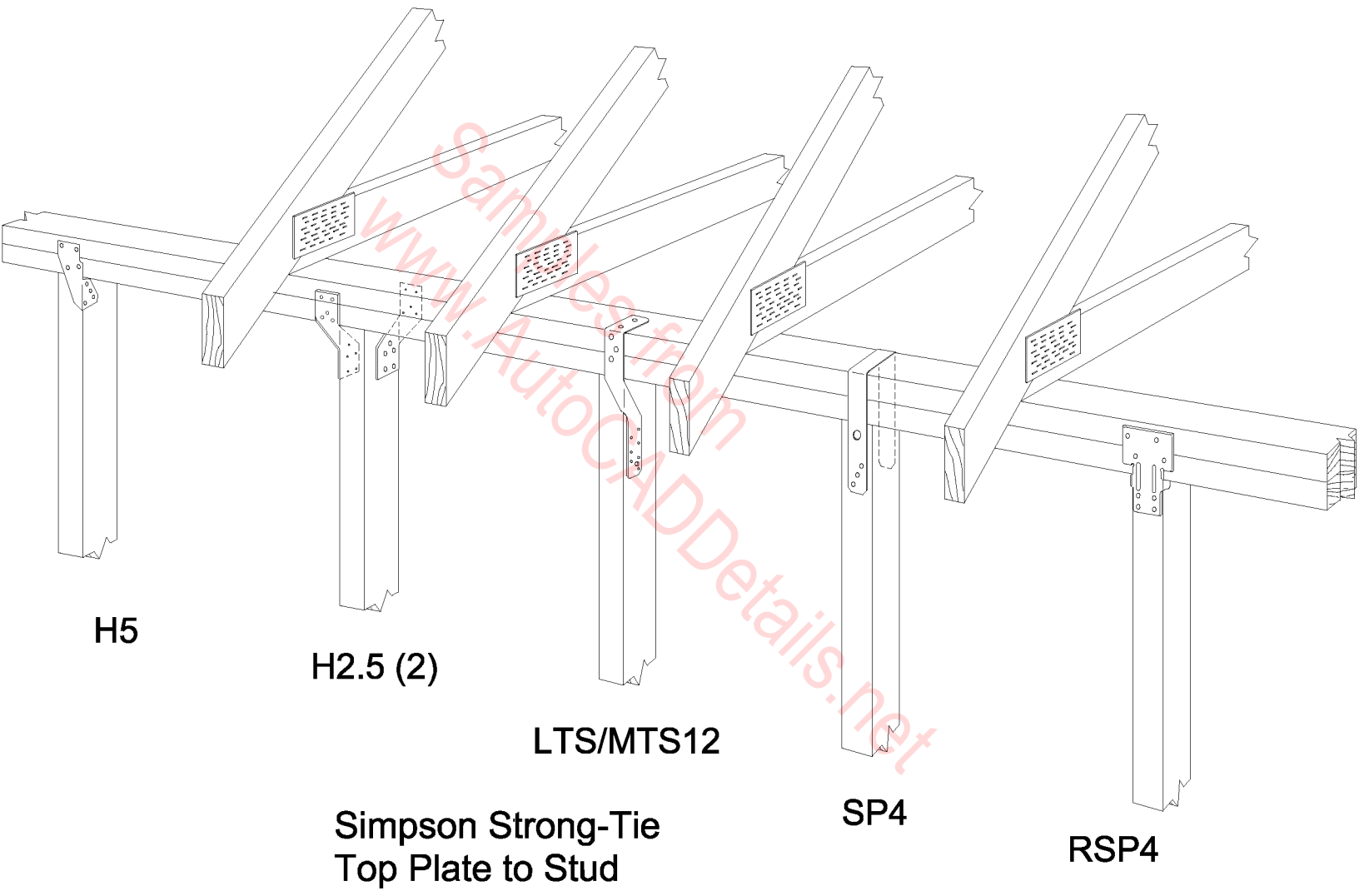

H5

H2.5 (2)

LTS/MTS12

SP4

RSP4

Simpson Strong-Tie  
Top Plate to Stud

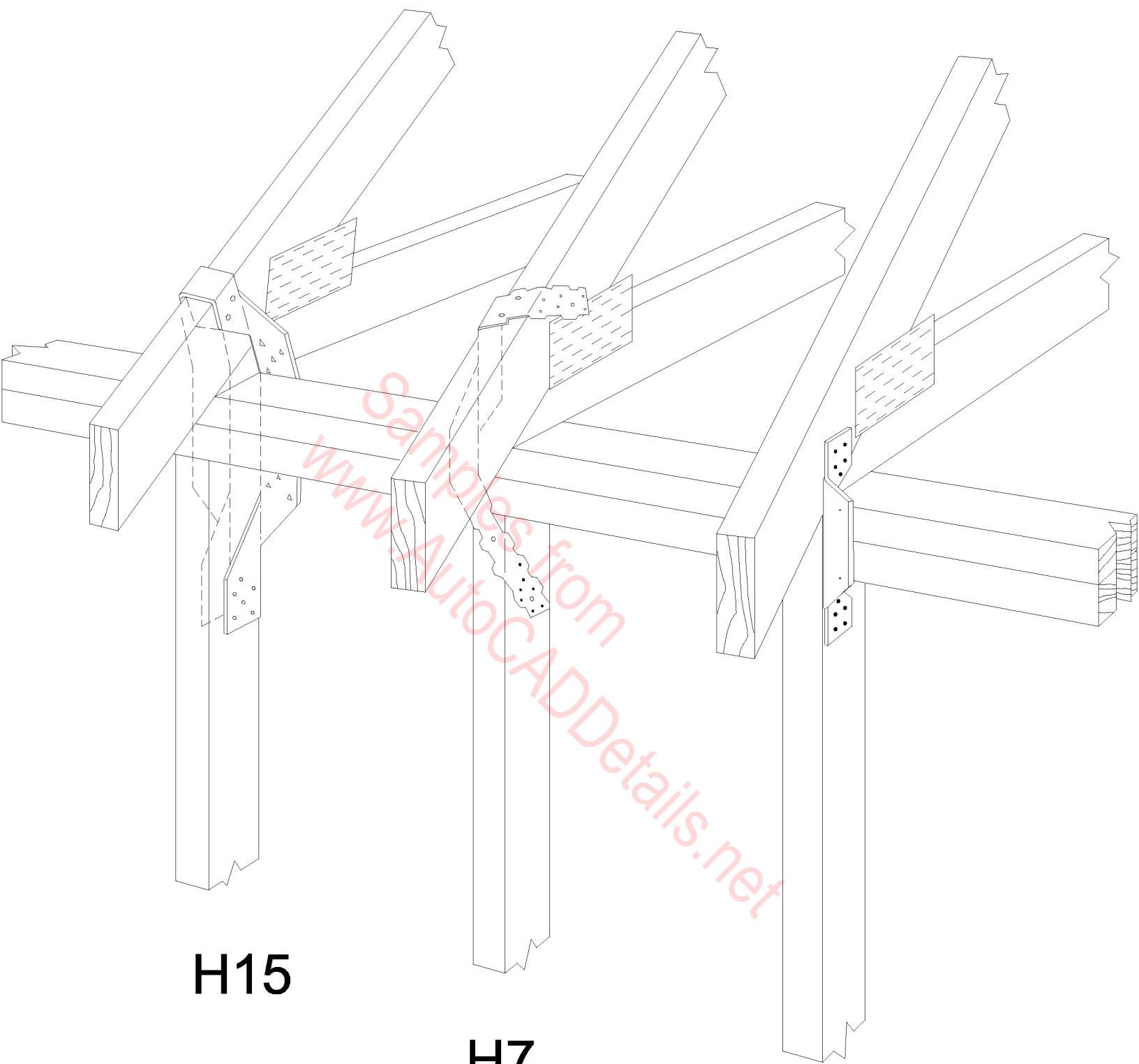

**H15**

**H7**

**H2**

**Simpson Strong-Tie  
Top Plate to Stud**

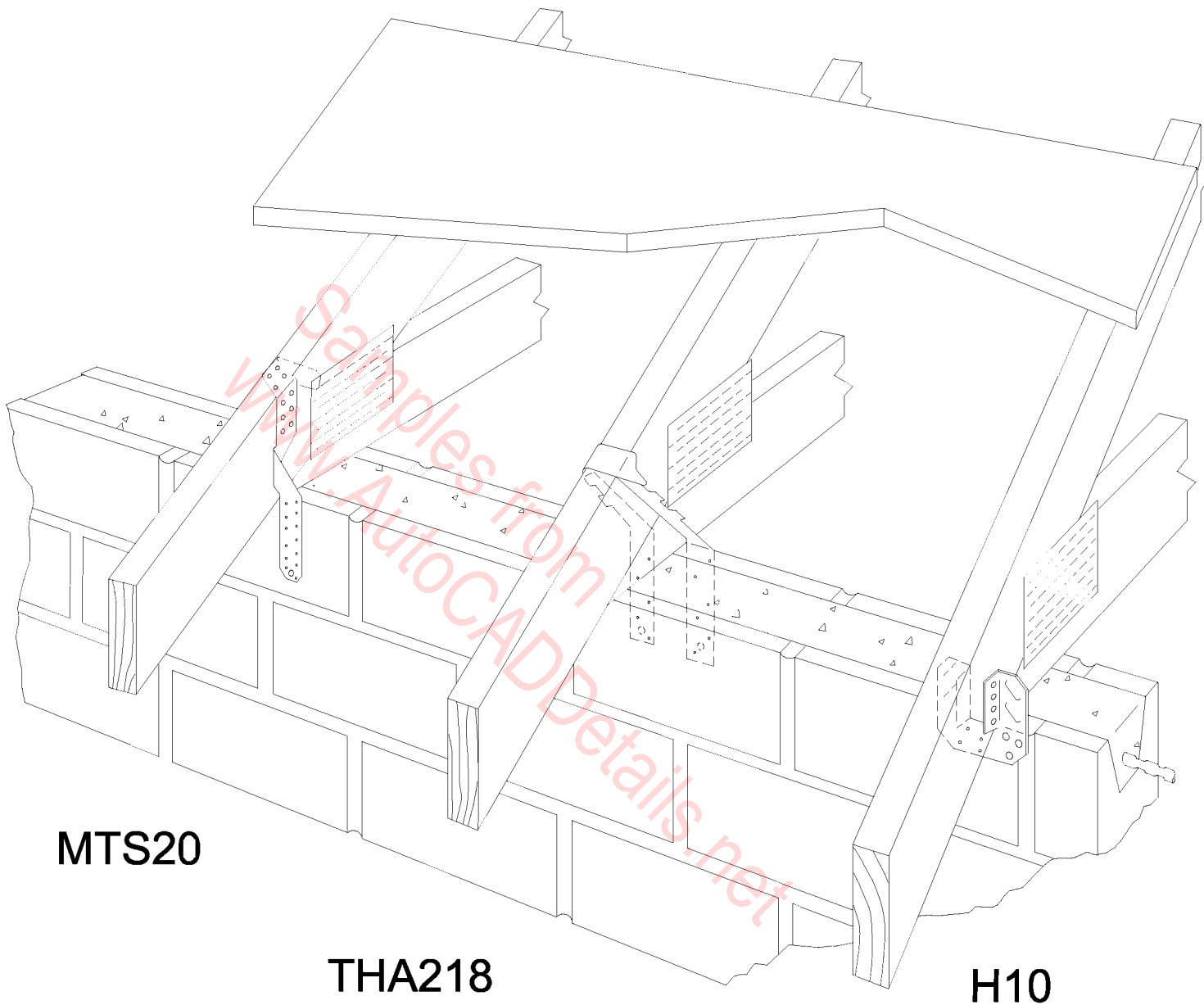

# Simpson Strong-Tie Truss and Rafter Connections to Masonry/Concrete

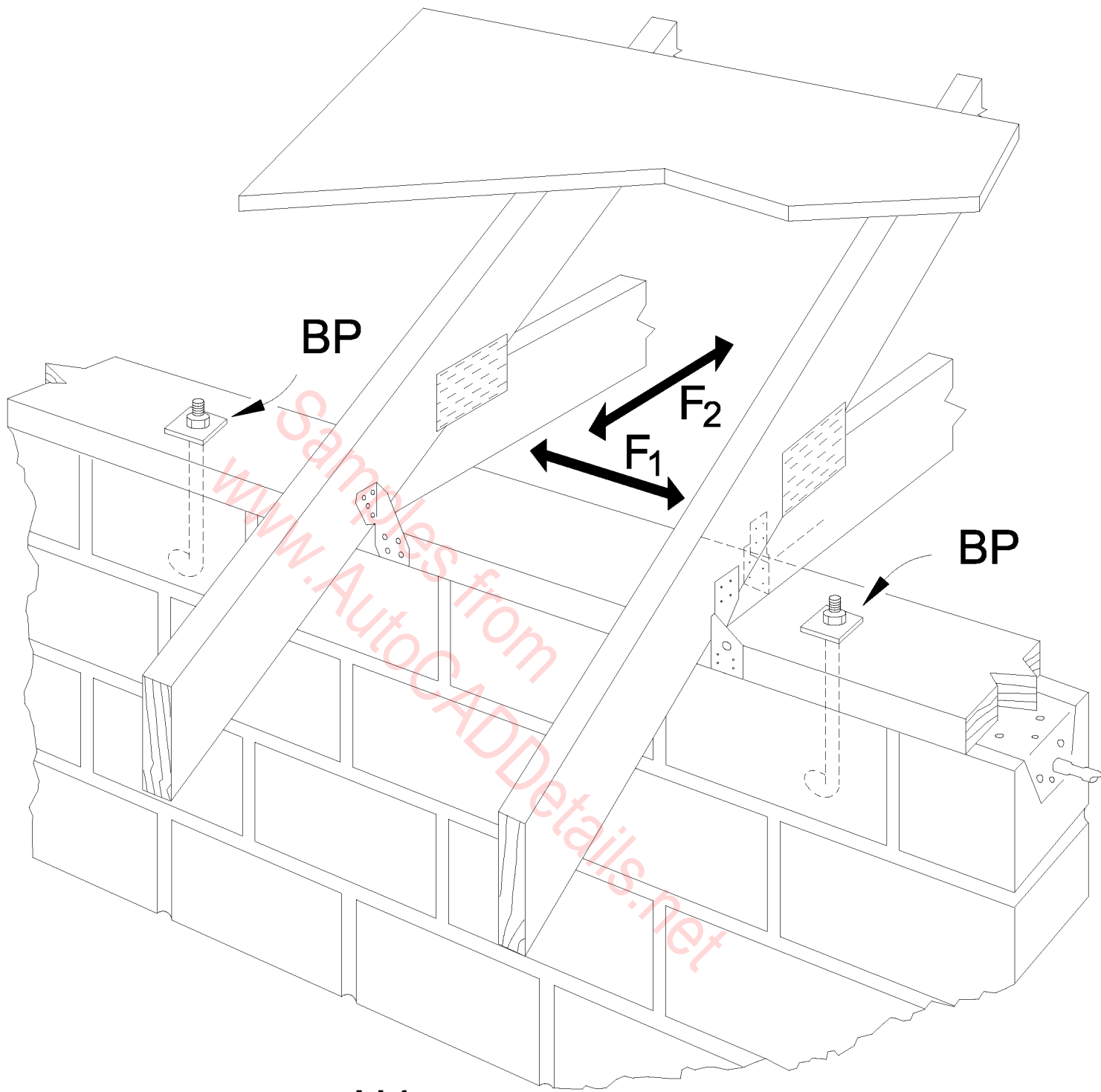

H4

Two H3

Simpson Strong-Tie  
Truss/Rafter to  
CMU Single Top Plate

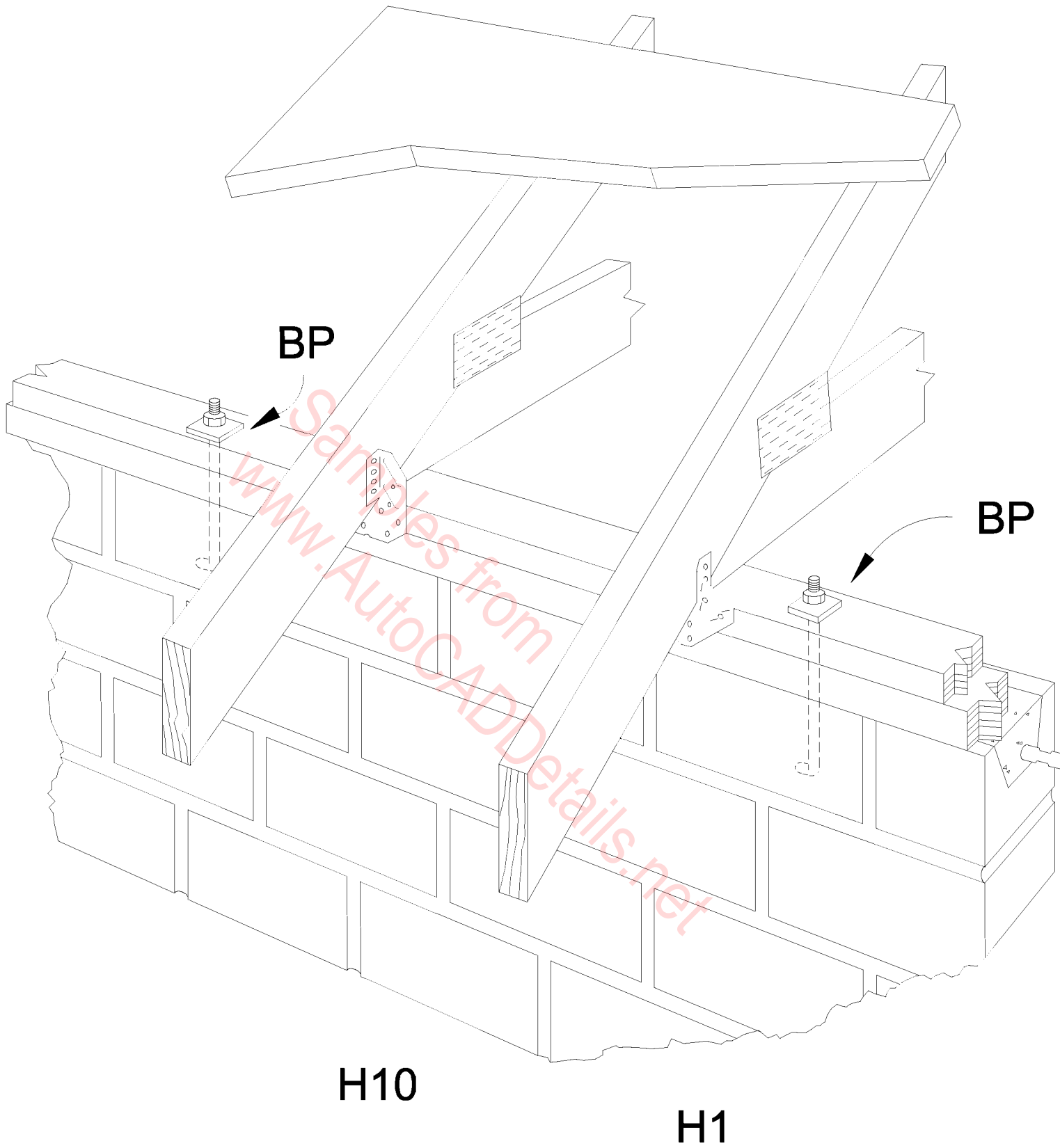

**Simpson Strong-Tie  
Truss/Rafter to  
CMU Single Top Plate**



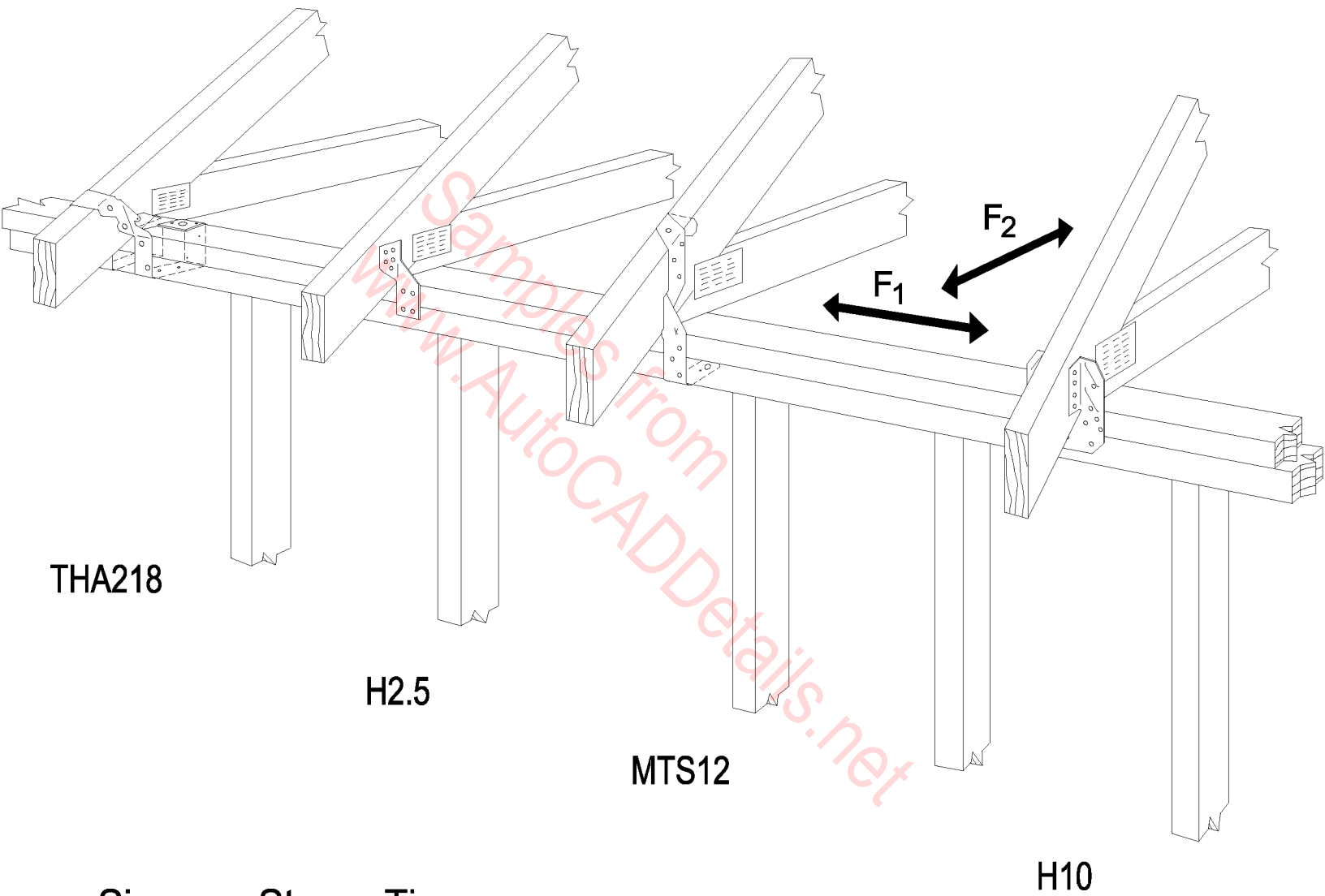

Simpson Strong-Tie  
Truss and Rafter Connections to Wood Top Plates

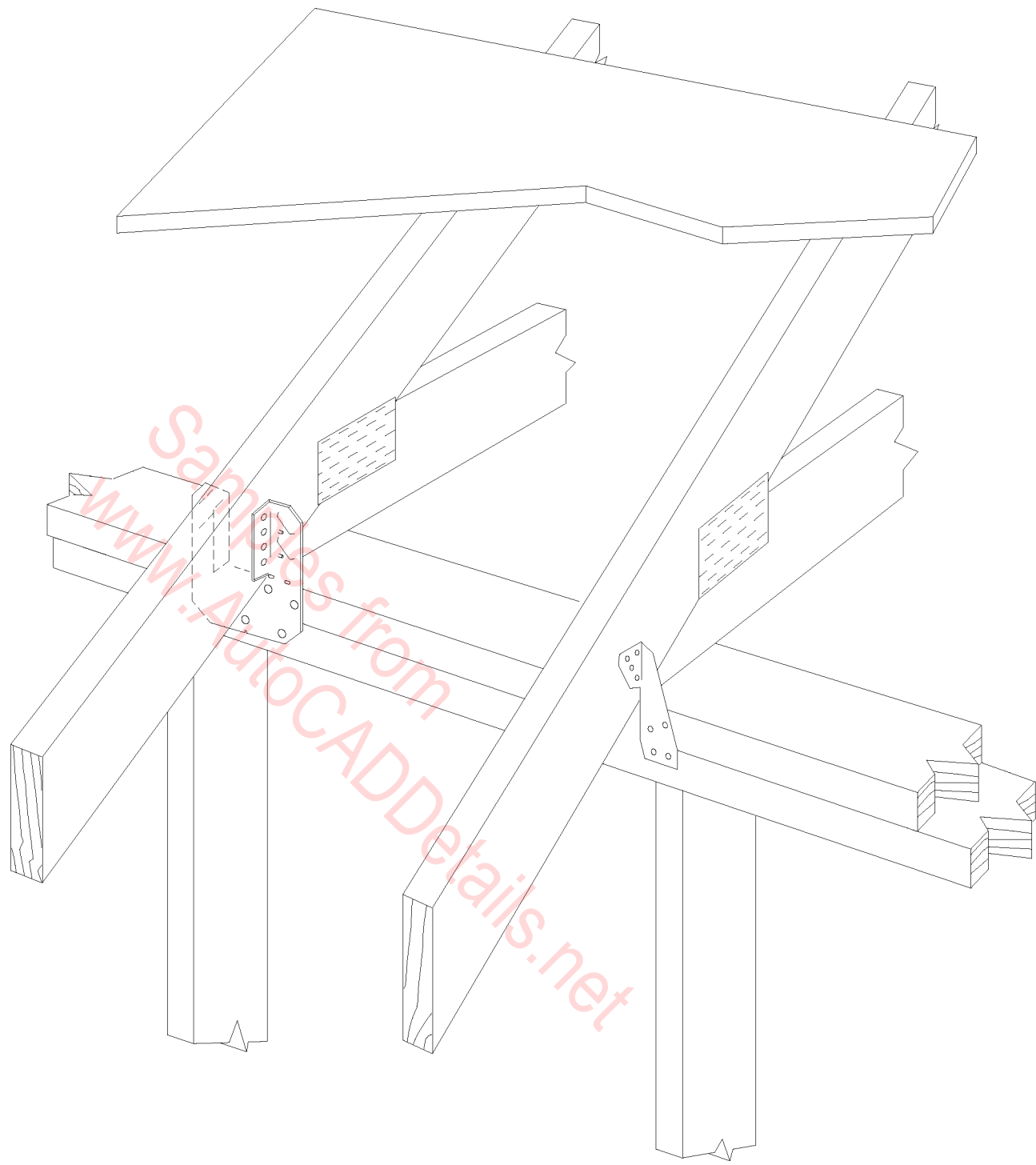

H10

H2.5

**Simpson Strong-Tie  
Truss and Rafter Connections to Wood Top Plates**

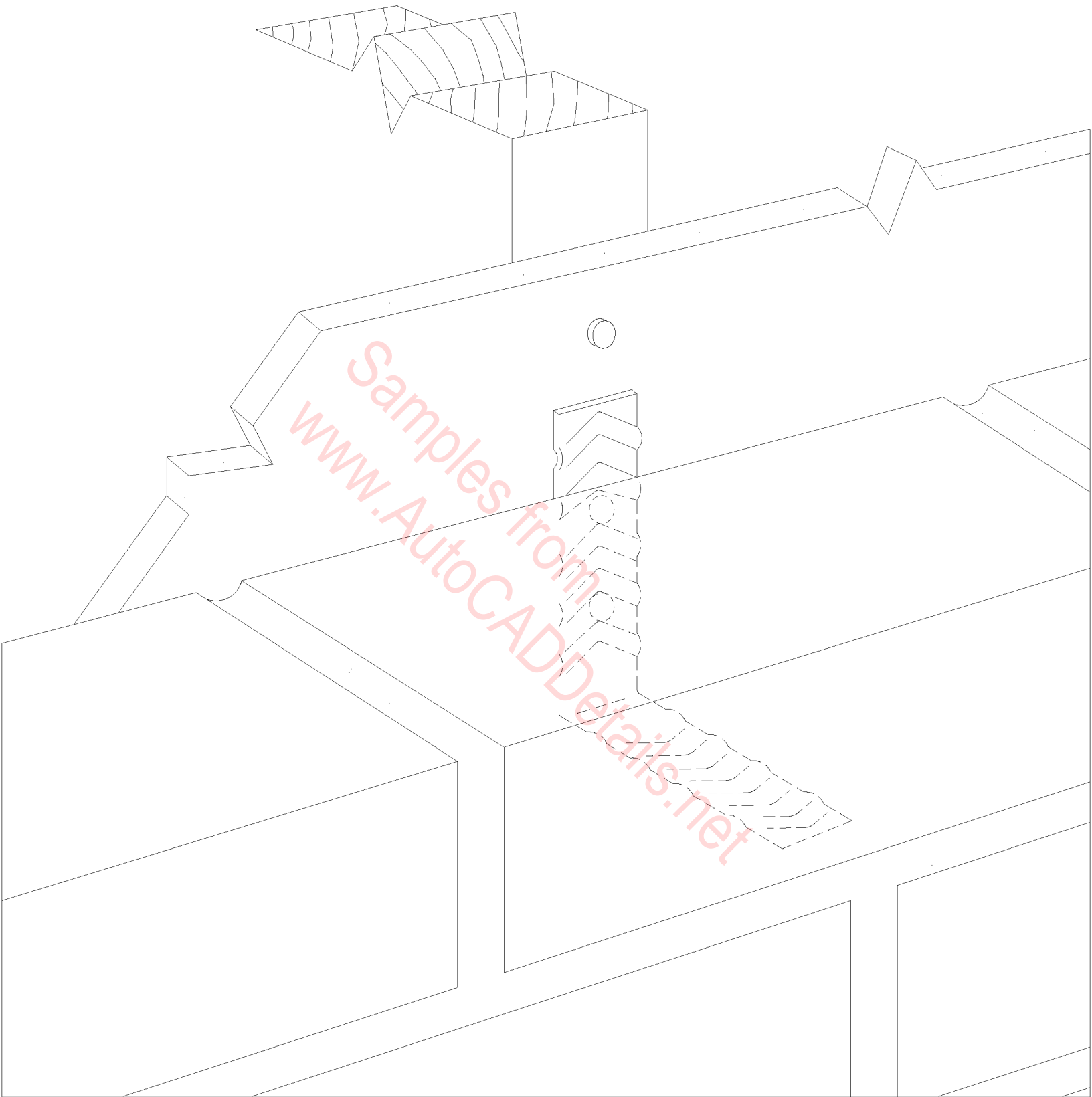

Simpson Strong-Tie  
BT

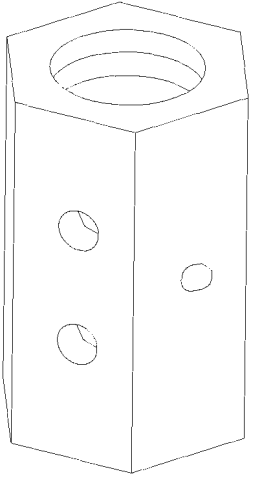

Samples from  
[www.AutoCADDetails.net](http://www.AutoCADDetails.net)

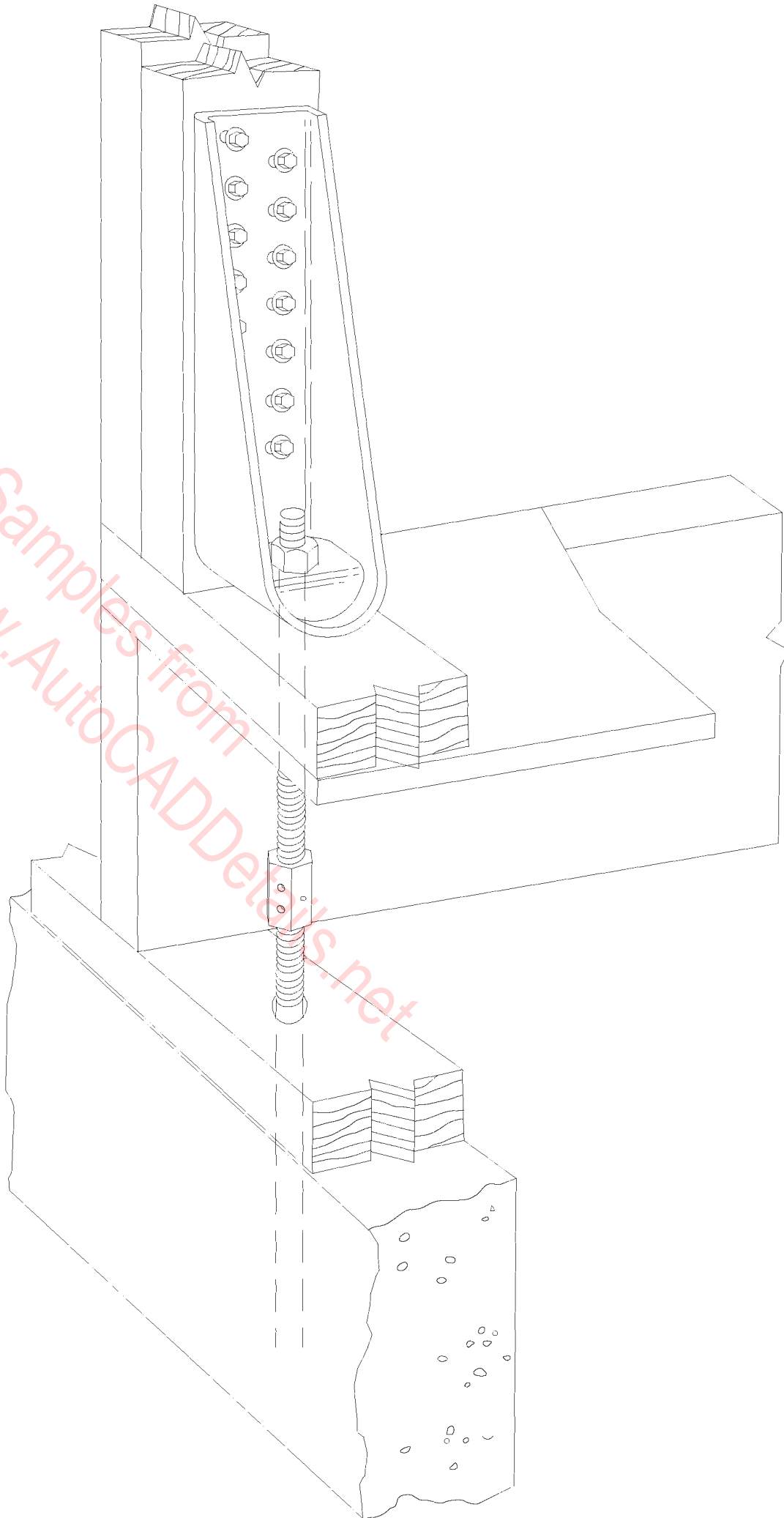

Simpson Strong-Tie  
CNW

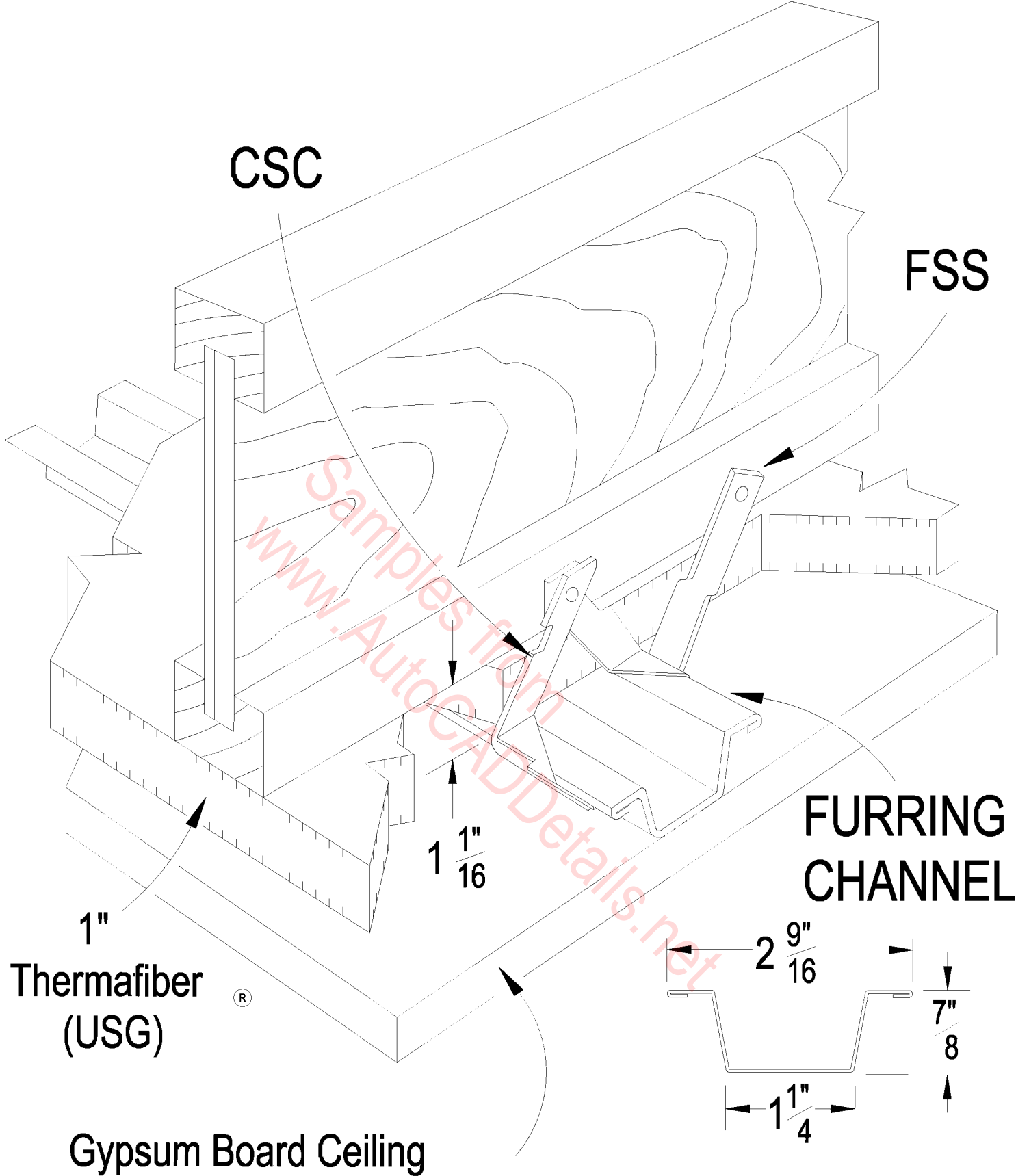

**CSC- Ceiling Support Clip  
Installed with FSS on Wood Web Joist**

**Simpson Strong-Tie  
CSC**

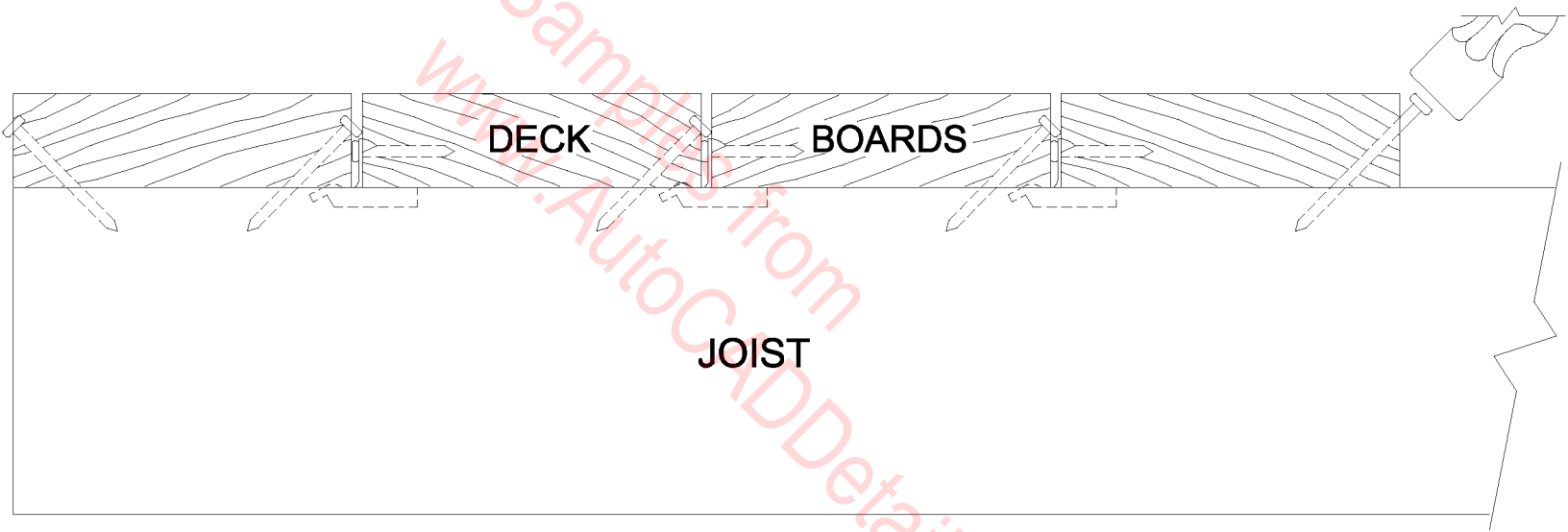

Simpson Strong-Tie  
DBT1

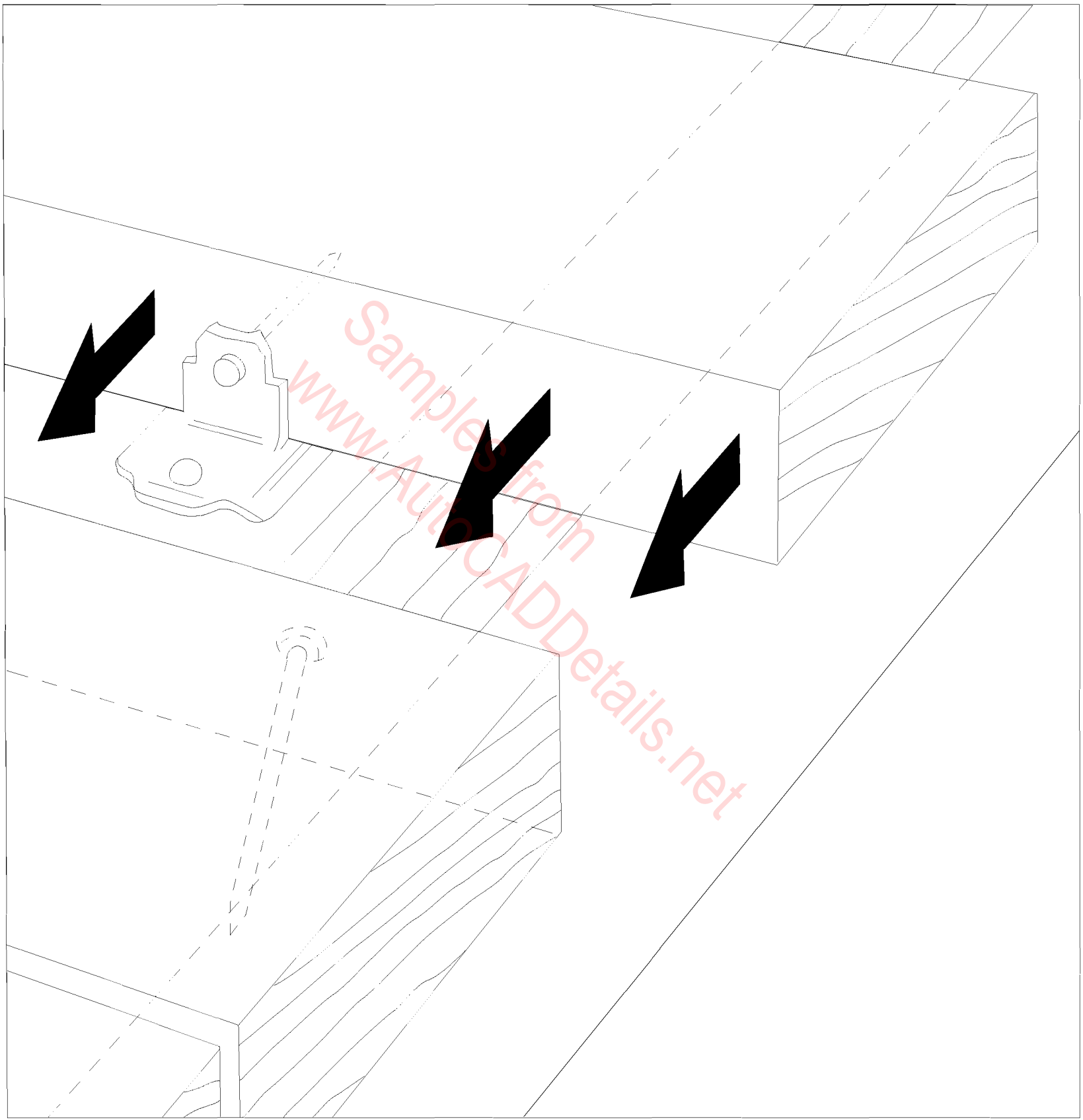

Samples from  
[www.AutocADDDetails.net](http://www.AutocADDDetails.net)

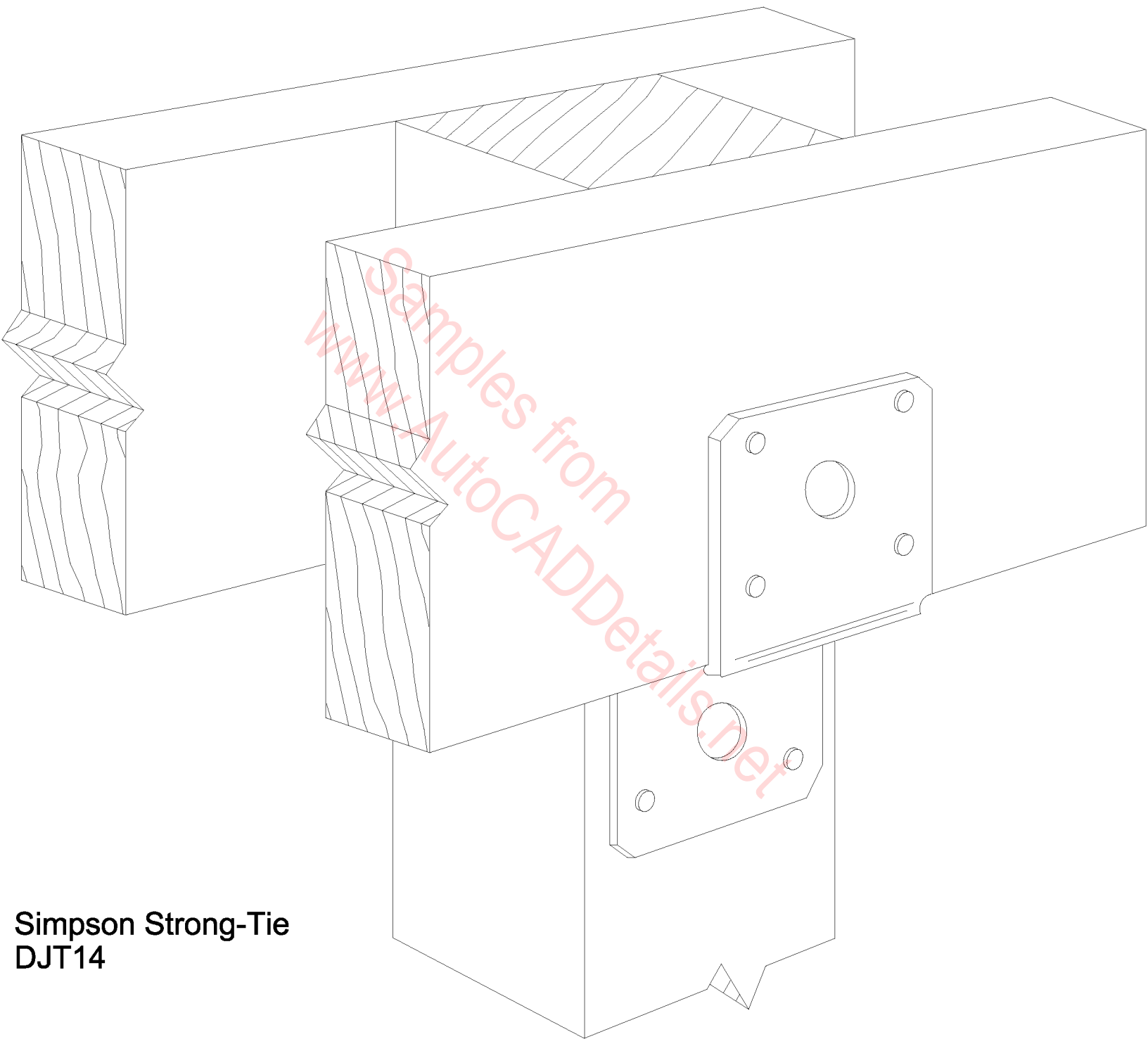

**Simpson Strong-Tie  
DJT14**



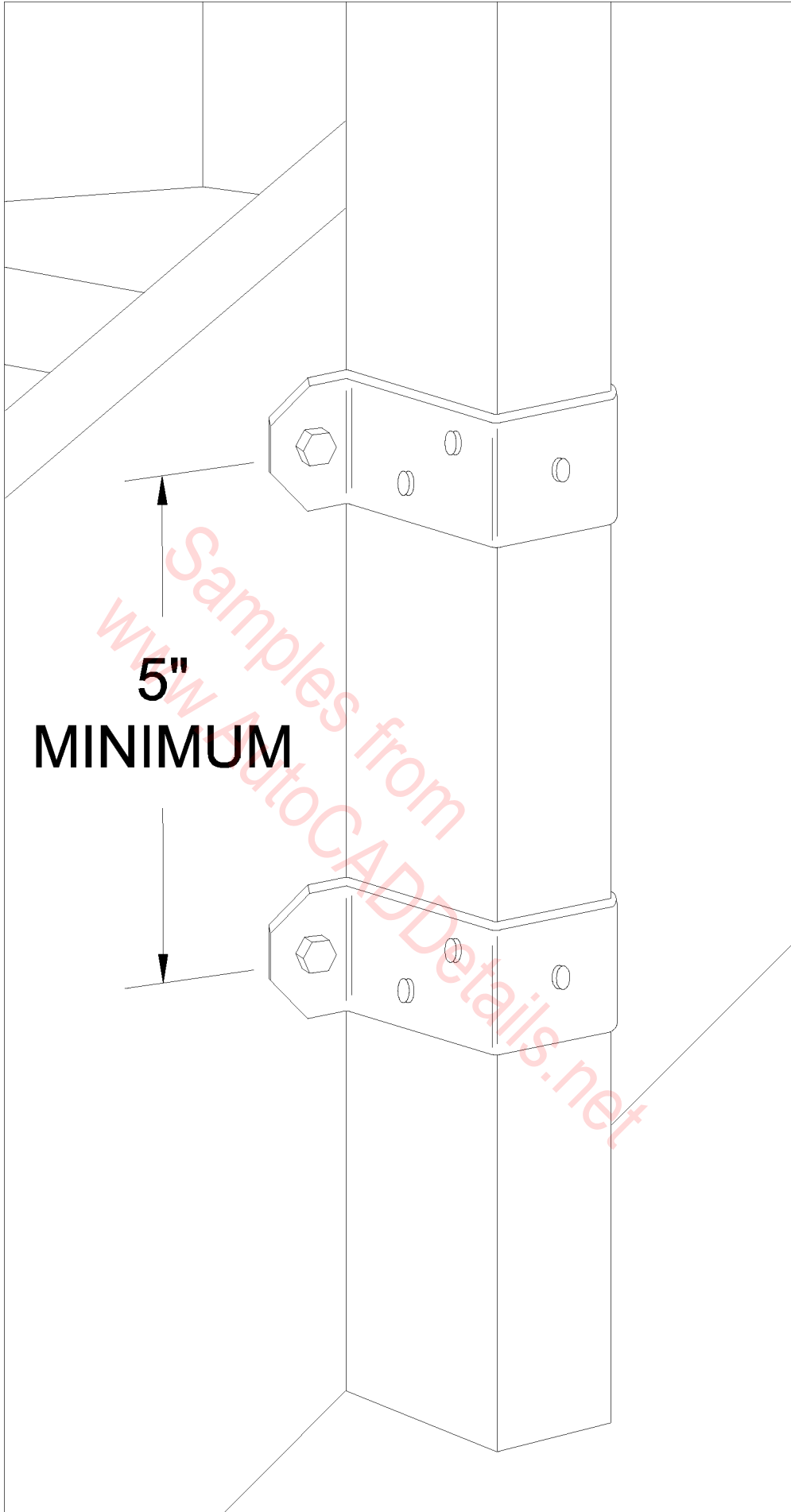

**Simpson Strong-Tie  
DPT5**

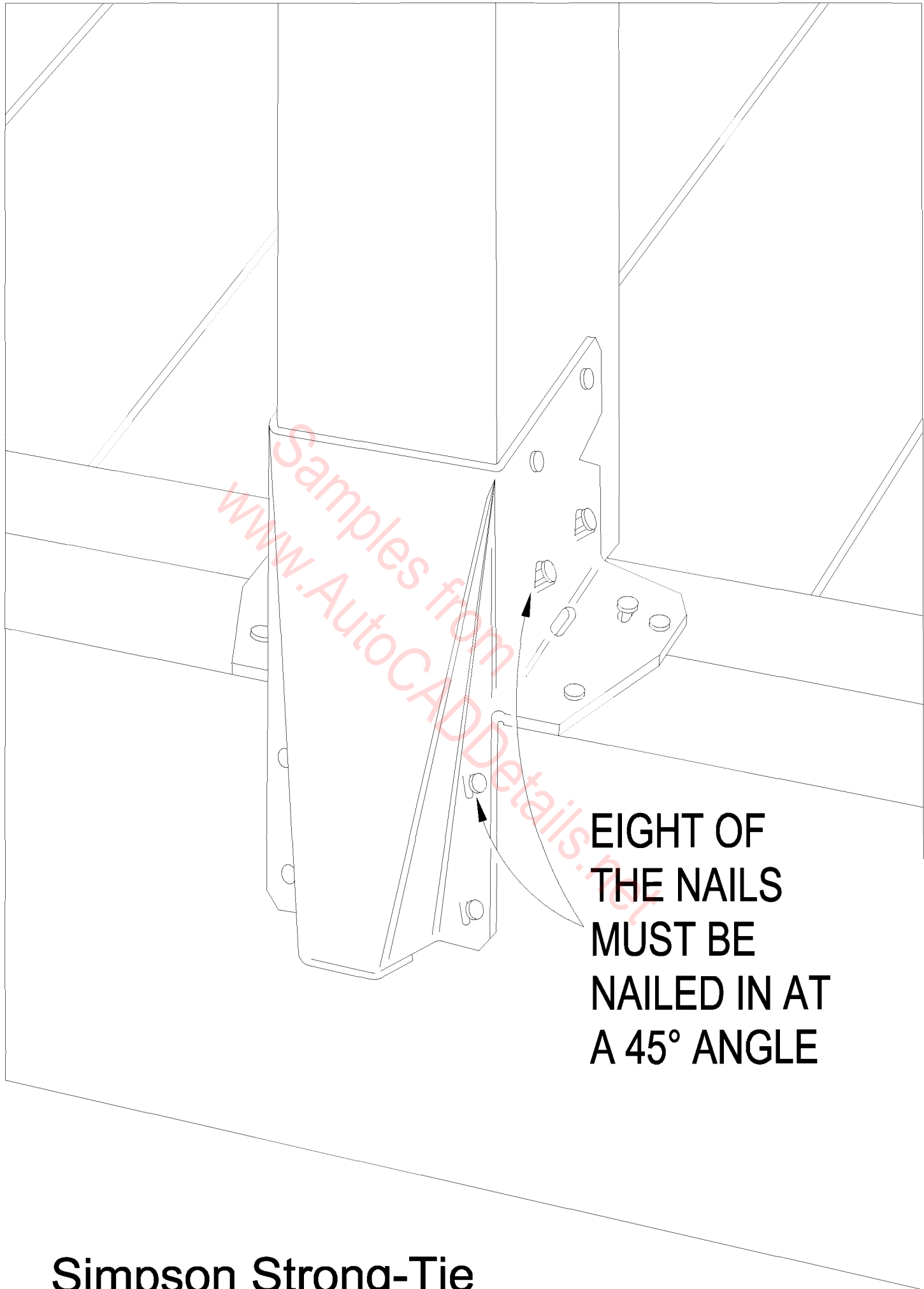

**EIGHT OF  
THE NAILS  
MUST BE  
NAILED IN AT  
A 45° ANGLE**

**Simpson Strong-Tie  
DPT6**

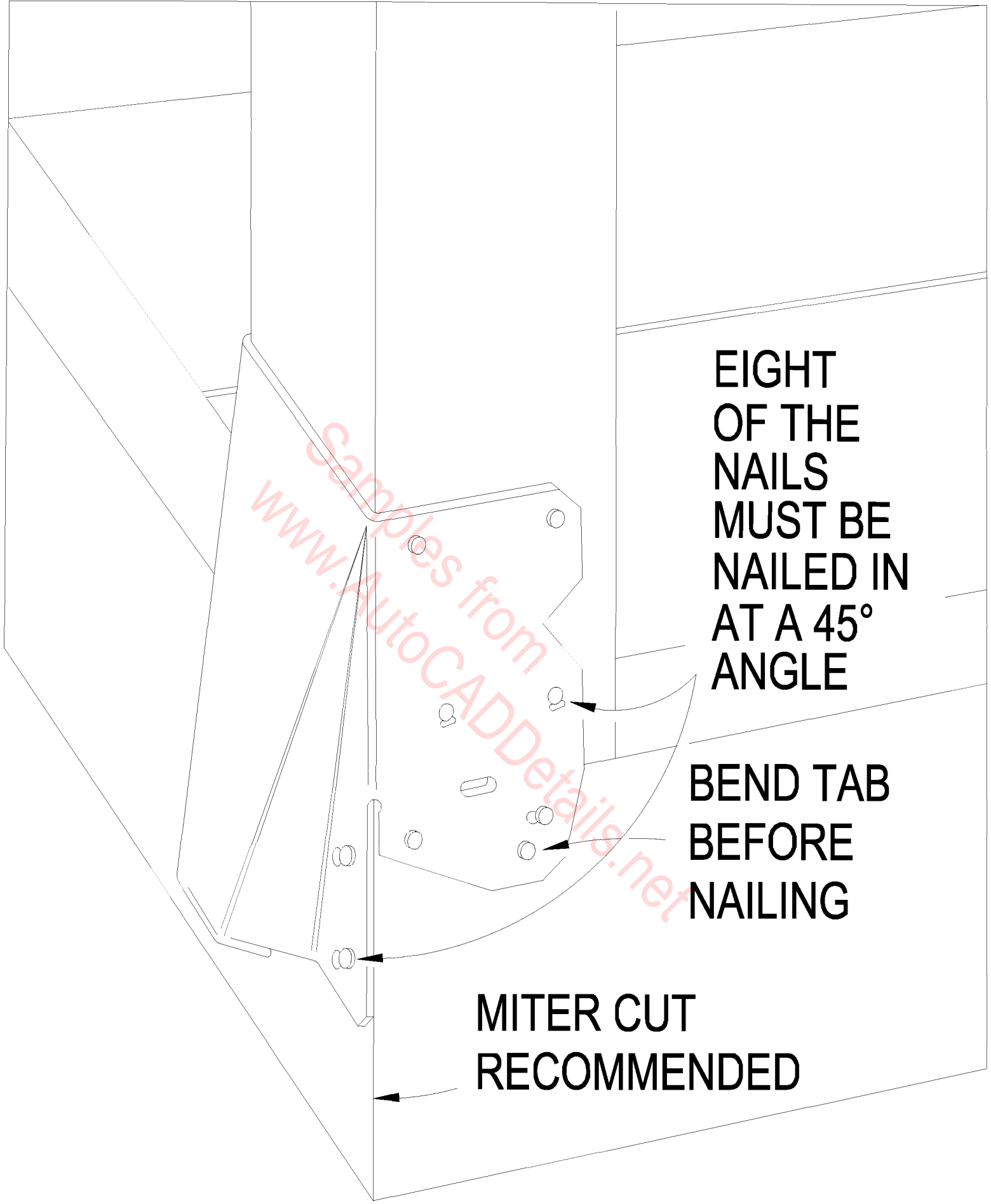

**EIGHT  
OF THE  
NAILS  
MUST BE  
NAILED IN  
AT A 45°  
ANGLE**

**BEND TAB  
BEFORE  
NAILING**

**MITER CUT  
RECOMMENDED**

**Simpson Strong-Tie  
DPT6**

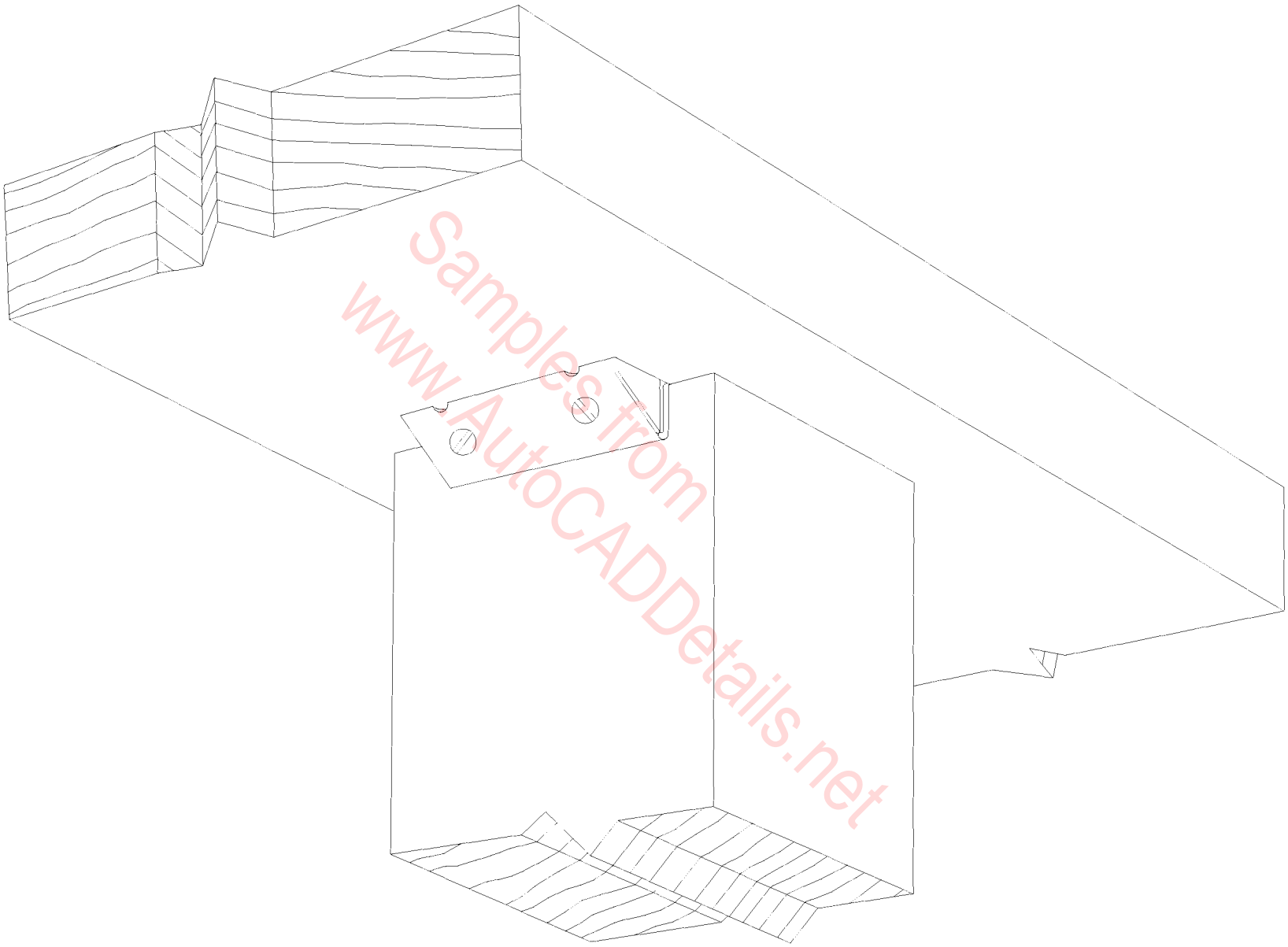

**Simpson Strong-Tie  
DRT8**

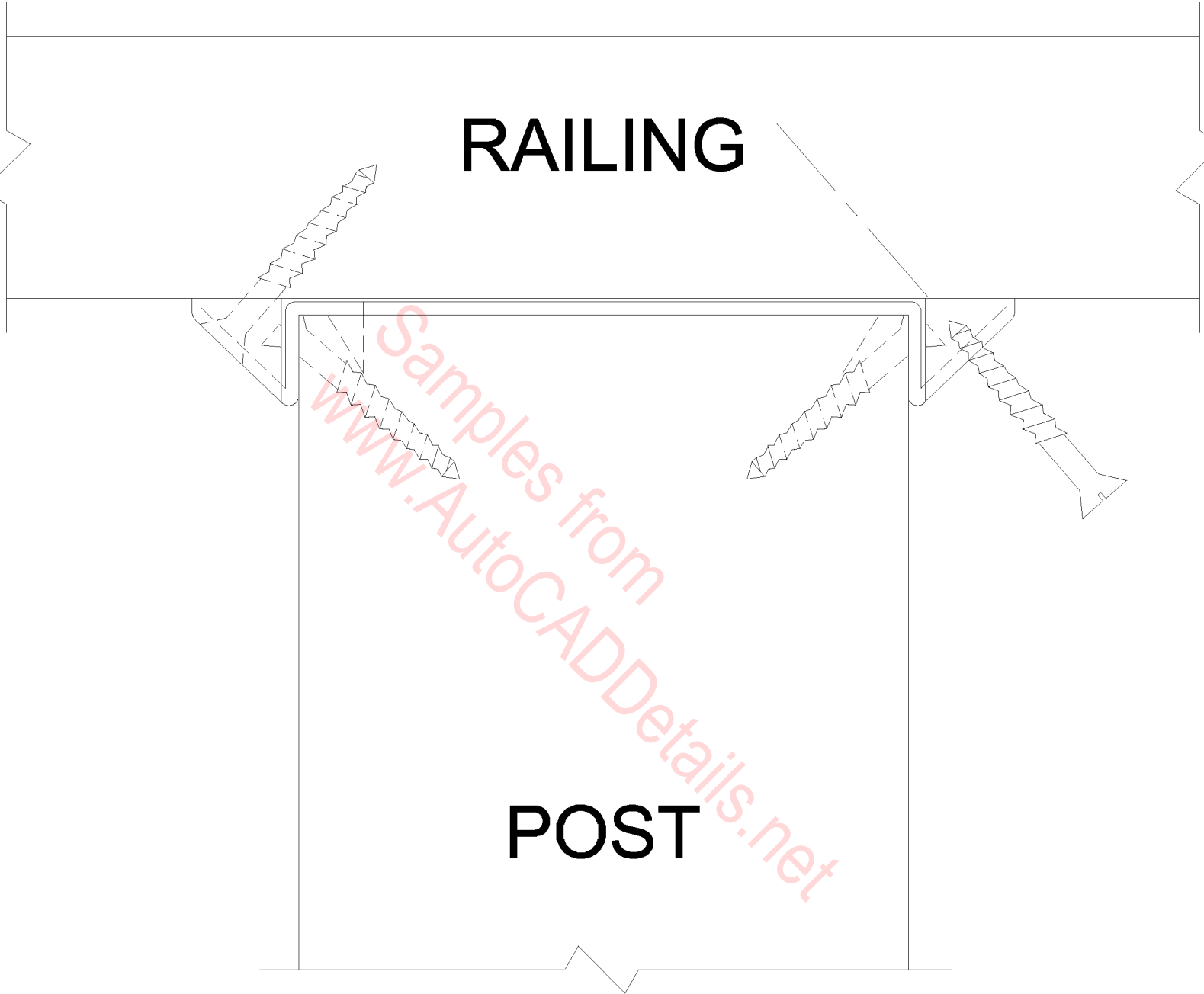

**Simpson Strong-Tie  
DRT8**

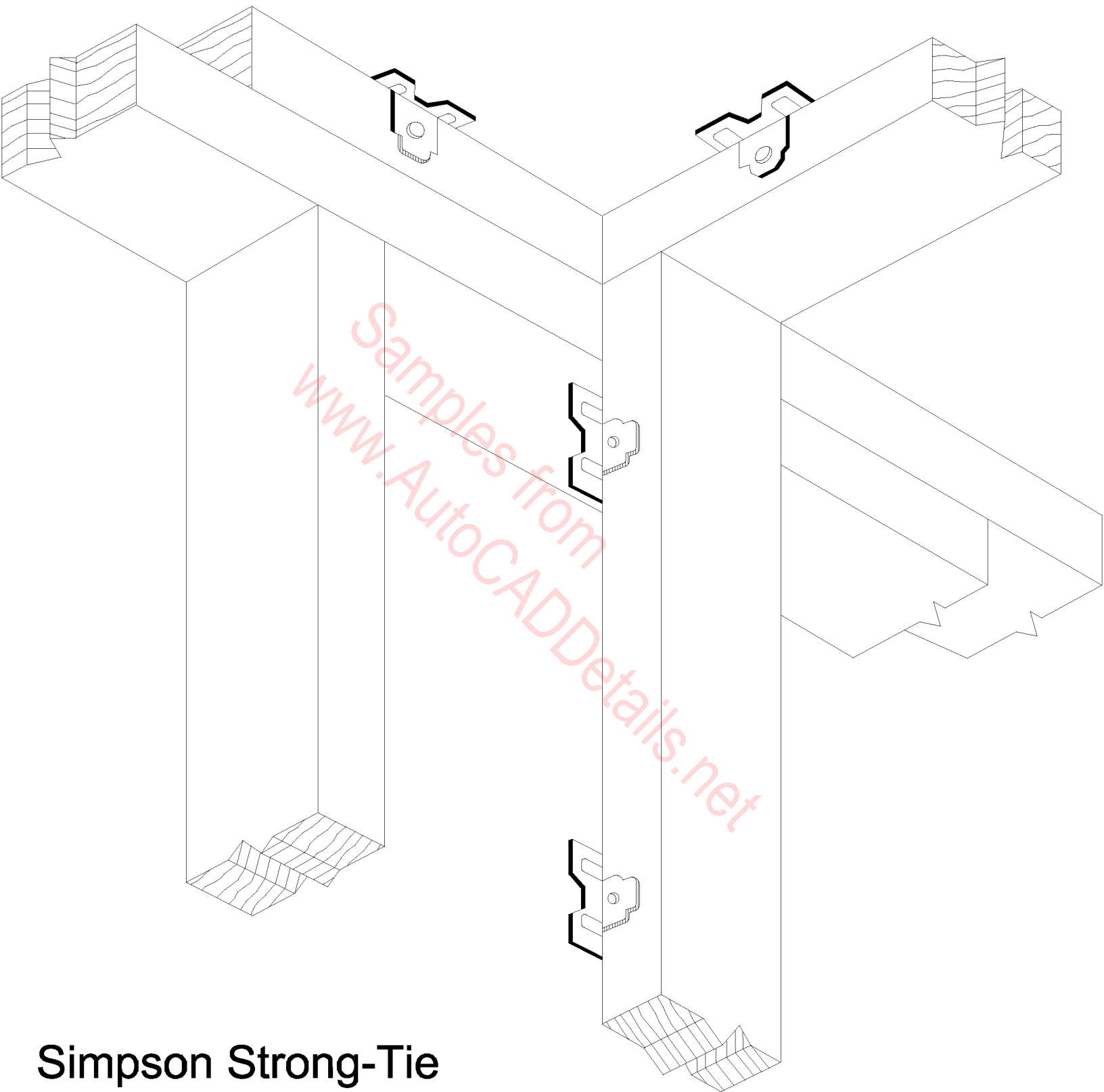

**Simpson Strong-Tie  
DS**

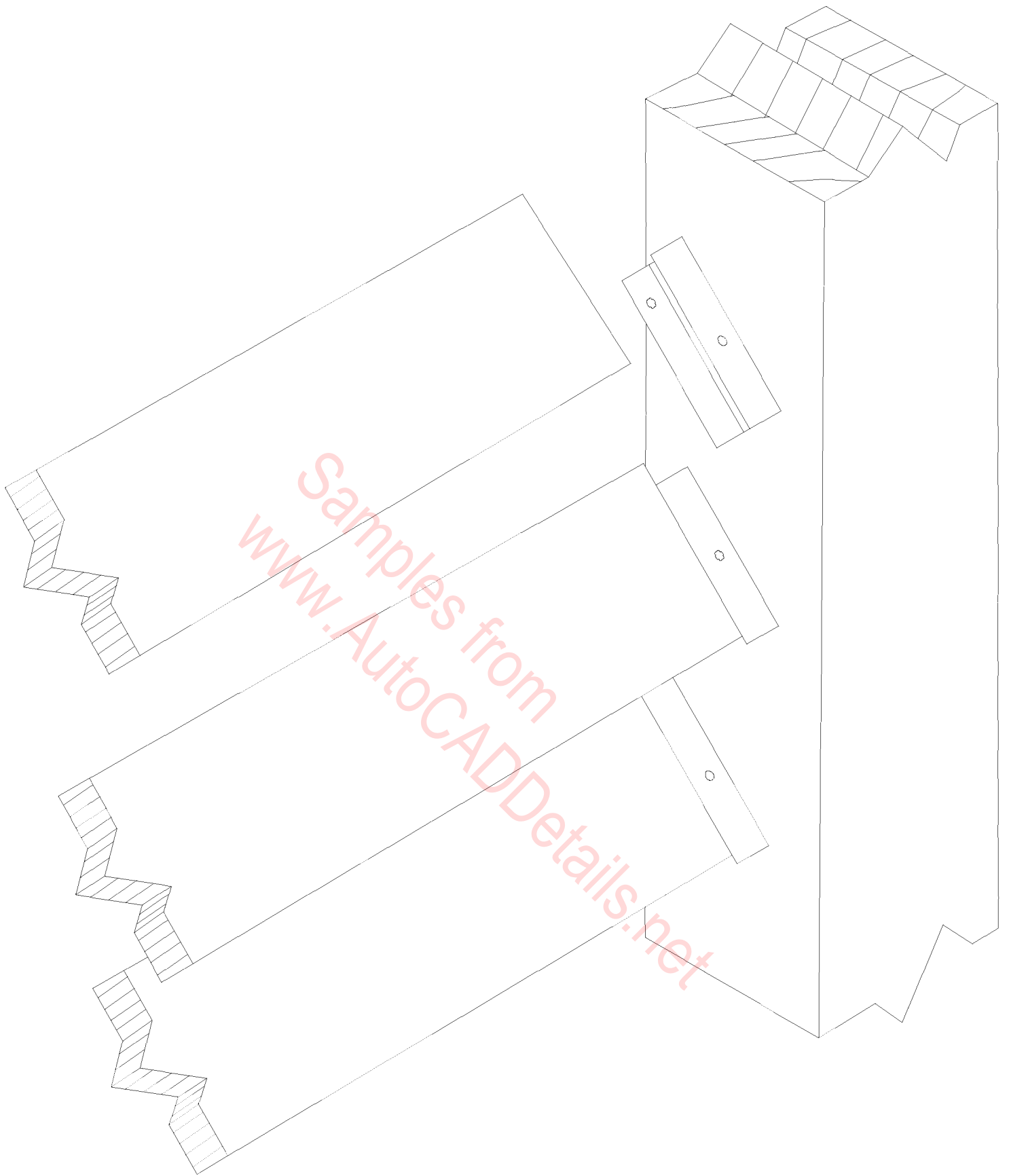

Samples from  
[www.AutoCADDetails.net](http://www.AutoCADDetails.net)

# Simpson Strong-Tie FB

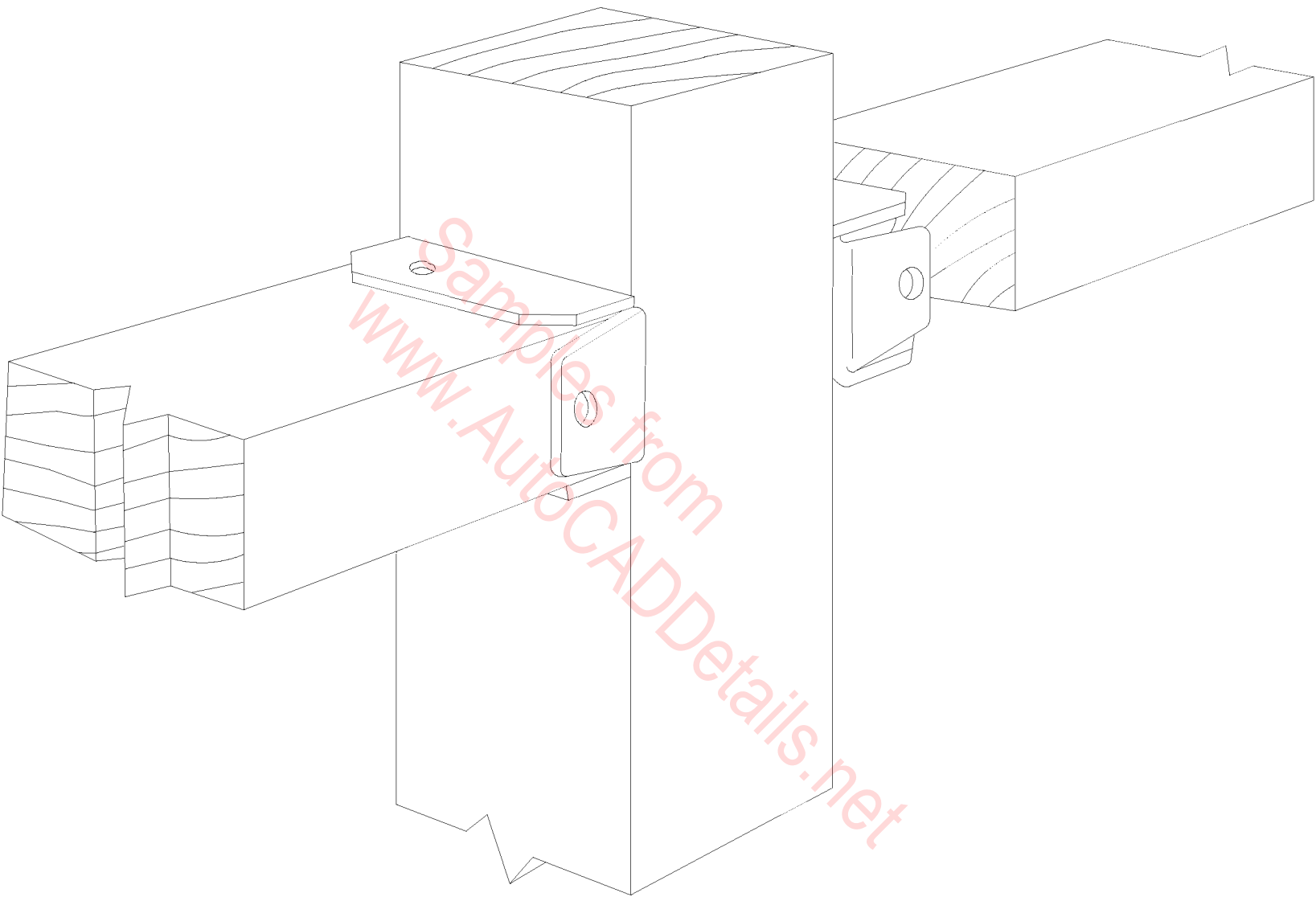

**Simpson Strong-Tie  
FB24**



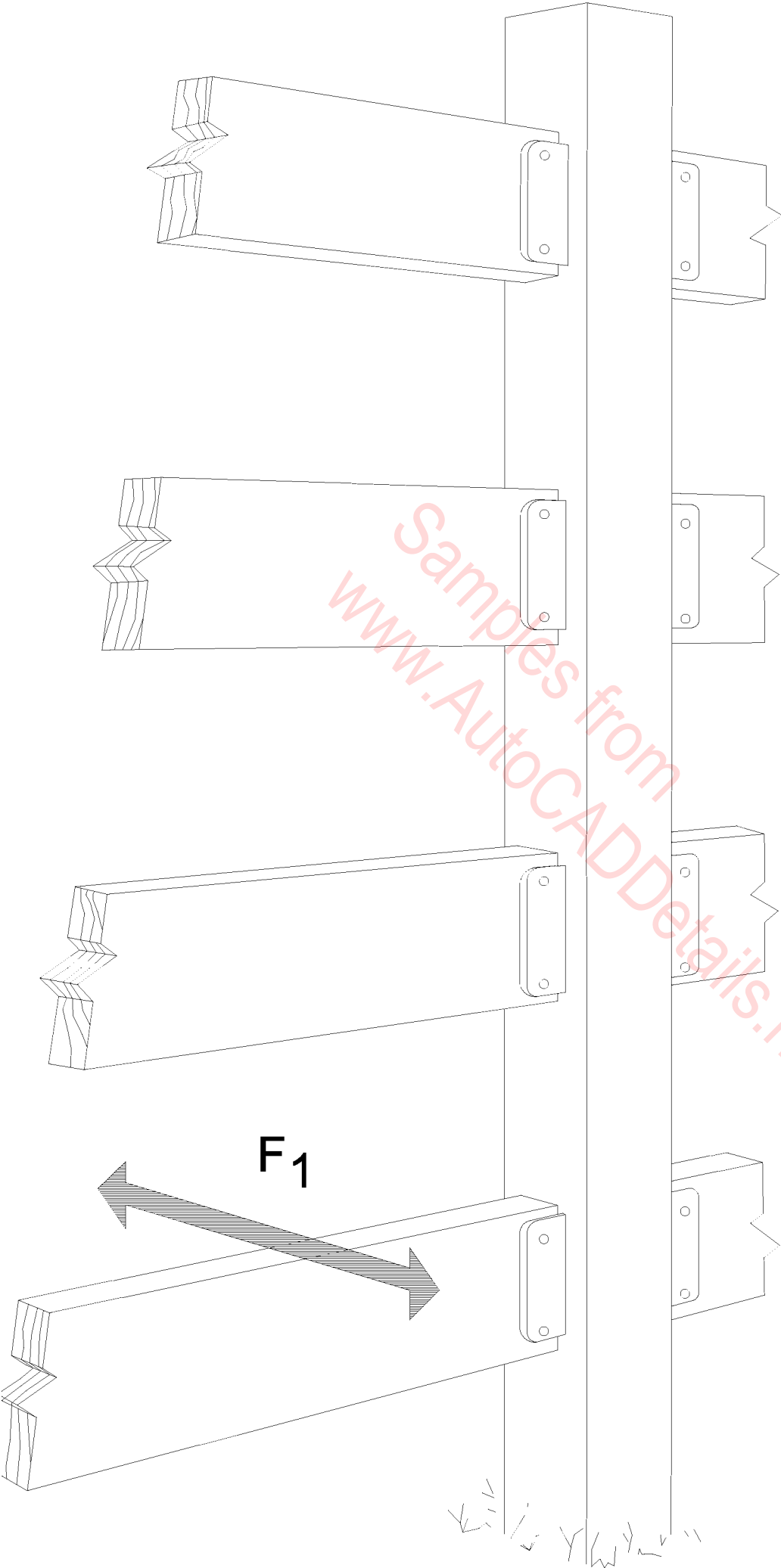

**Simpson Strong-Tie  
FB26  
Installation Attaching  
Rails to Post**

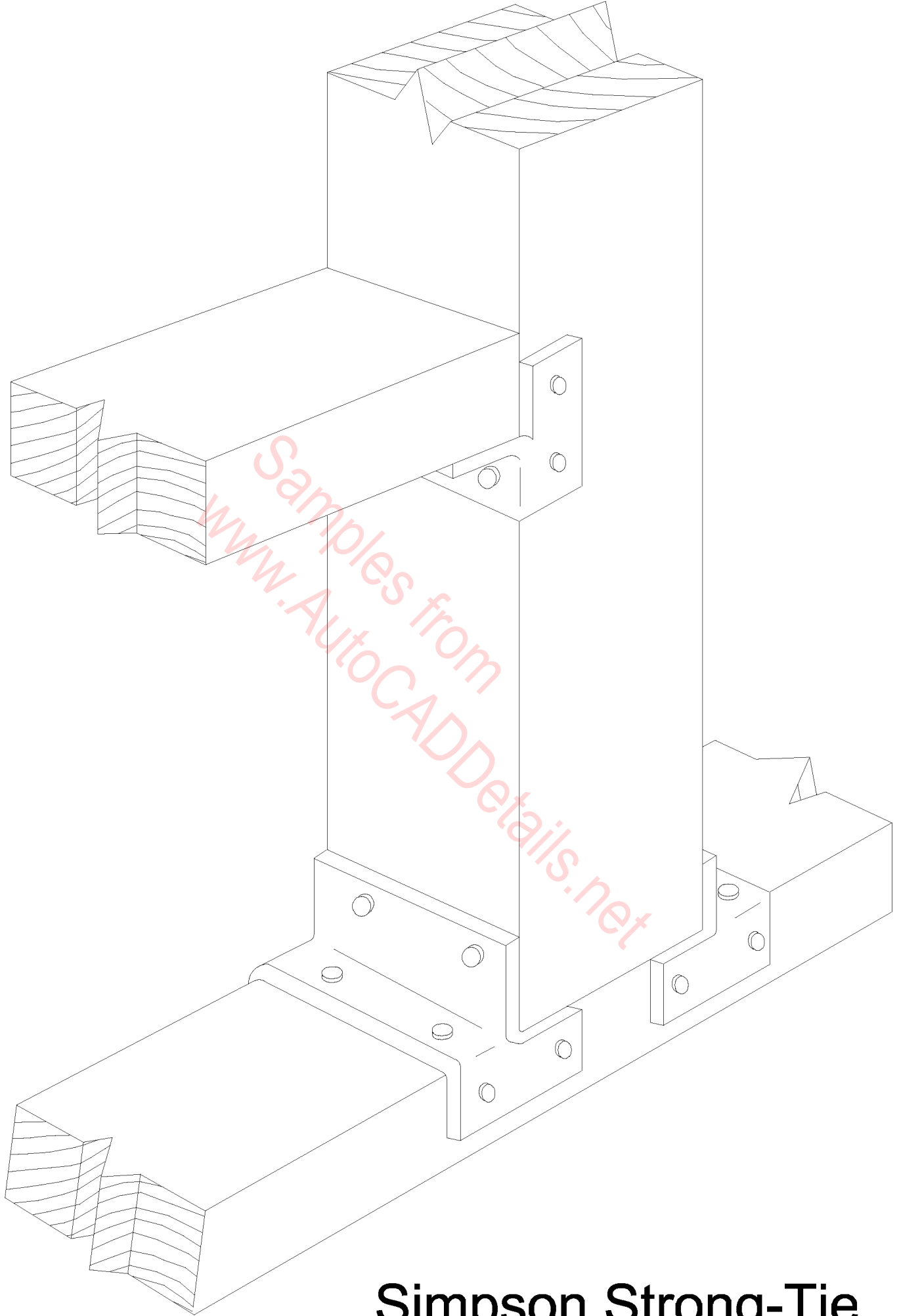

**Simpson Strong-Tie  
FC**

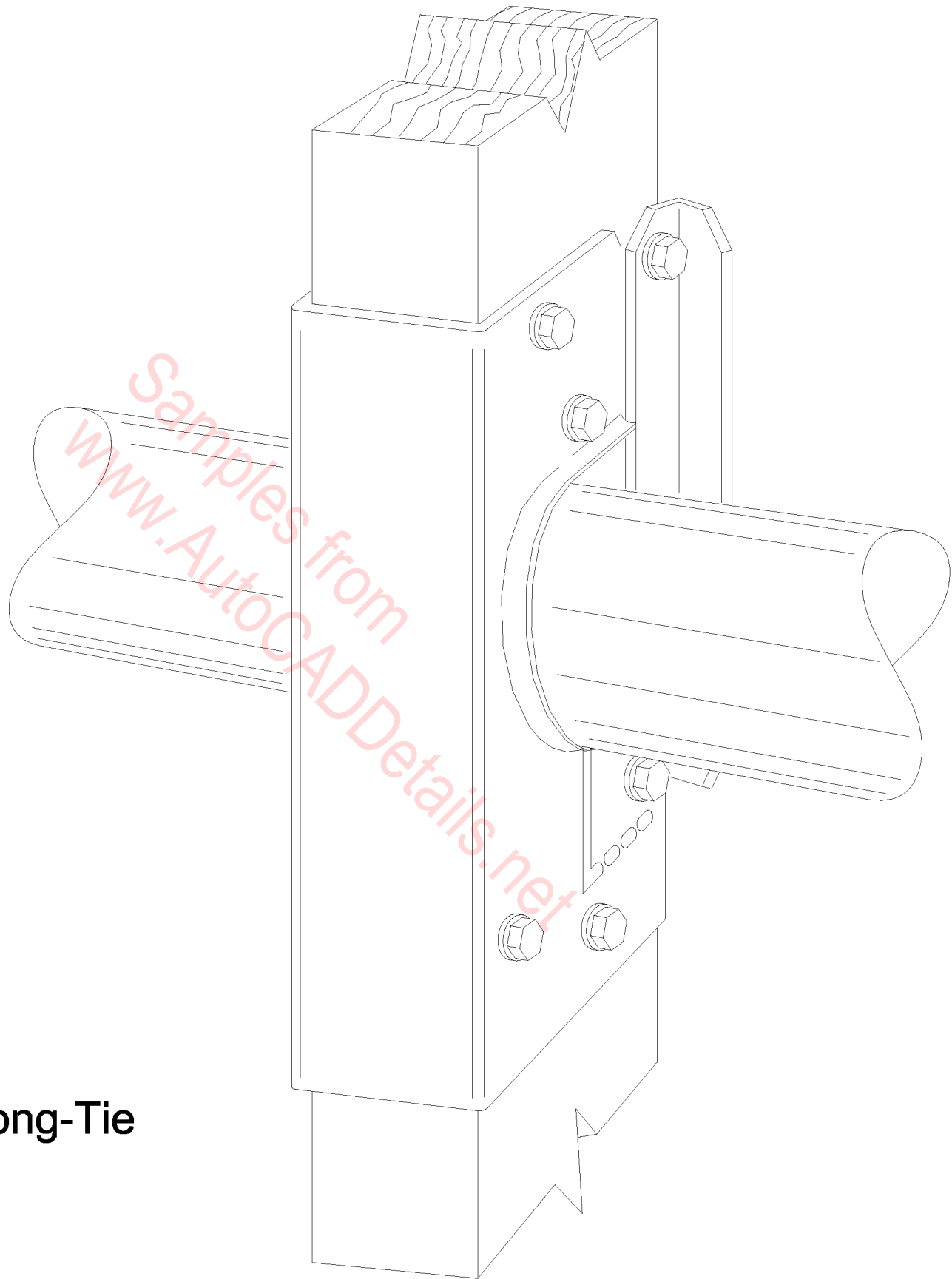

**Simpson Strong-Tie  
HSS2**

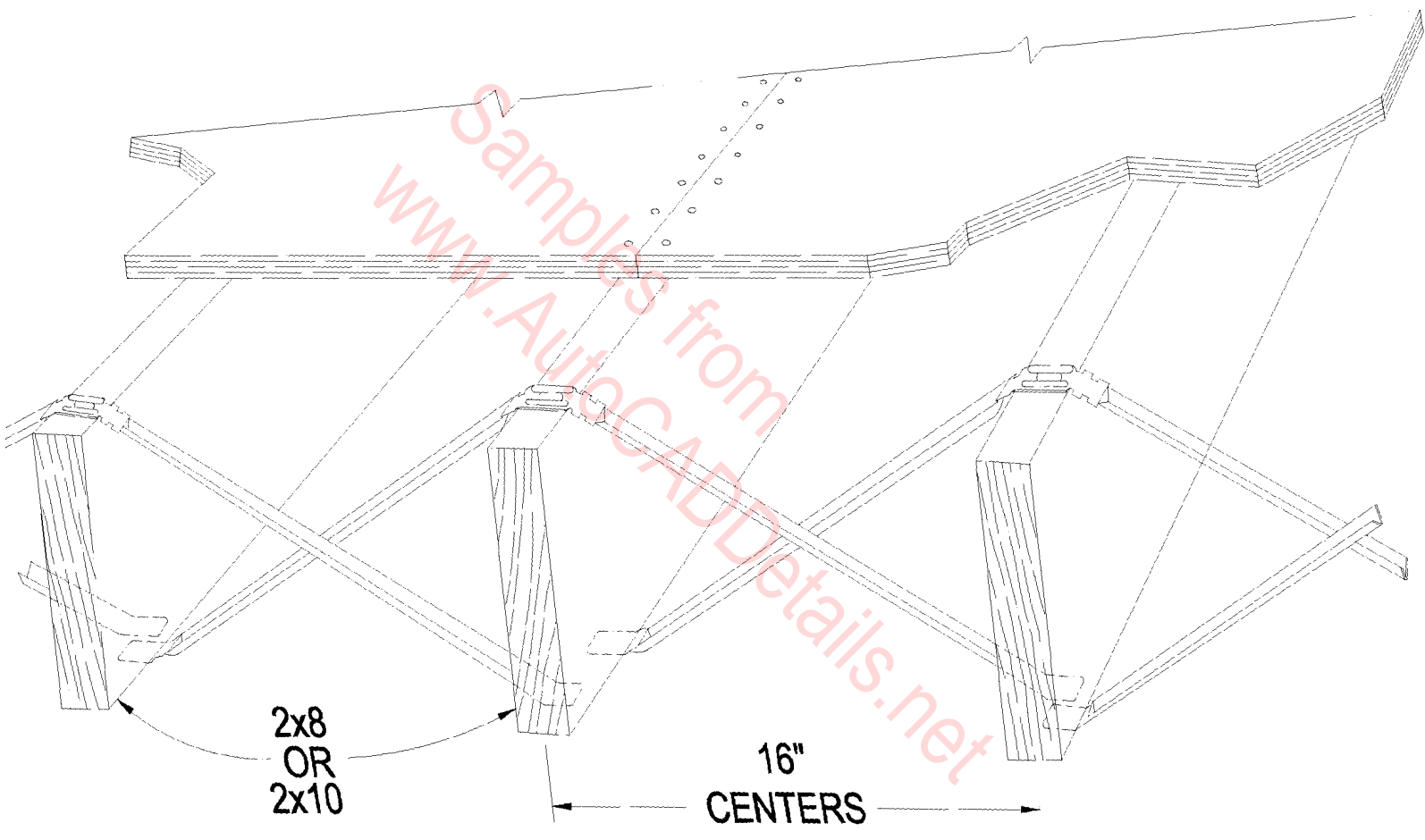

Simpson Strong-Tie  
LTB40

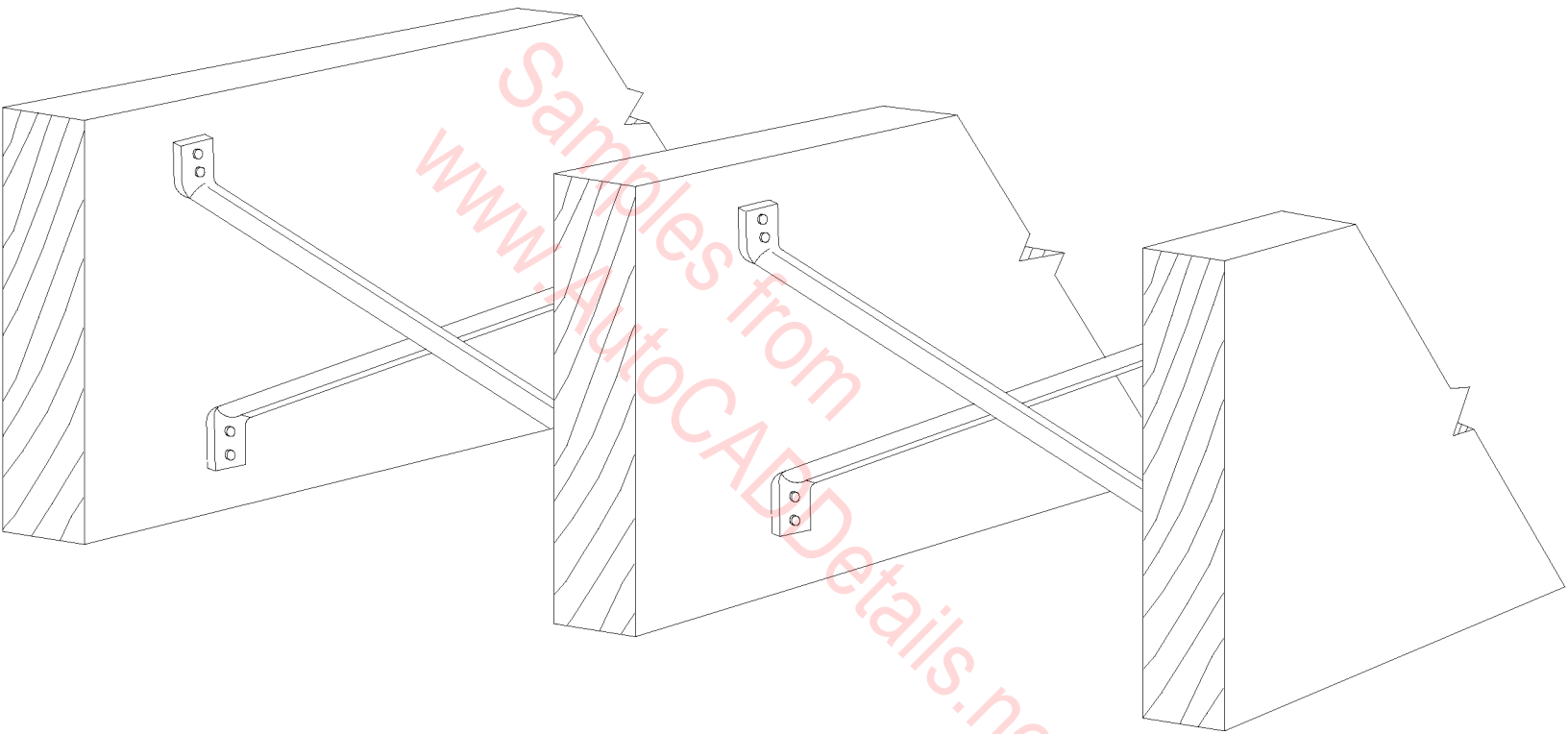

**Simpson Strong-Tie  
NB**

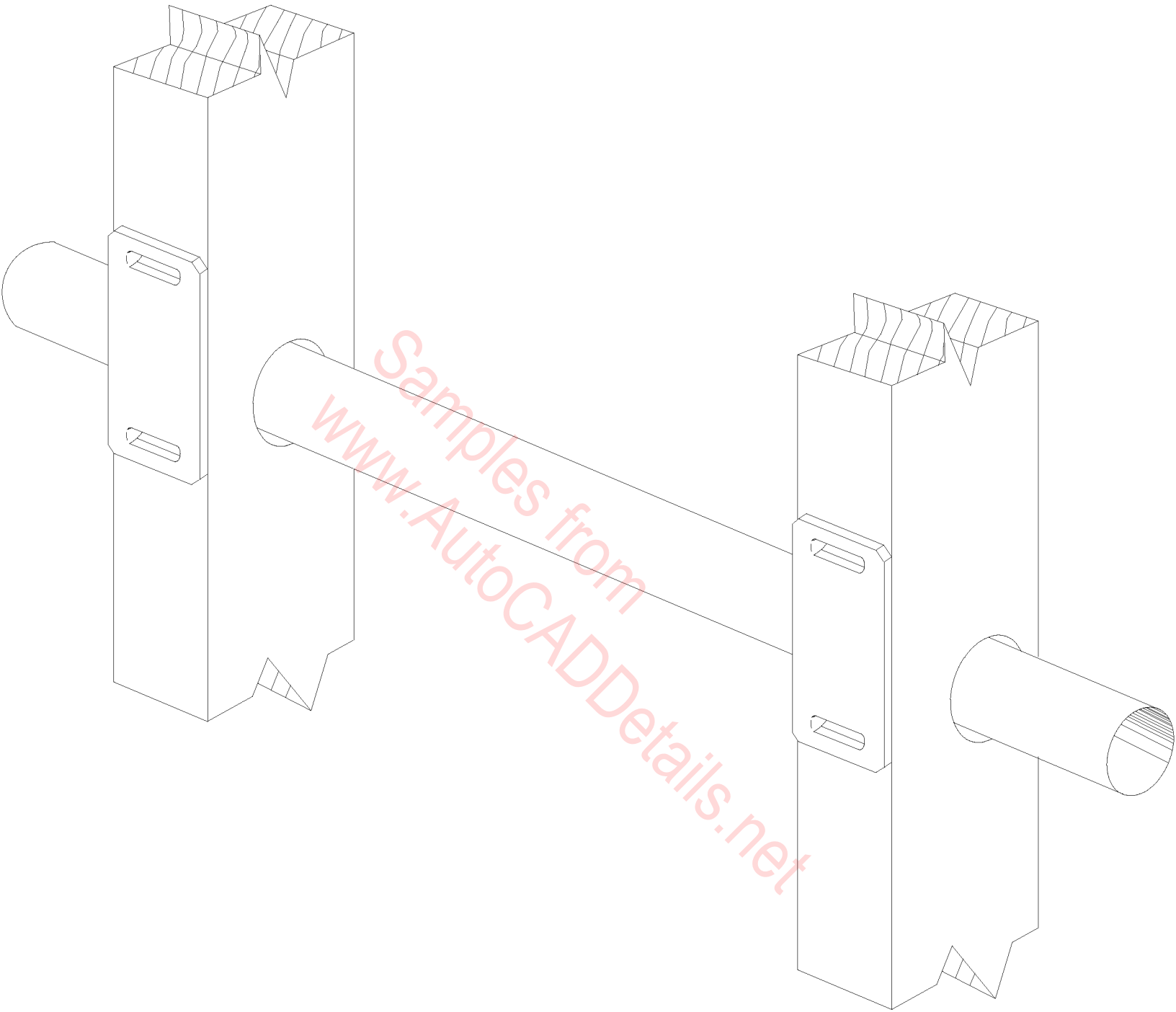

**NSP**

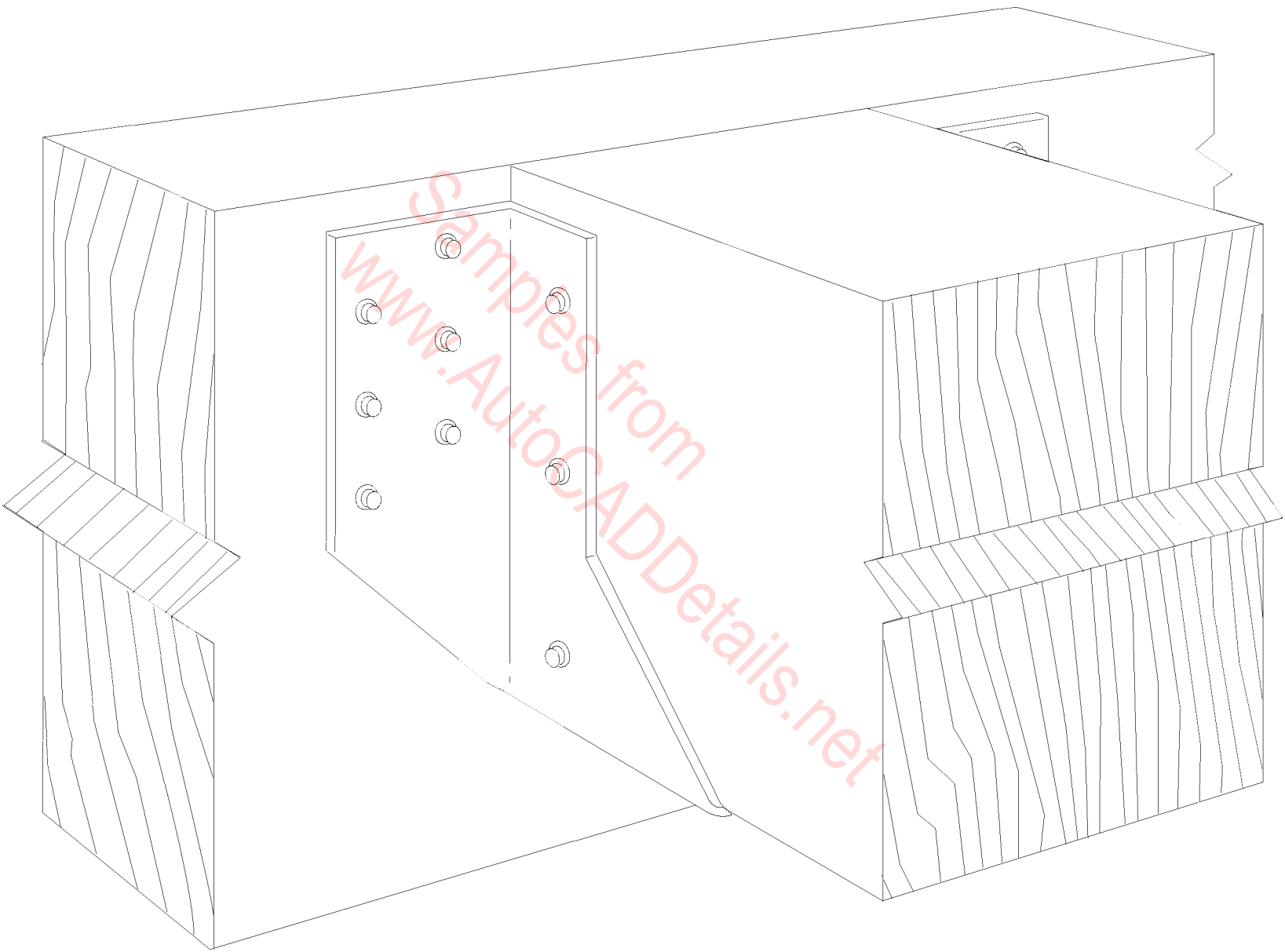

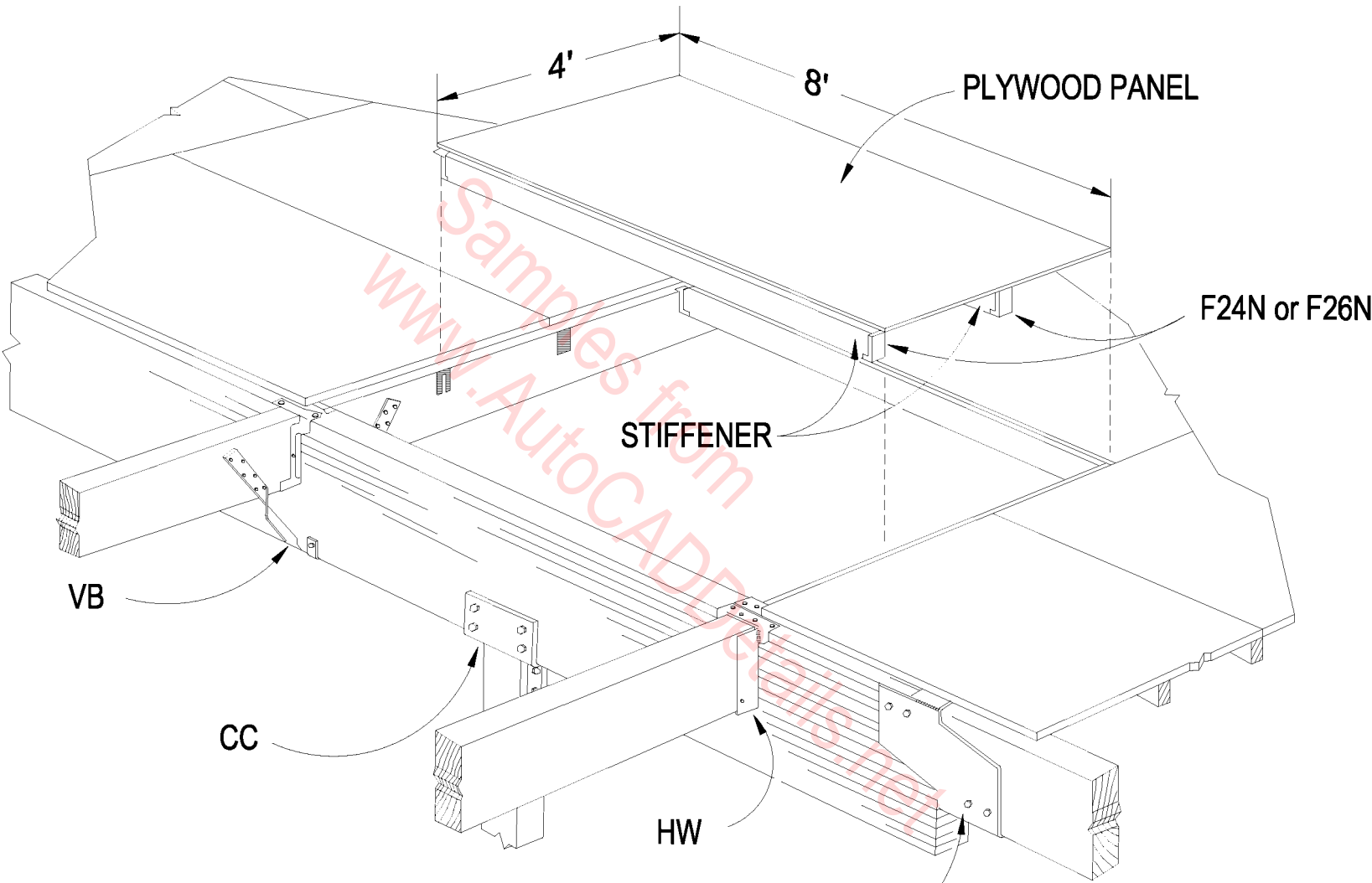

Simpson Strong-Tie  
Panelize



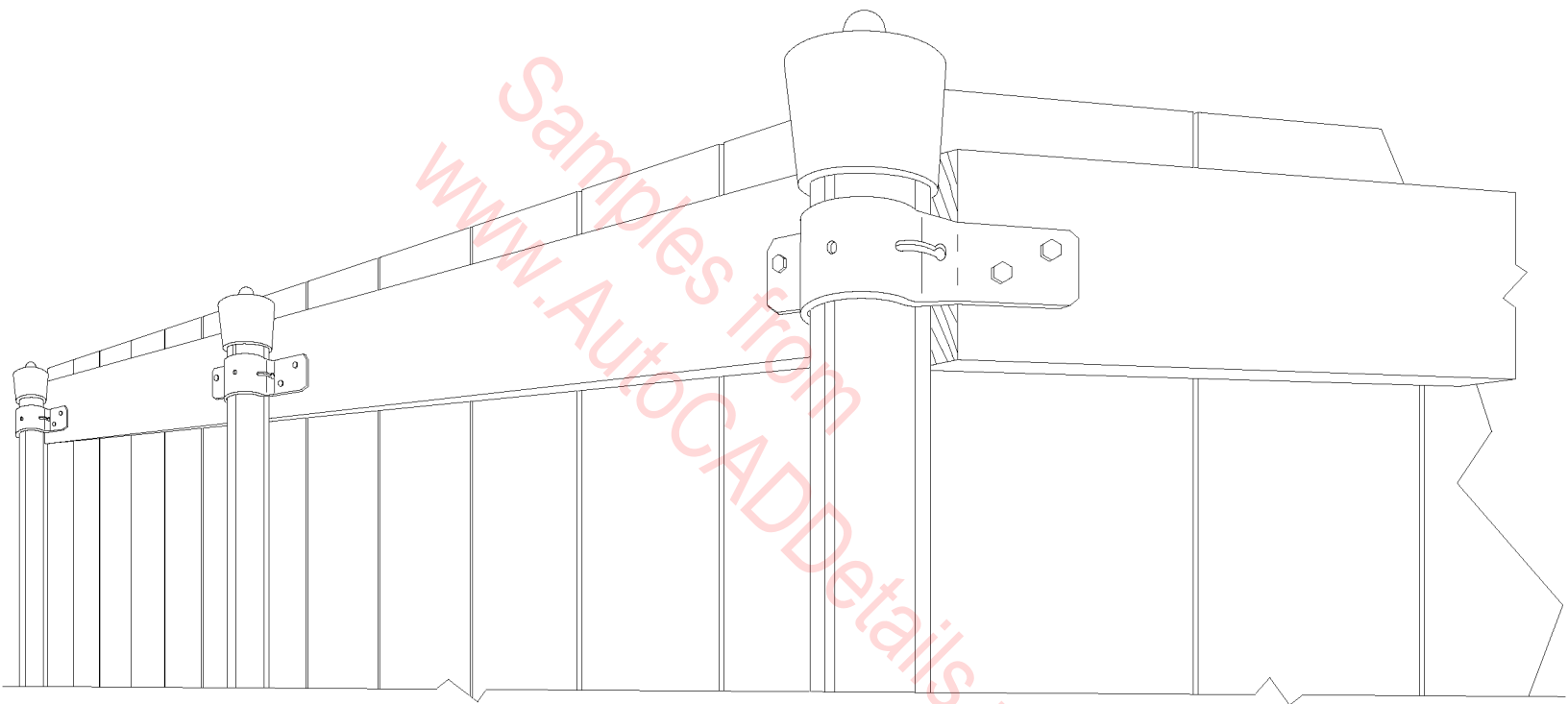

**Simpson Strong-Tie  
PGT2**

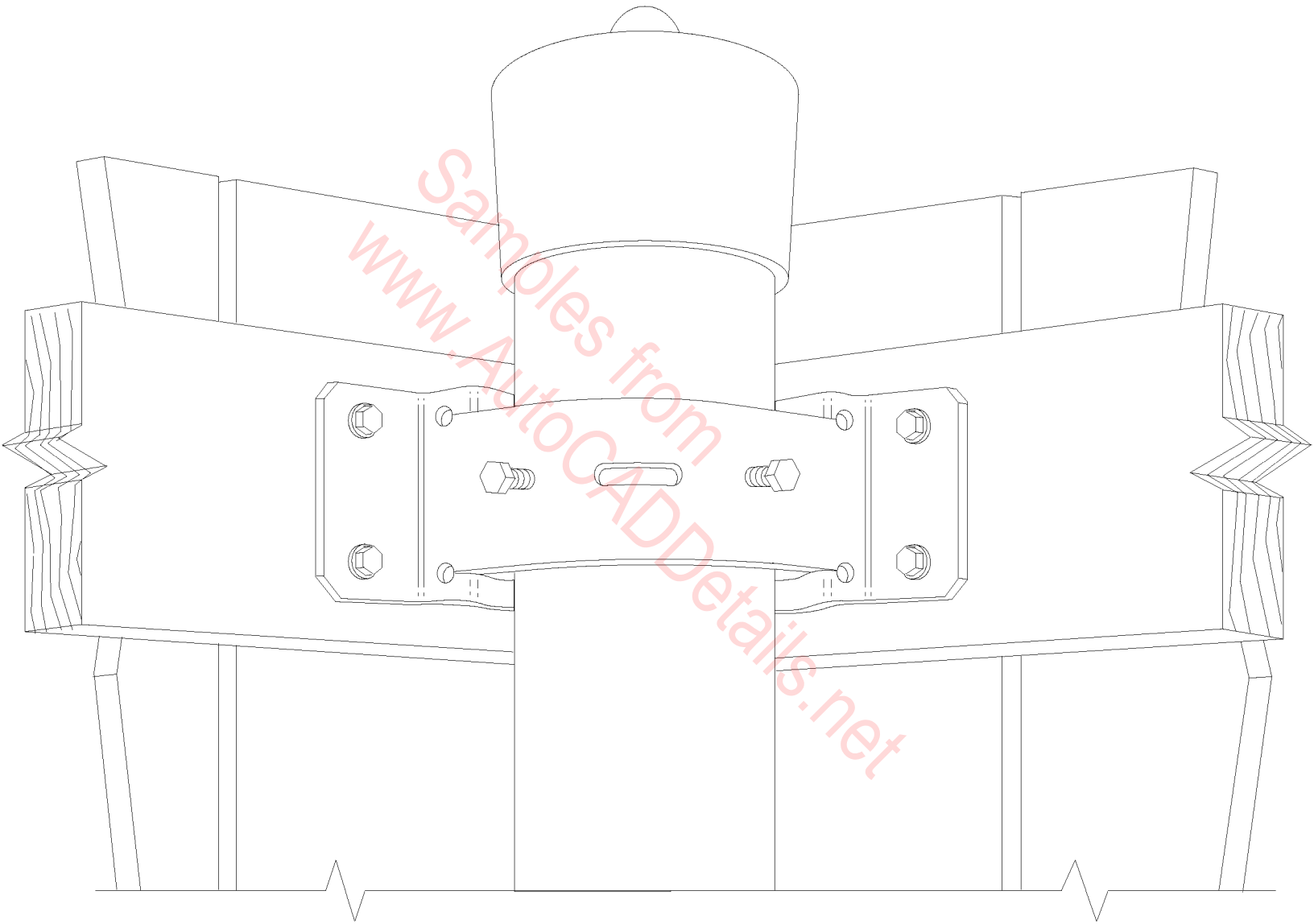

Samples from  
[www.AutocADDetails.net](http://www.AutocADDetails.net)

PROVIDES  
1/8" GAP

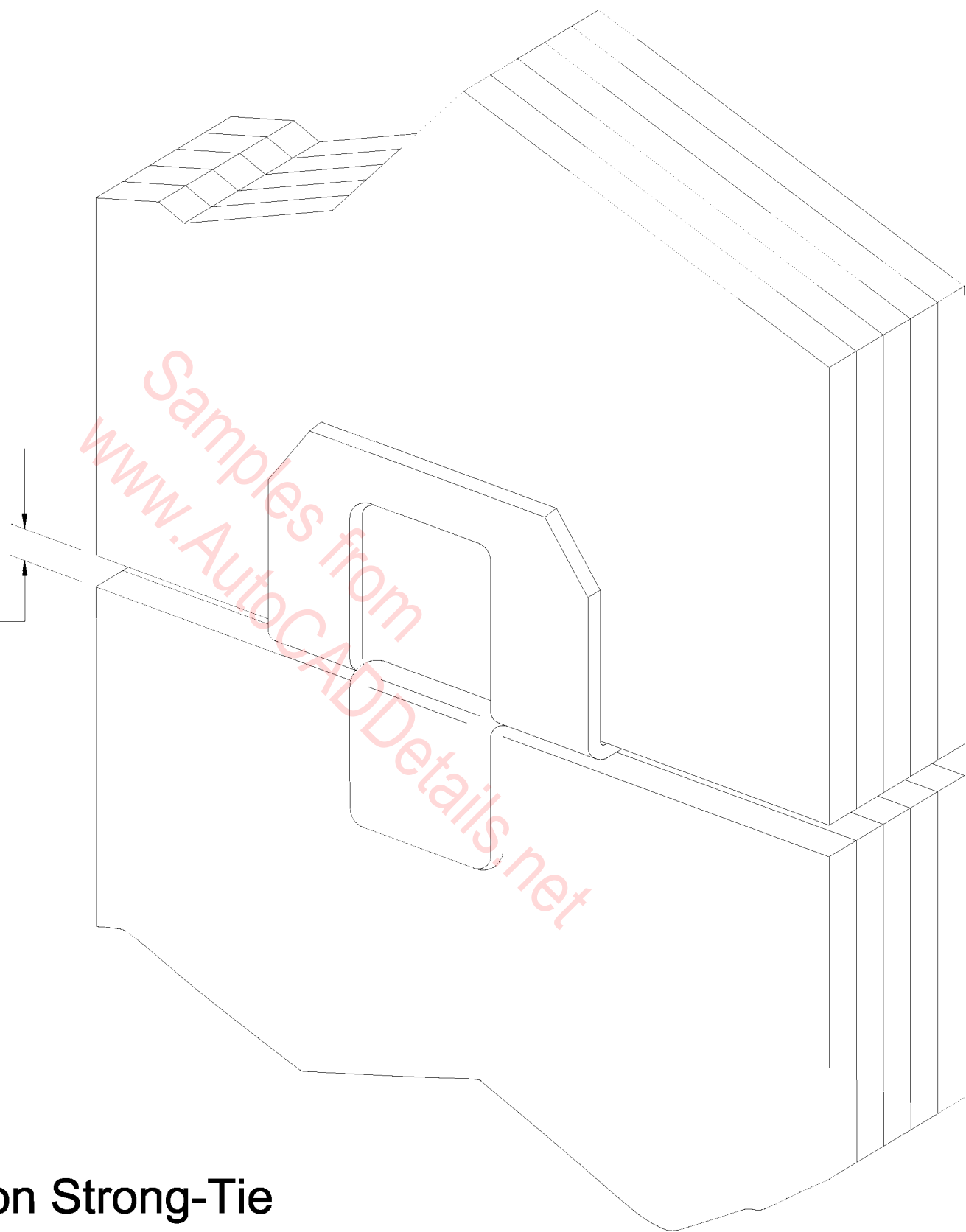

Simpson Strong-Tie  
PSCL

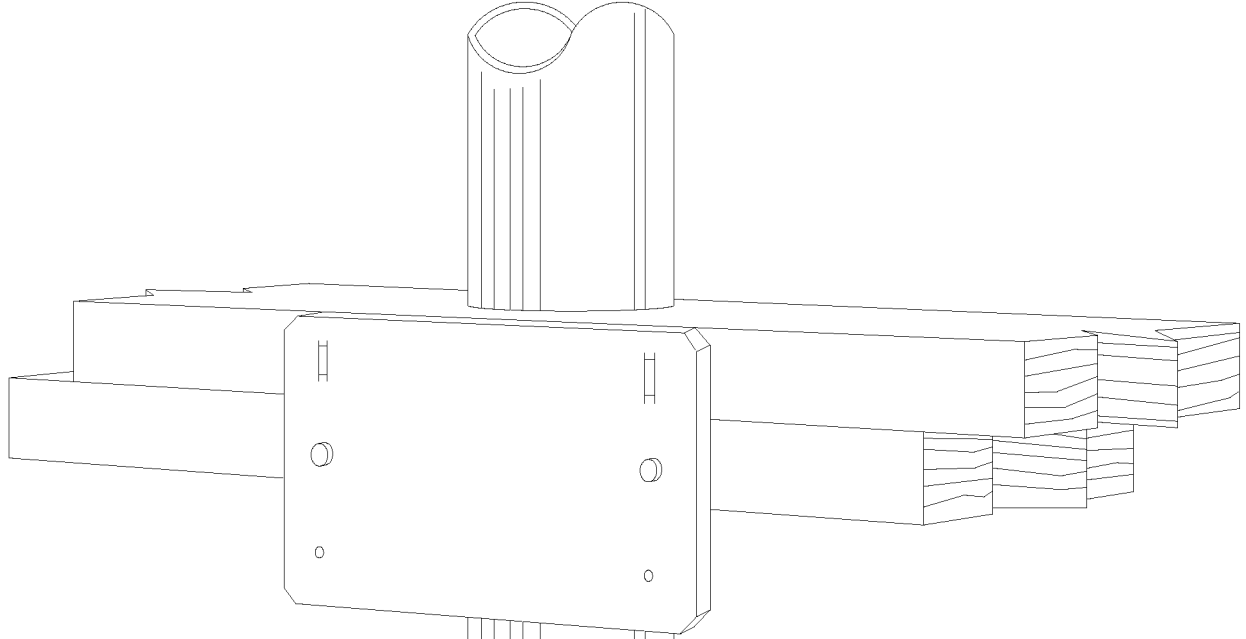

Samples from  
[www.AutoCADDetails.net](http://www.AutoCADDetails.net)

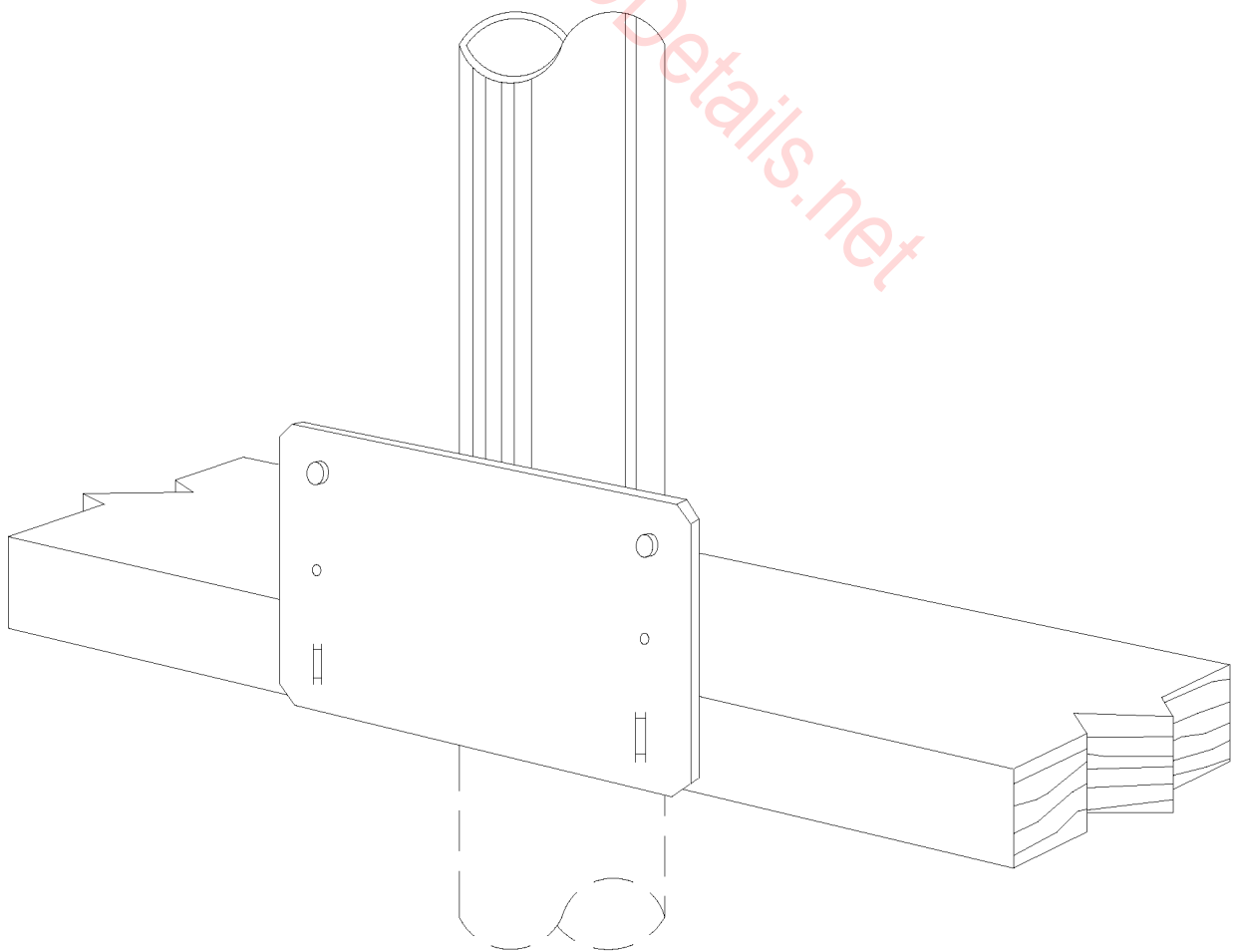

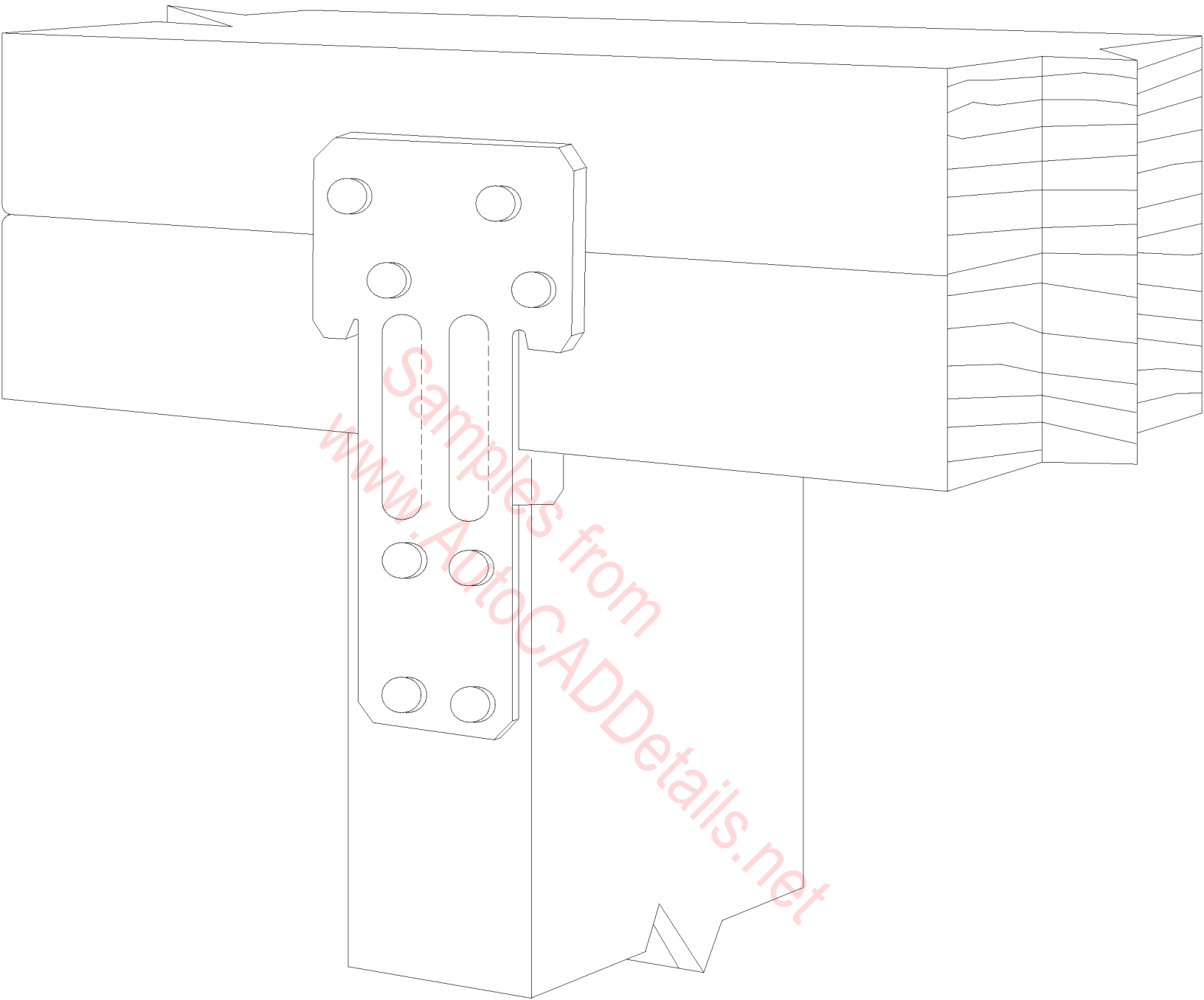

# Stud to Double Top Plates

Simpson Strong-Tie  
RSP4

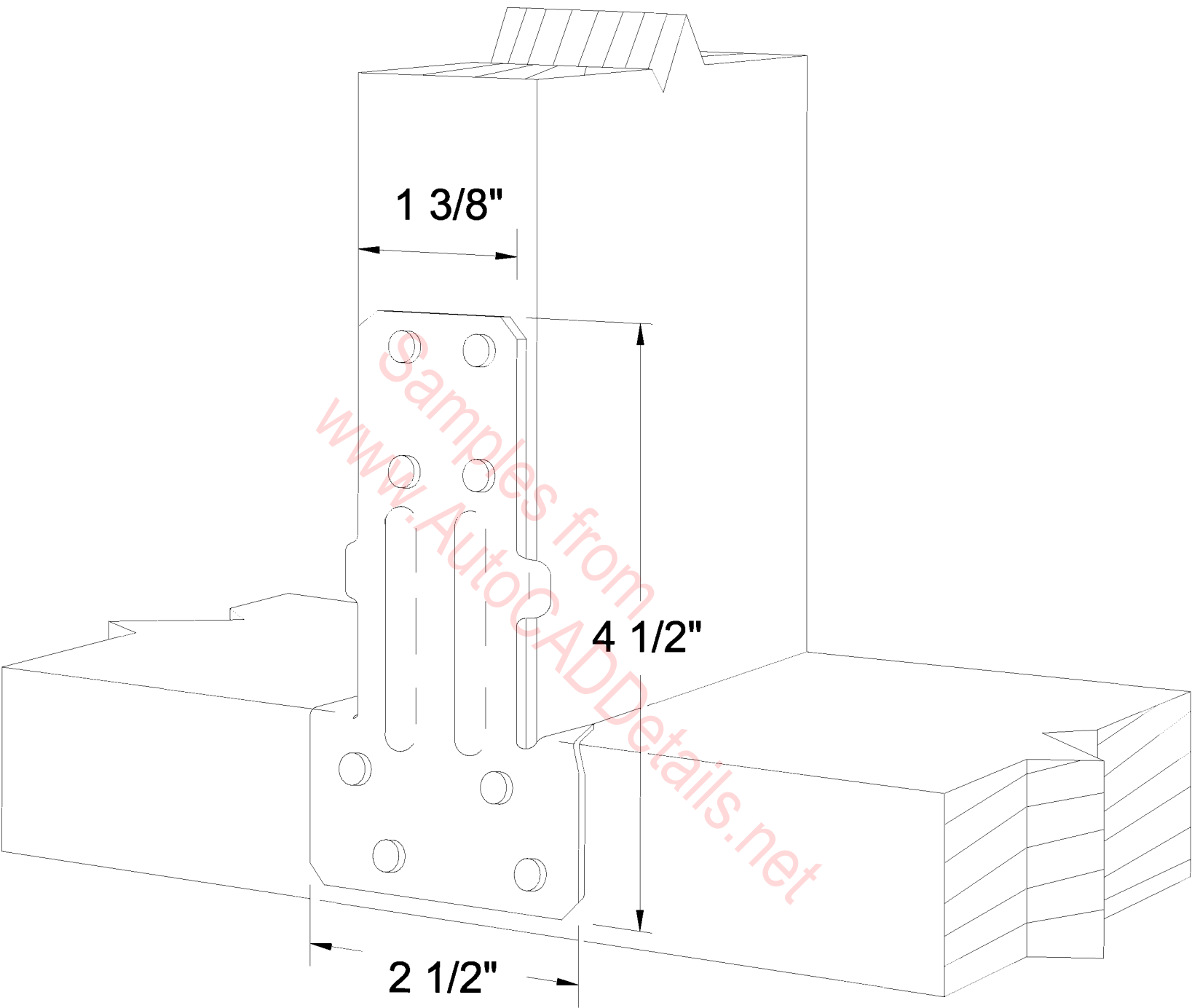

## Stud to Bottom Plate

Simpson Strong-Tie  
RSP4

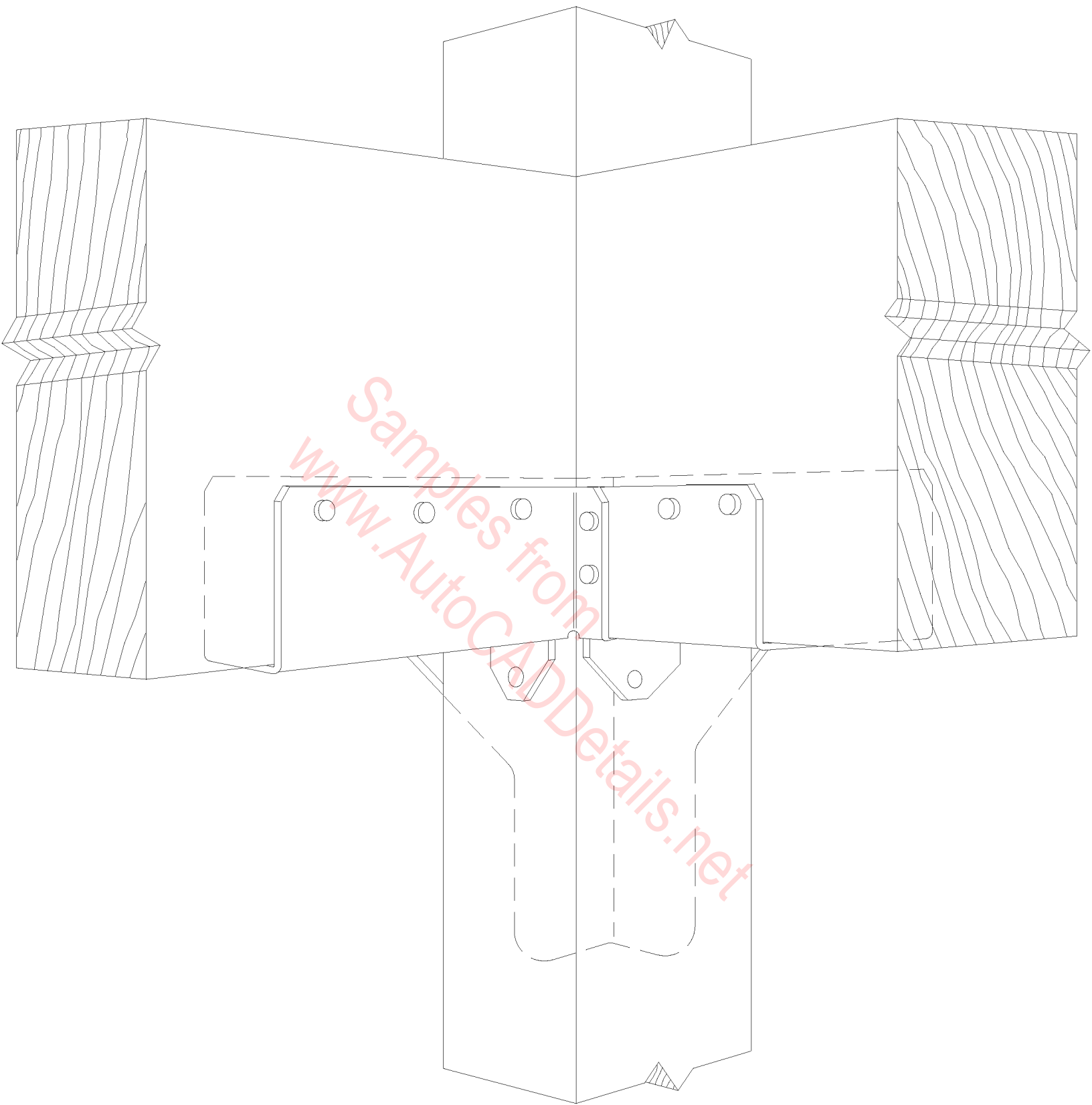

**Simpson Strong-Tie  
RTC44**



Samples from  
[www.AutoCADDetails.net](http://www.AutoCADDetails.net)

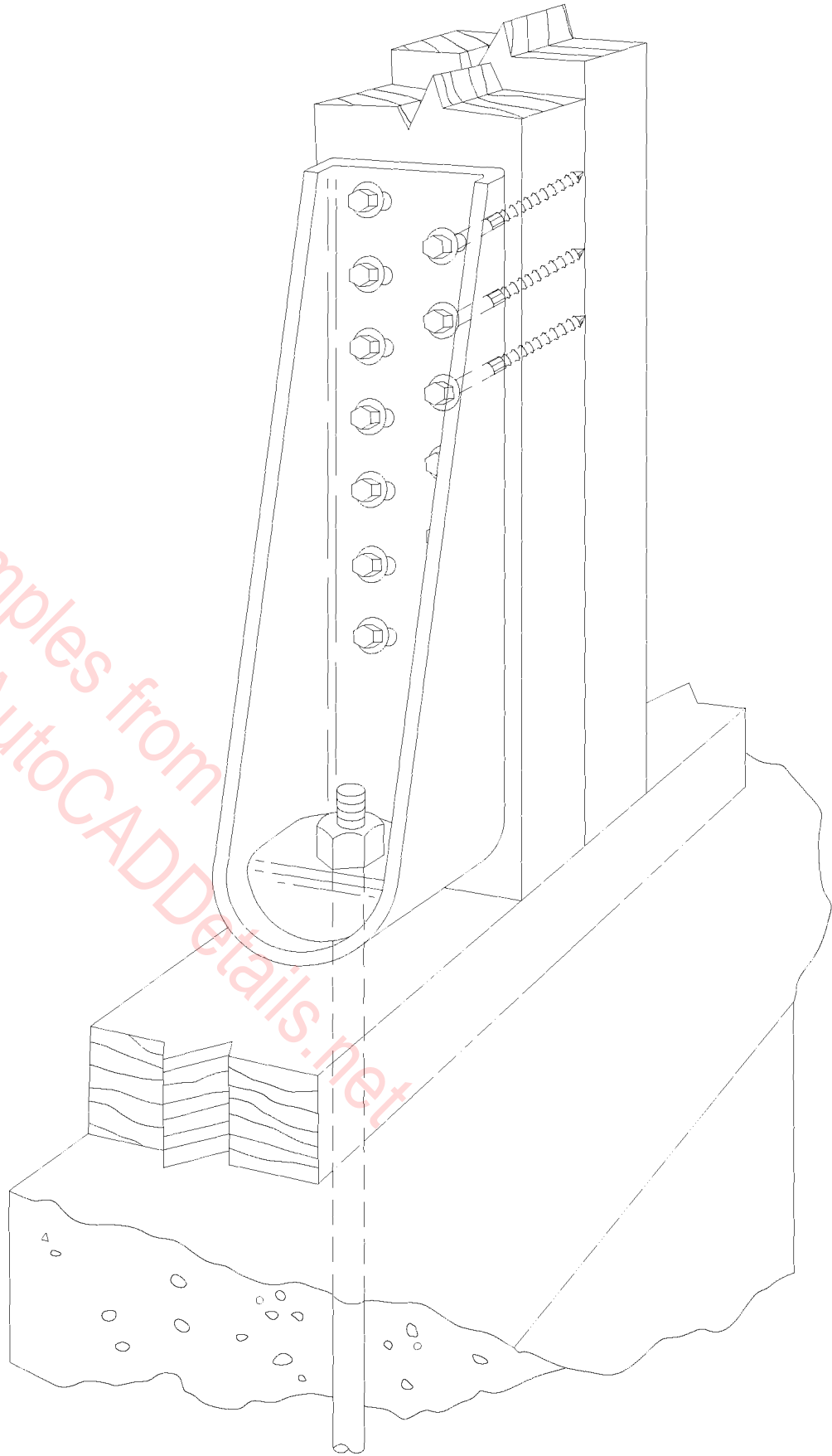

**Simpson Strong-Tie  
SDS**



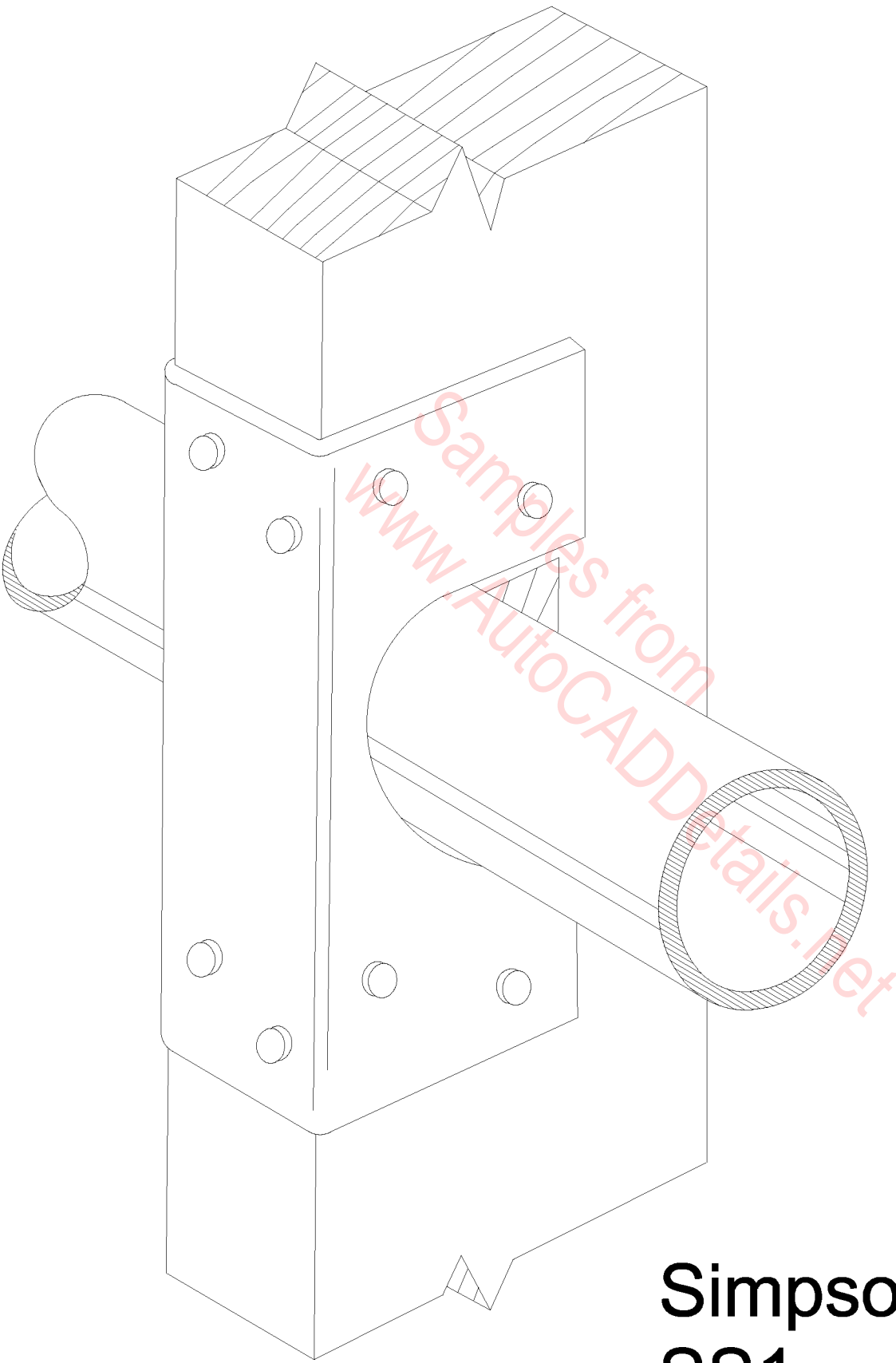

**Simpson Strong-Tie  
SS1**

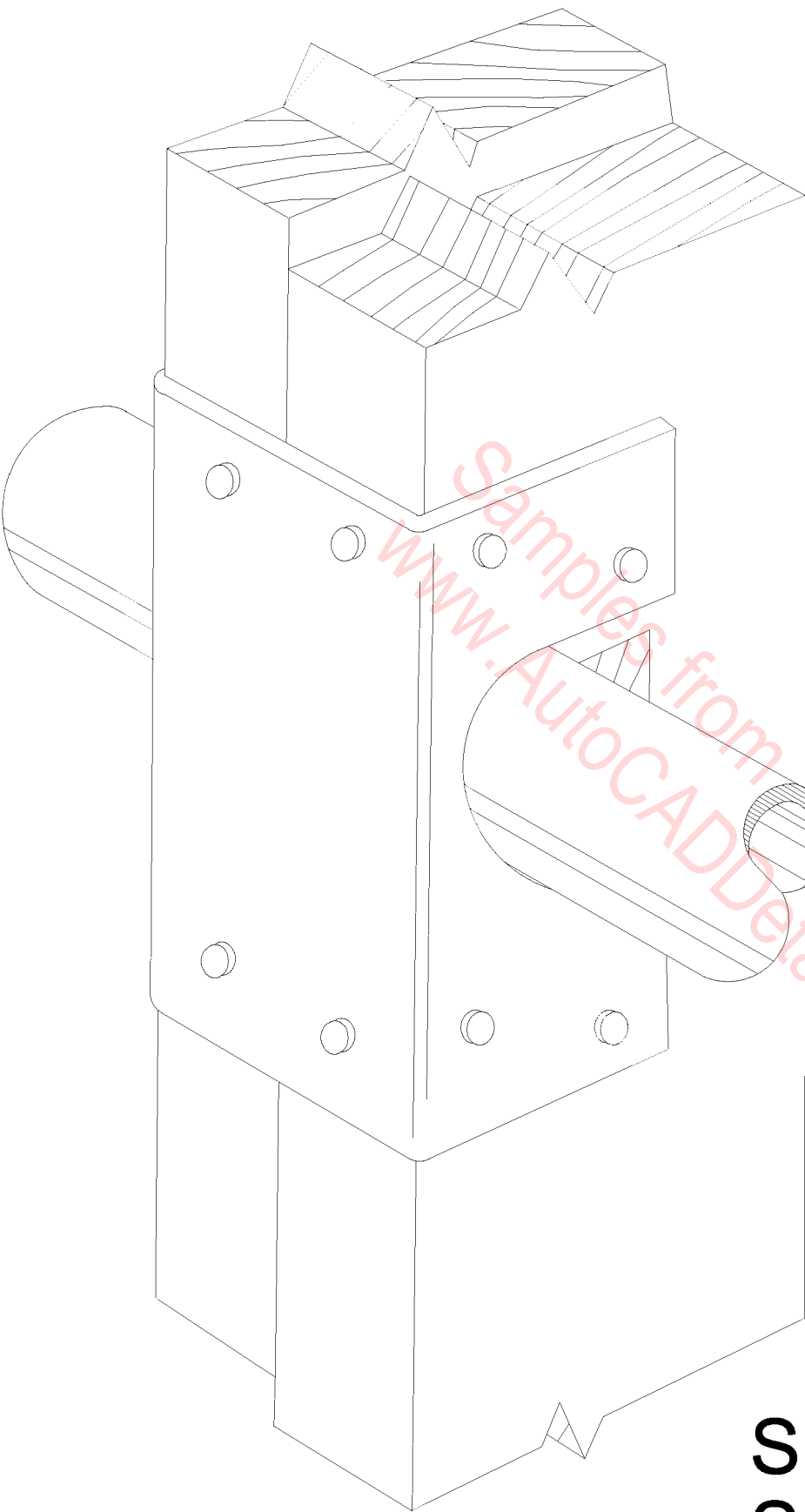

Samples from  
[www.AutoCADDetails.net](http://www.AutoCADDetails.net)

**Simpson Strong-Tie  
SS3**

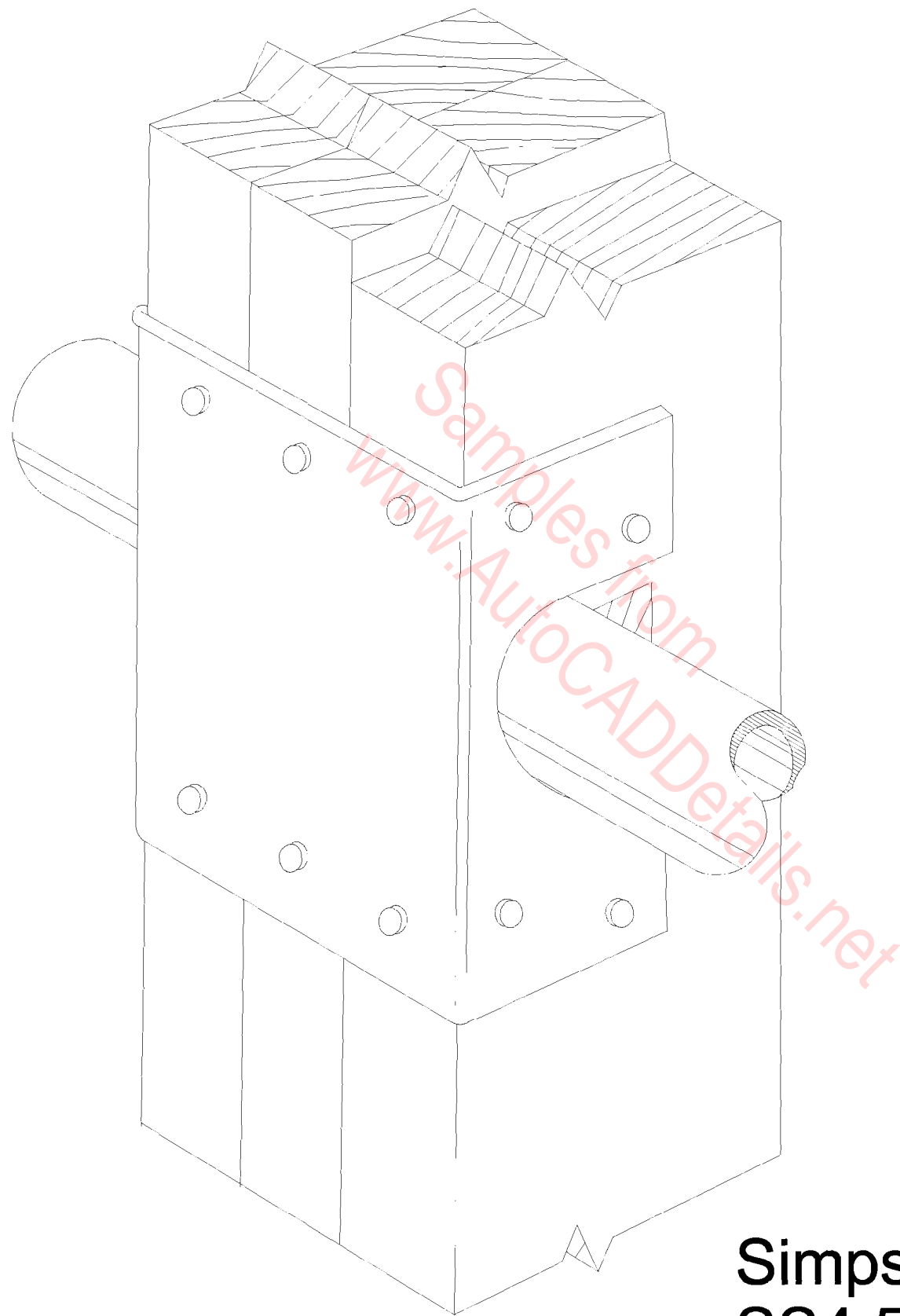

**Simpson Strong-Tie  
SS4.5**

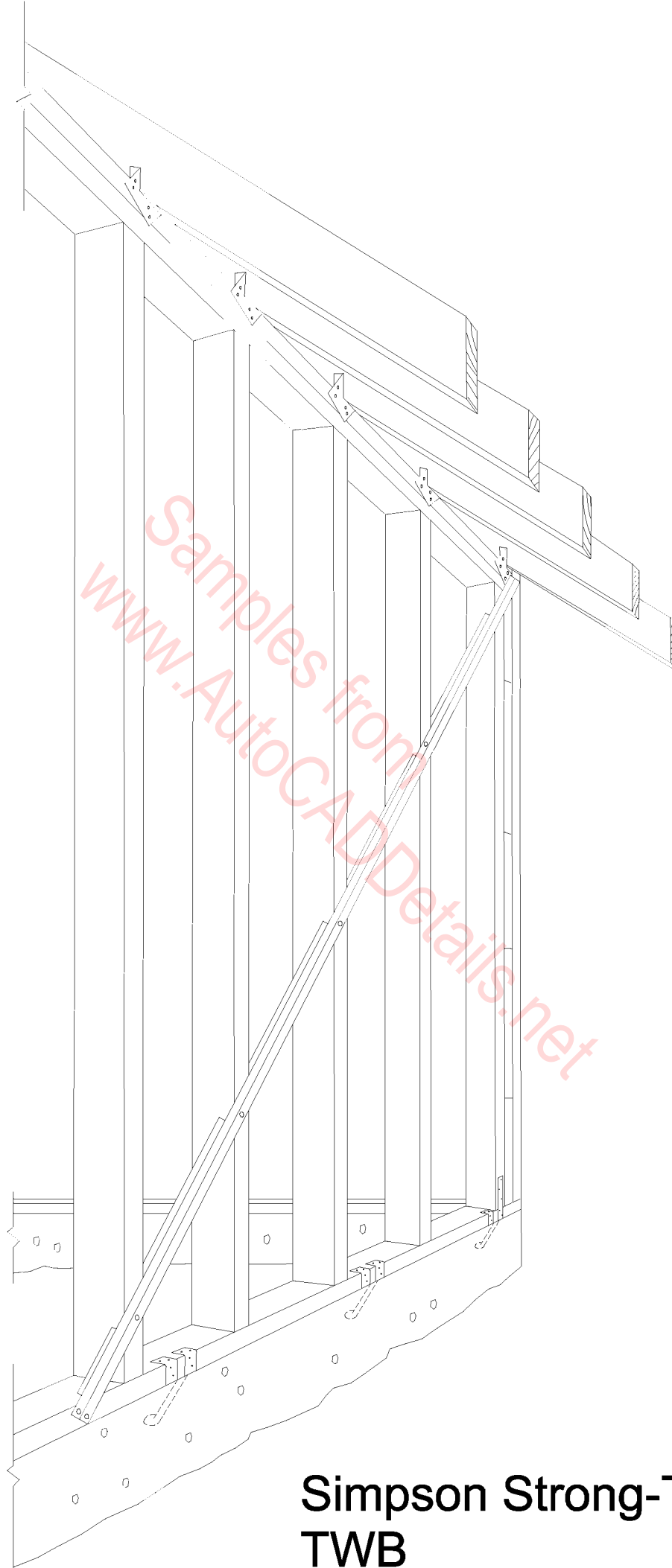

Samples from  
[www.AutoCADDetails.net](http://www.AutoCADDetails.net)

**Simpson Strong-Tie  
TWB**

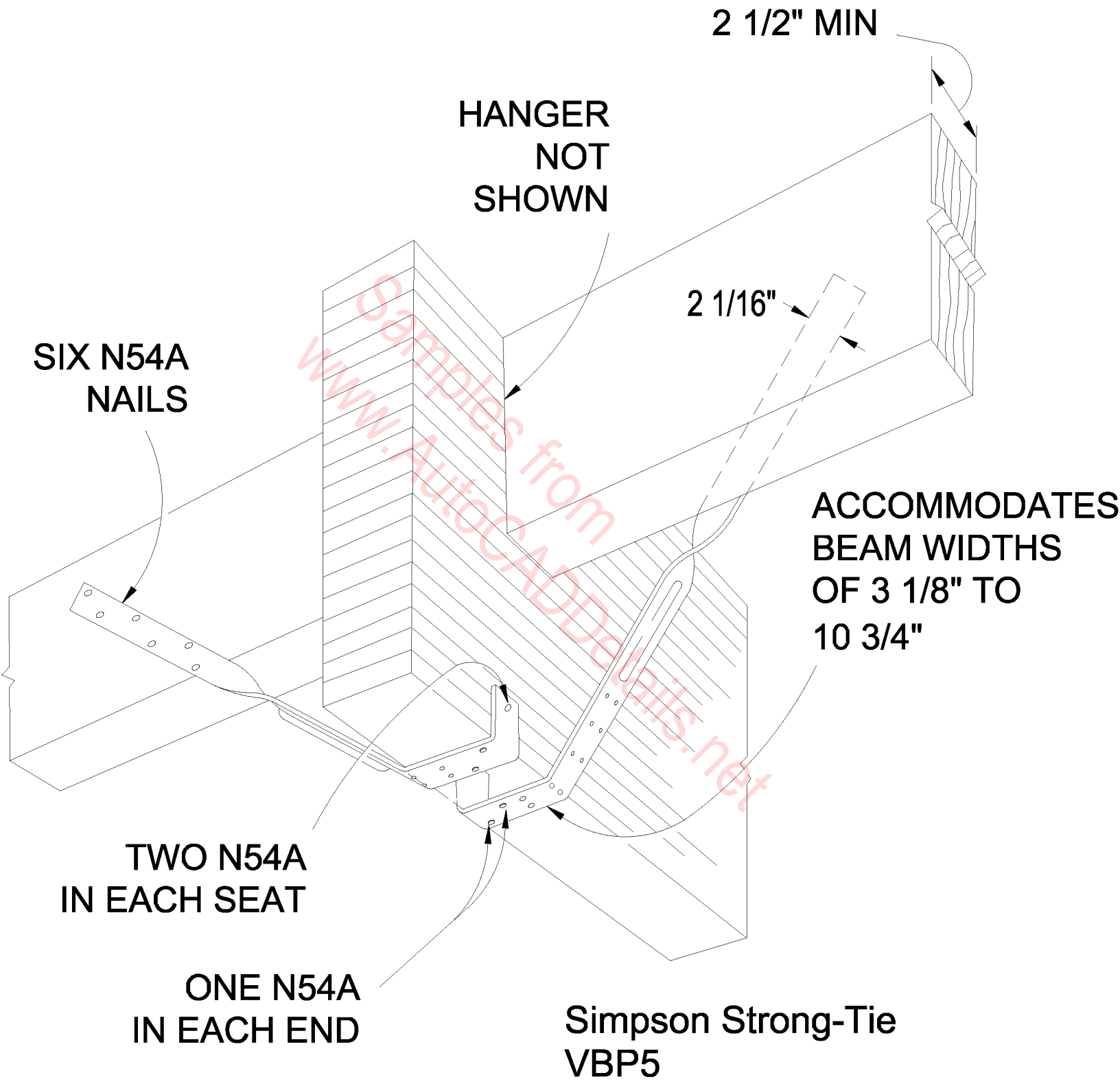

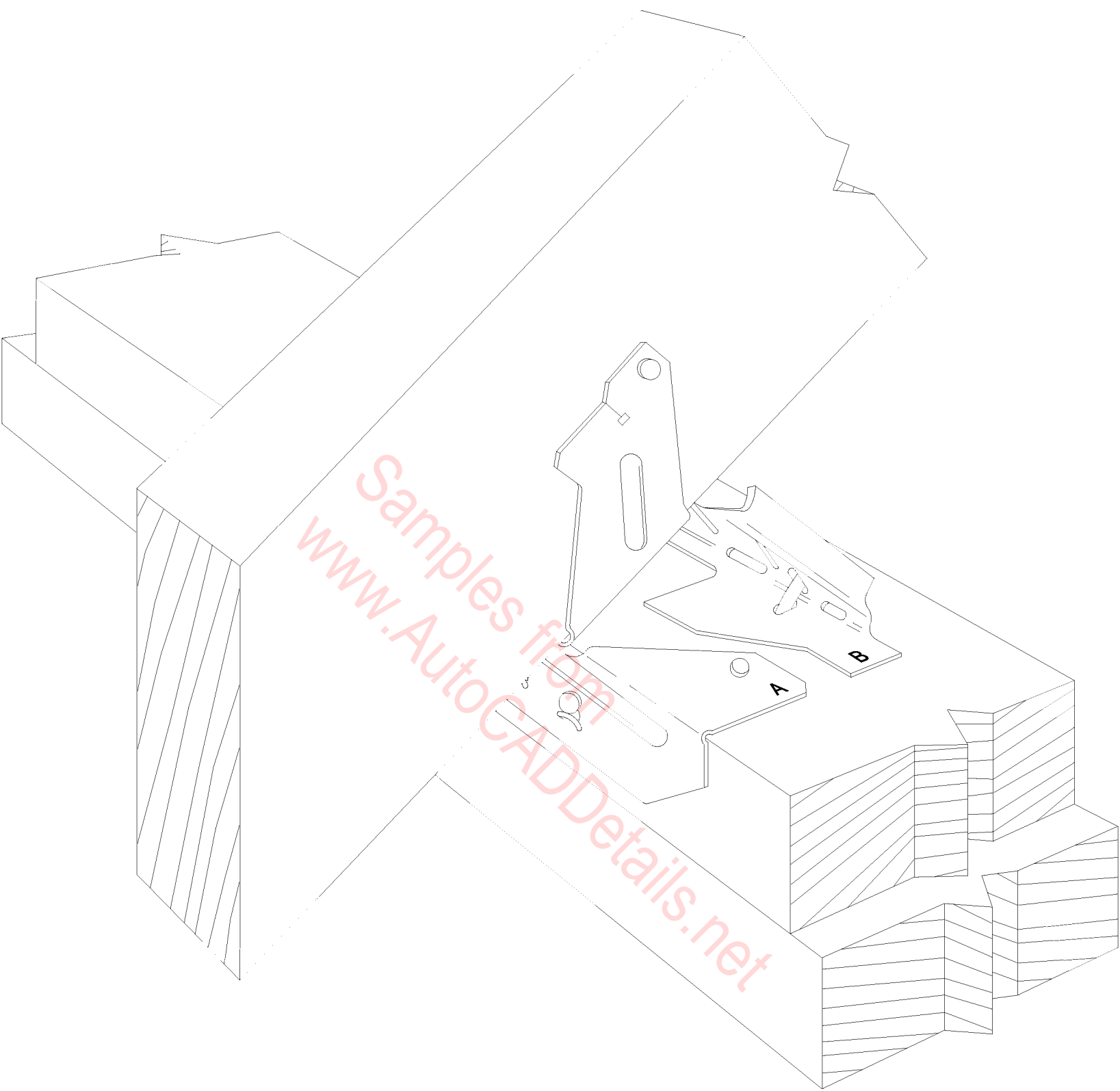

# VARIABLE PITCH CONNECTOR INSTALLATION TO DOUBLE TOP PLATE

Simpson Strong-Tie  
VPA2

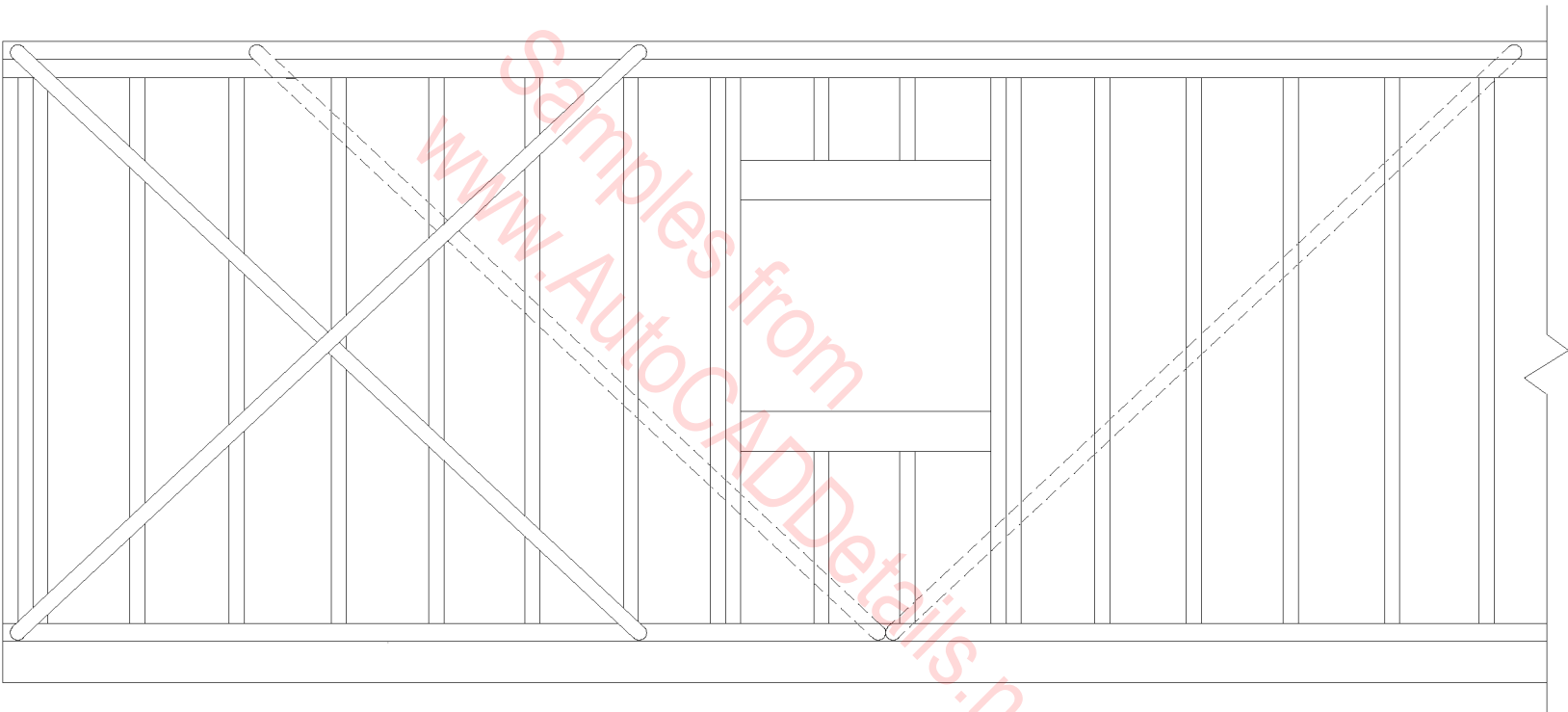

**Simpson Strong-Tie  
WB**

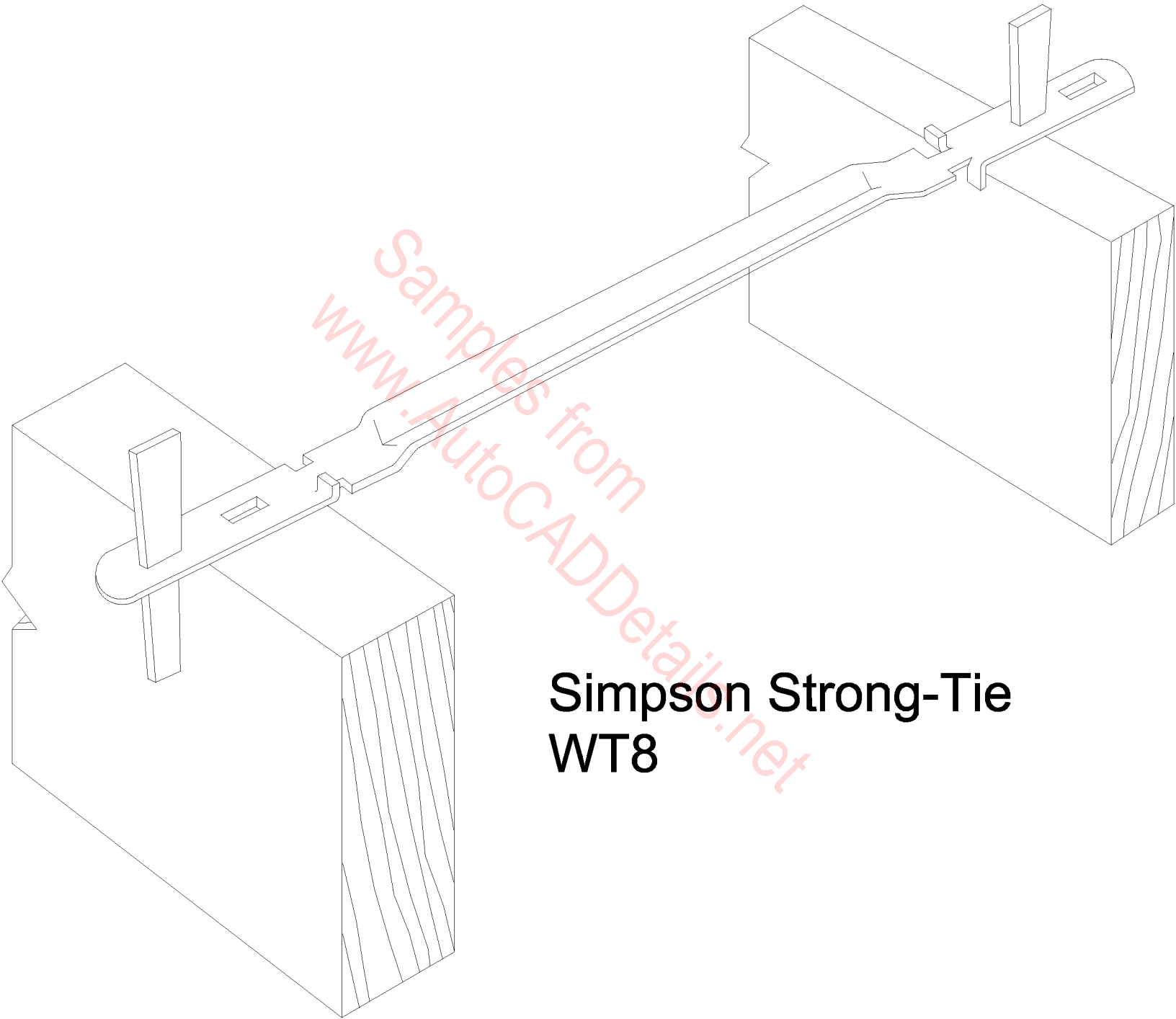

**Simpson Strong-Tie  
WT8**



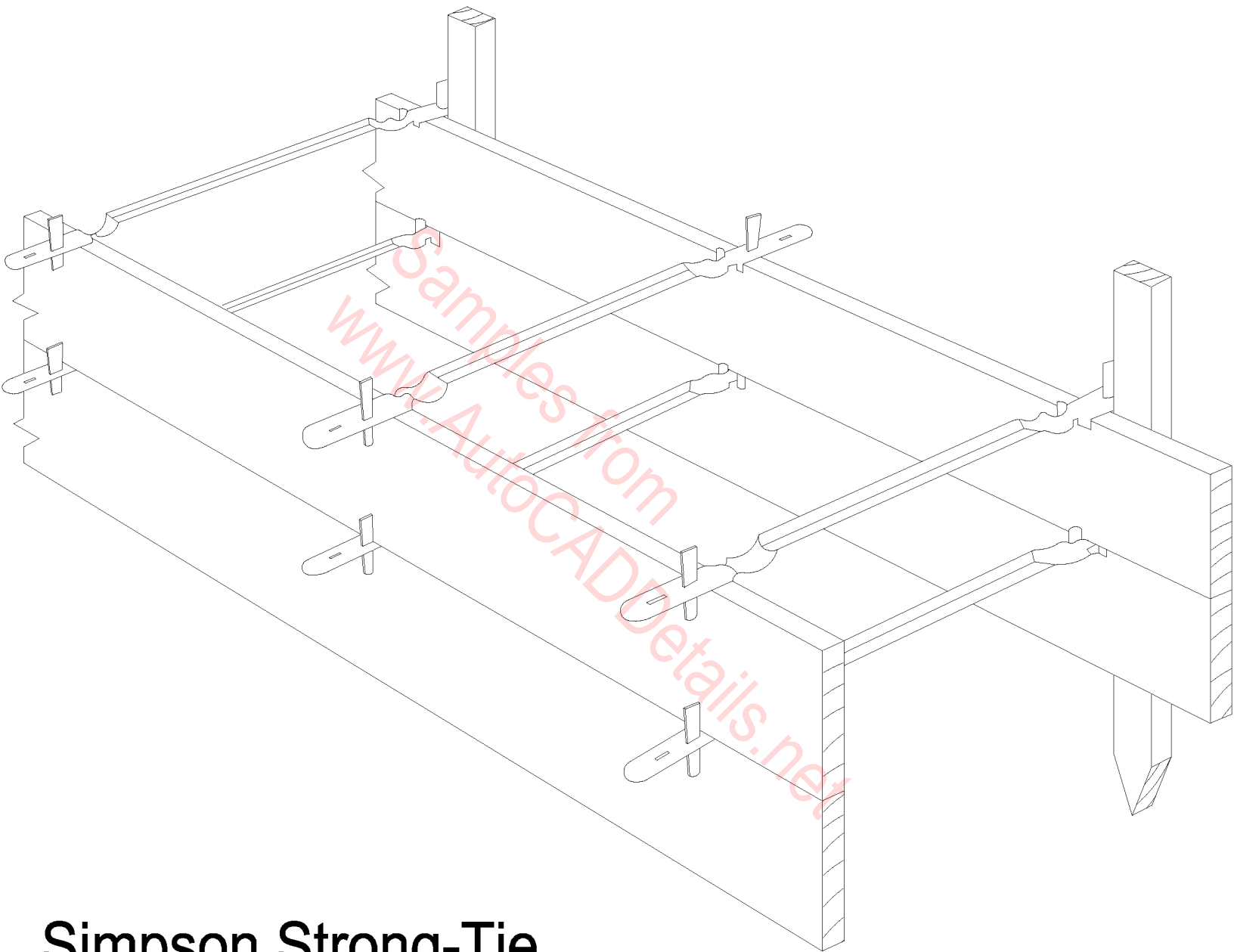

**Simpson Strong-Tie  
WT8**

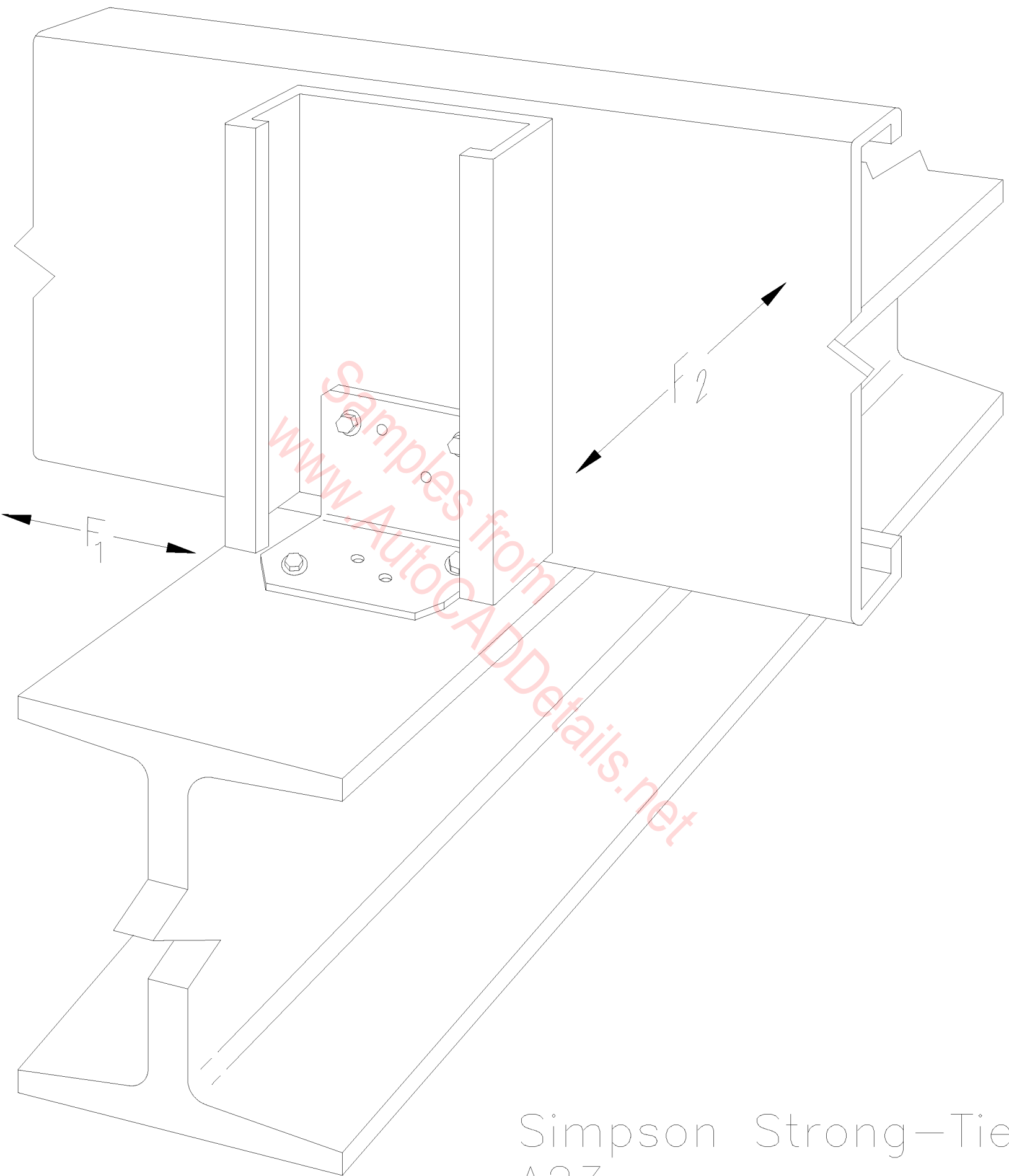

Simpson Strong-Tie  
A23

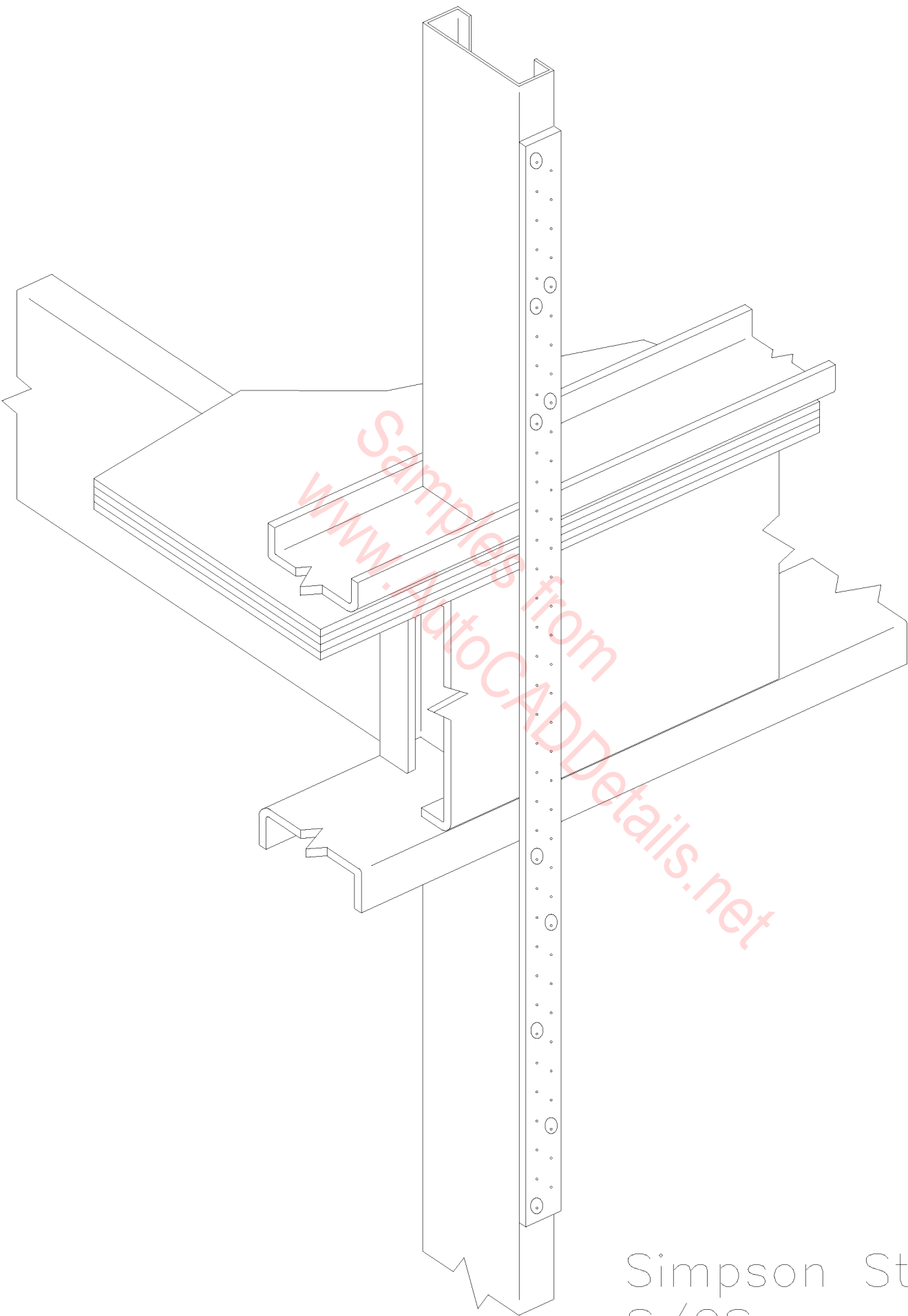

Samples from  
[www.AutocADDetails.net](http://www.AutocADDetails.net)

Simpson Strong-Tie  
S/CS

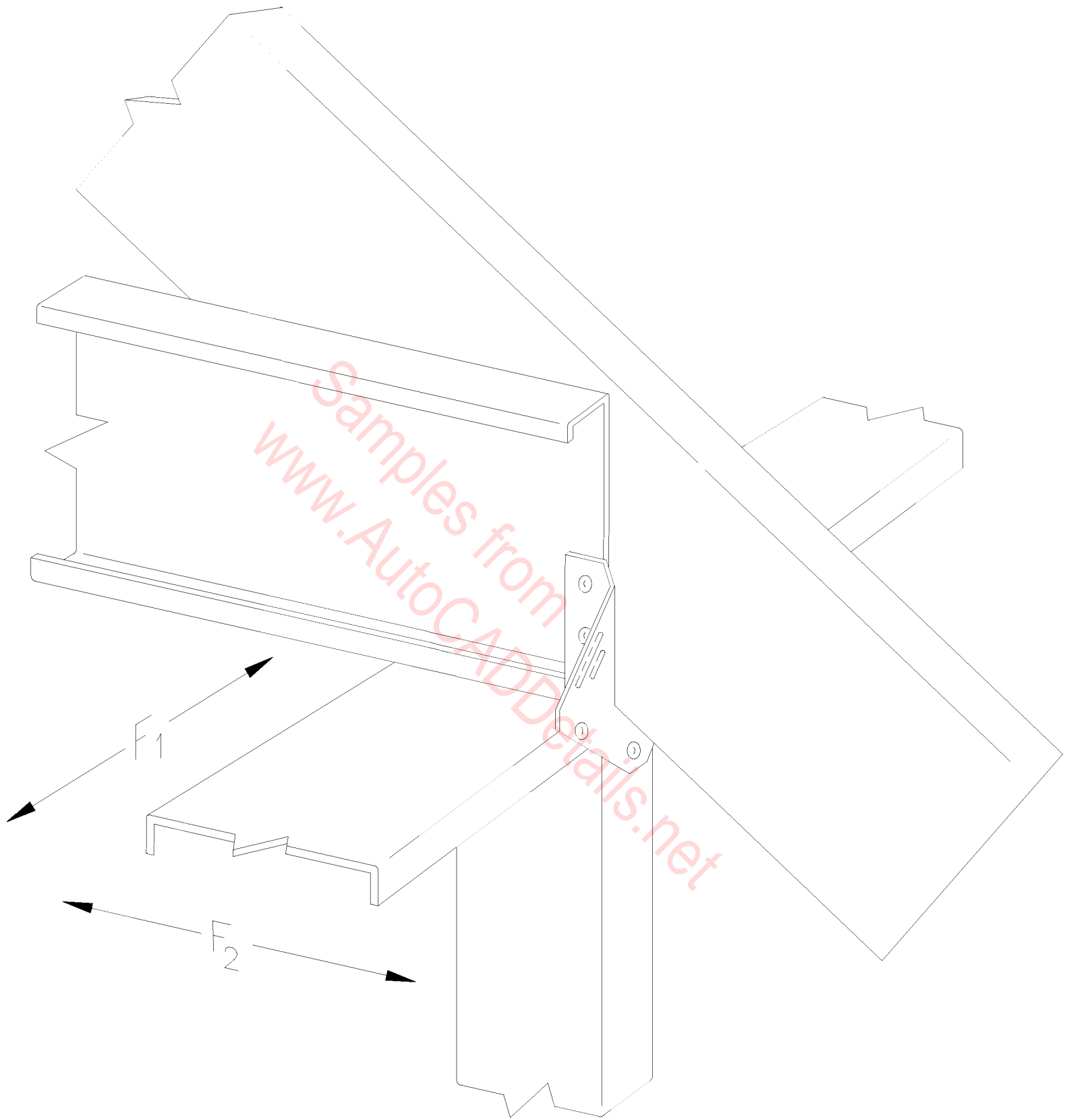

Simpson Strong-Tie  
S/H1

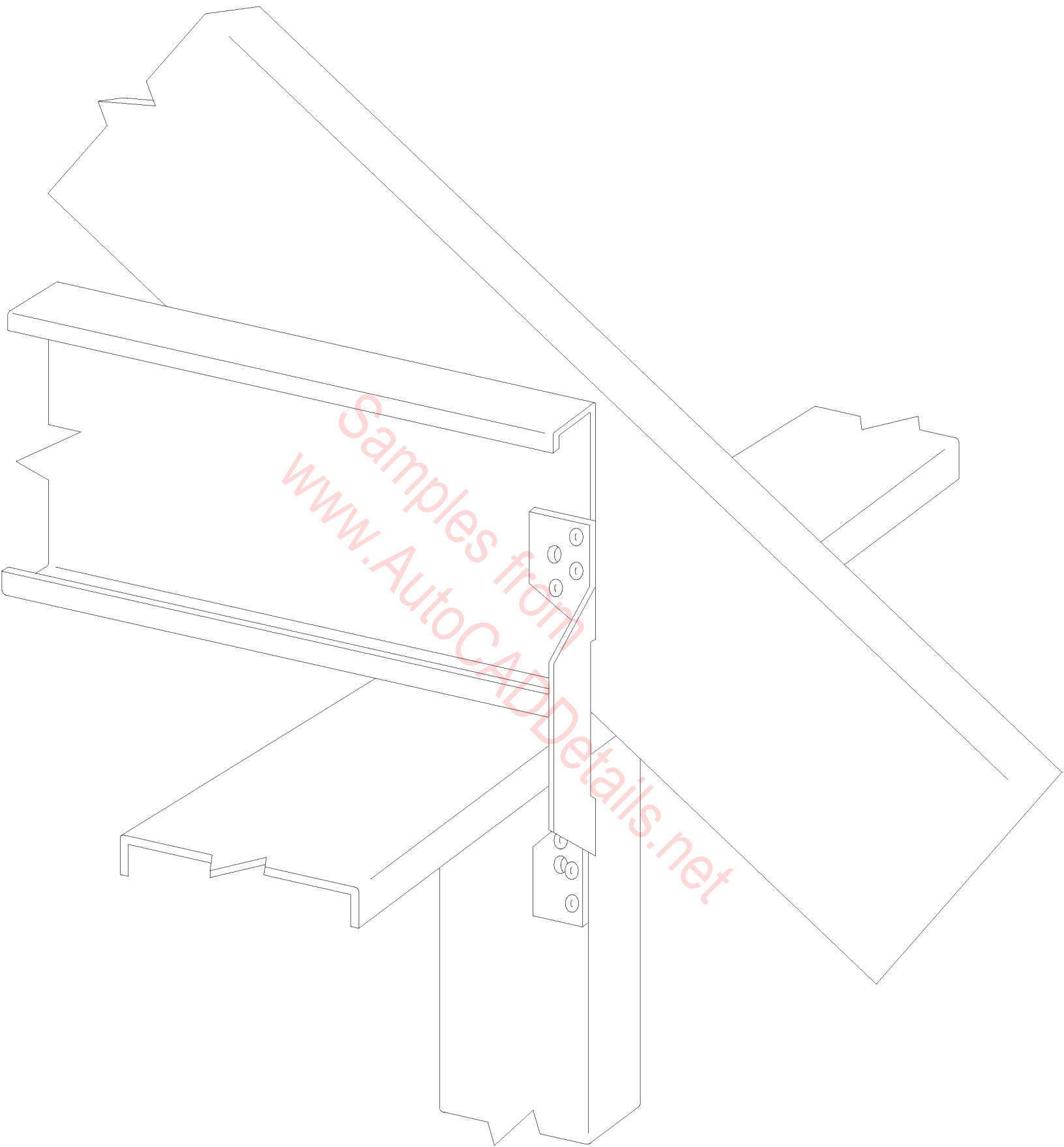

Simpson Strong-Tie  
S/H2

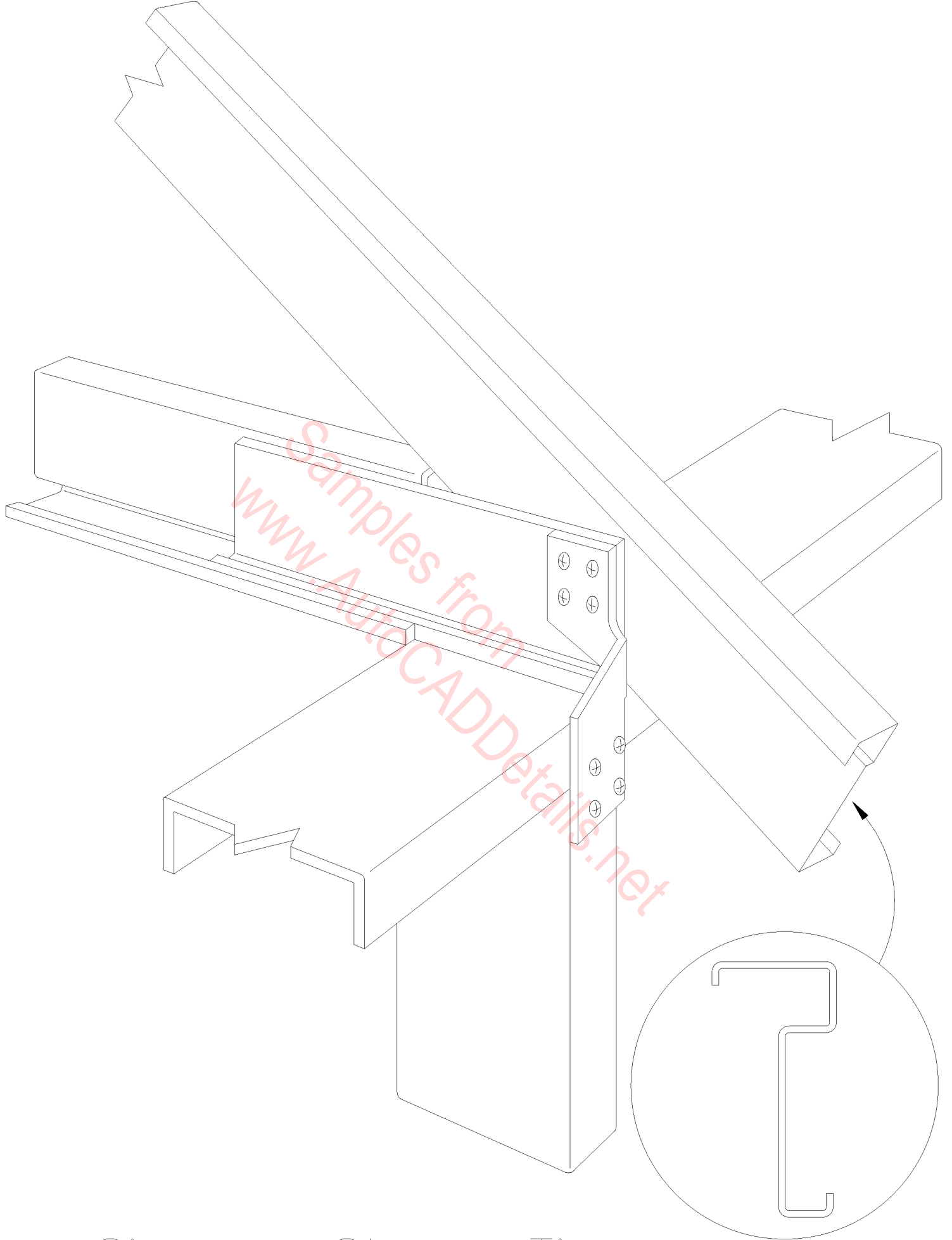

Simpson Strong-Tie  
S/H2.5

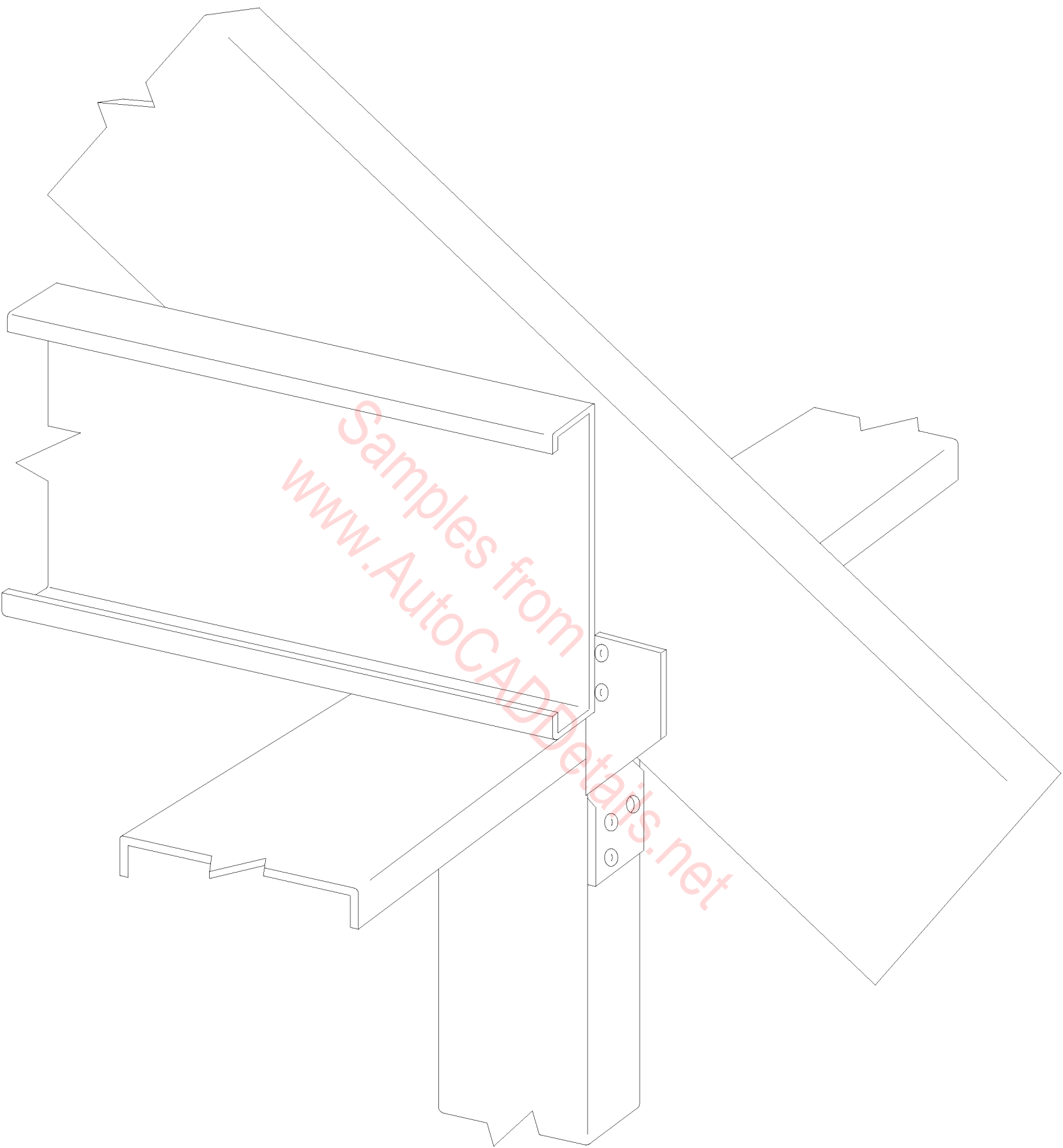

Simpson Strong-Tie  
S/H3

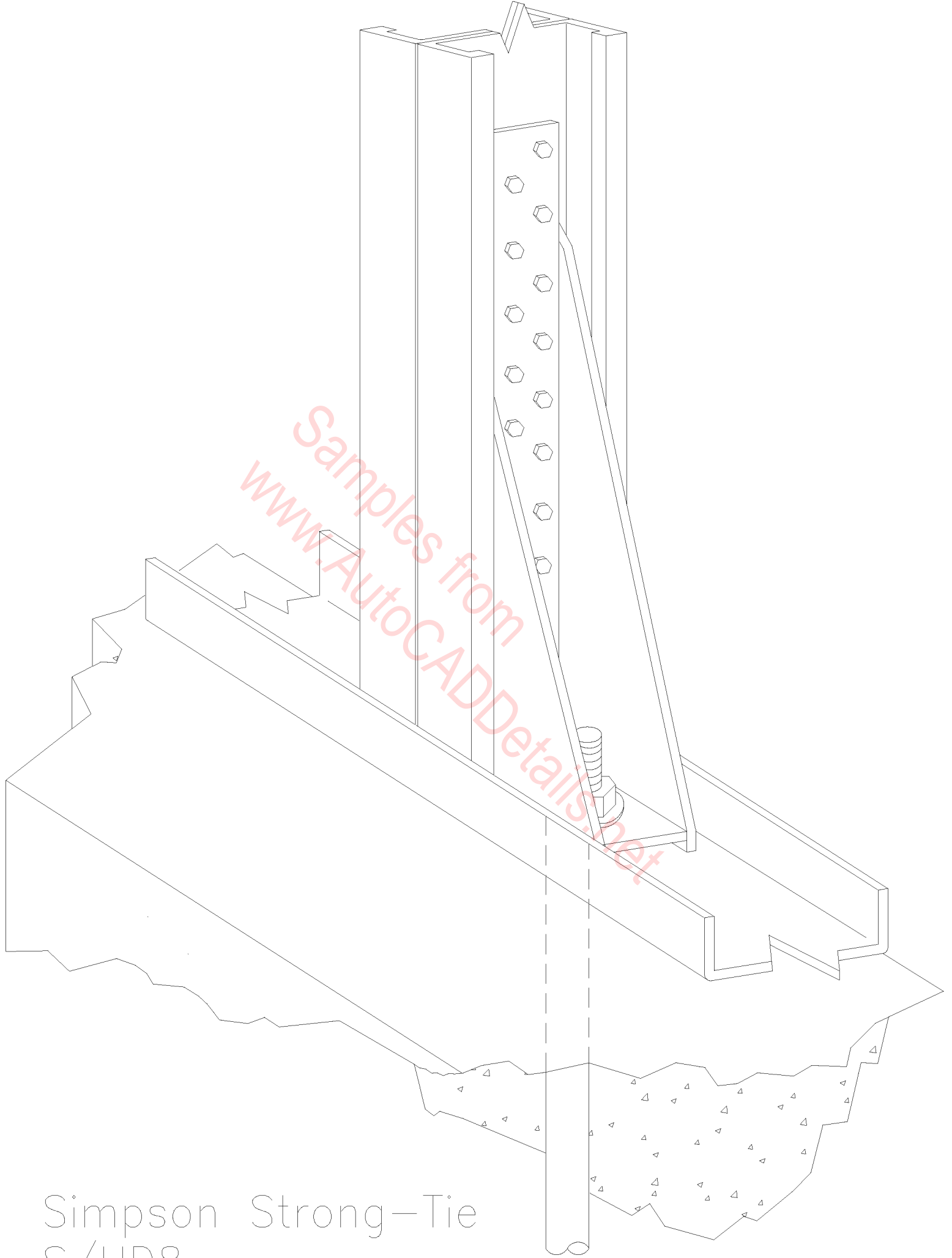

Simpson Strong-Tie  
S/HD8



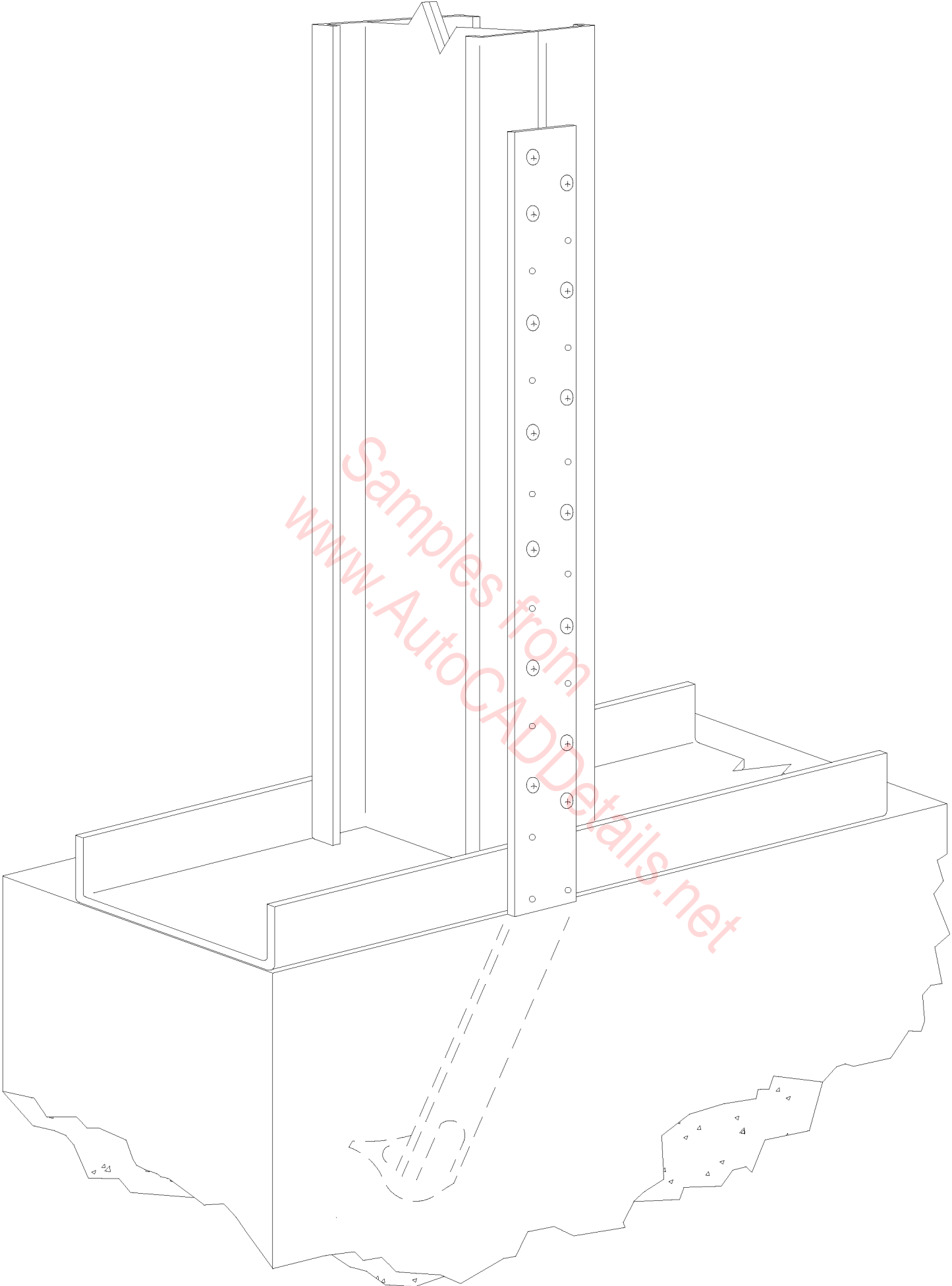

Simpson Strong-Tie  
S/HPAHD

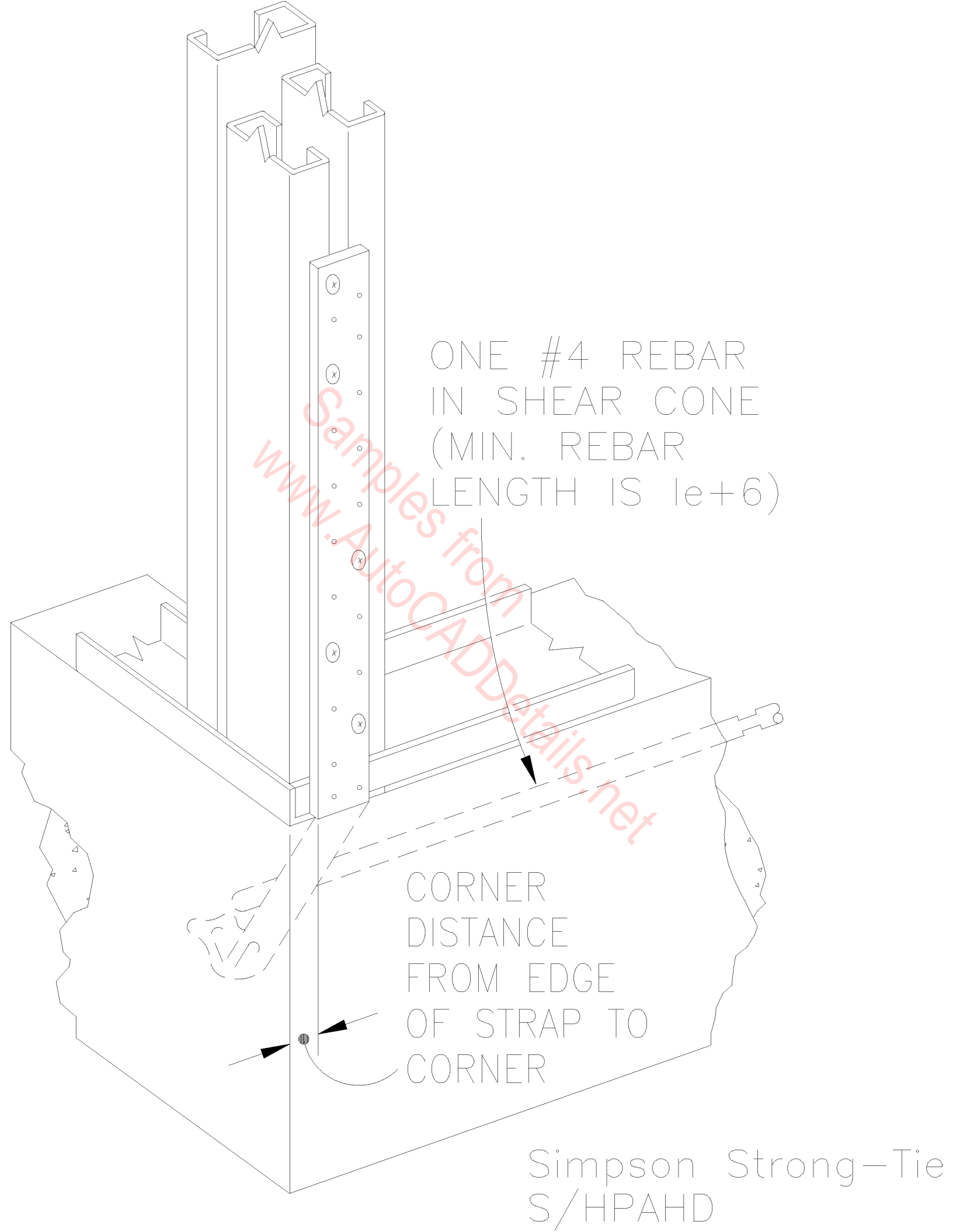

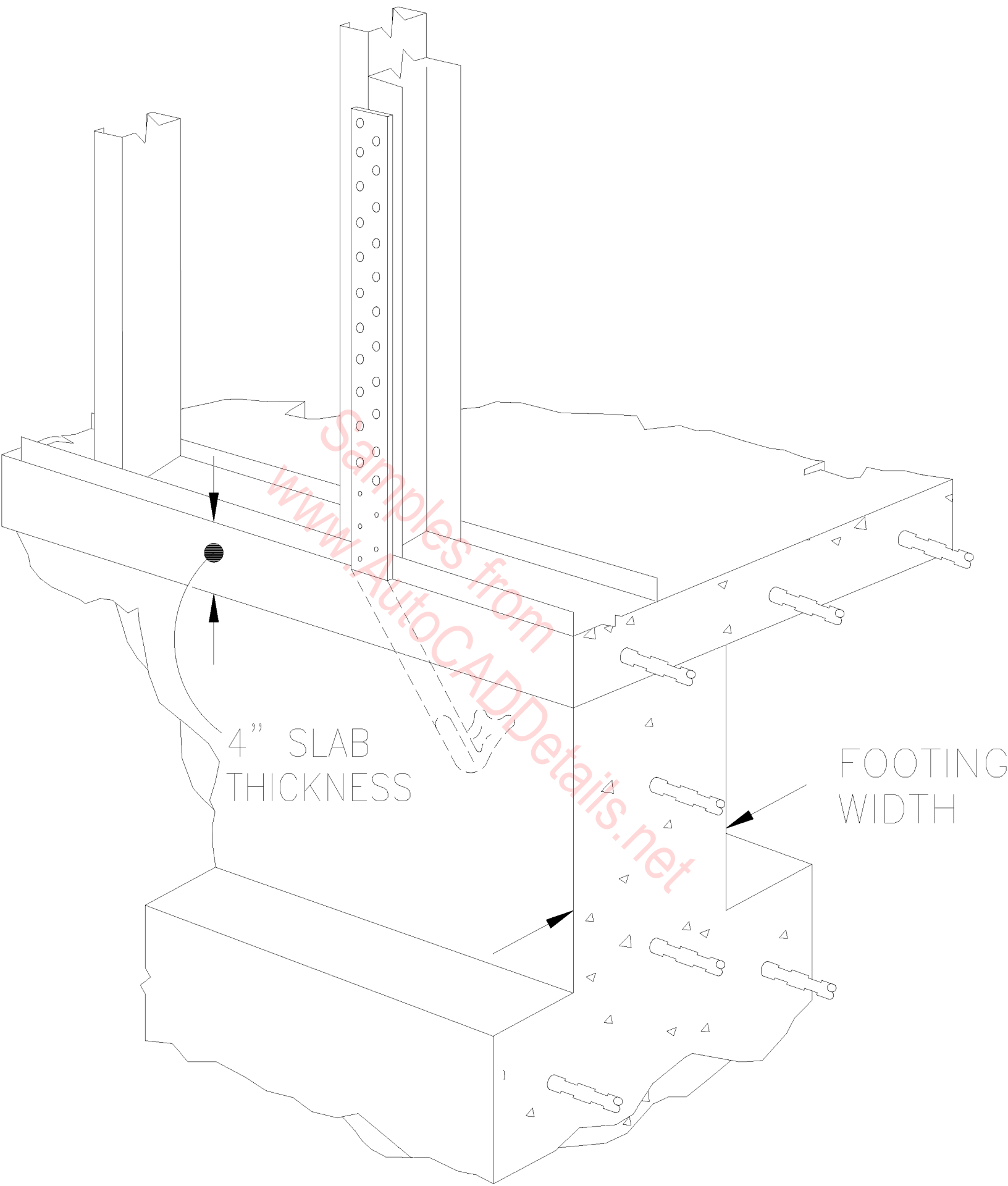

Simpson Strong-Tie  
HPAHD22-2P

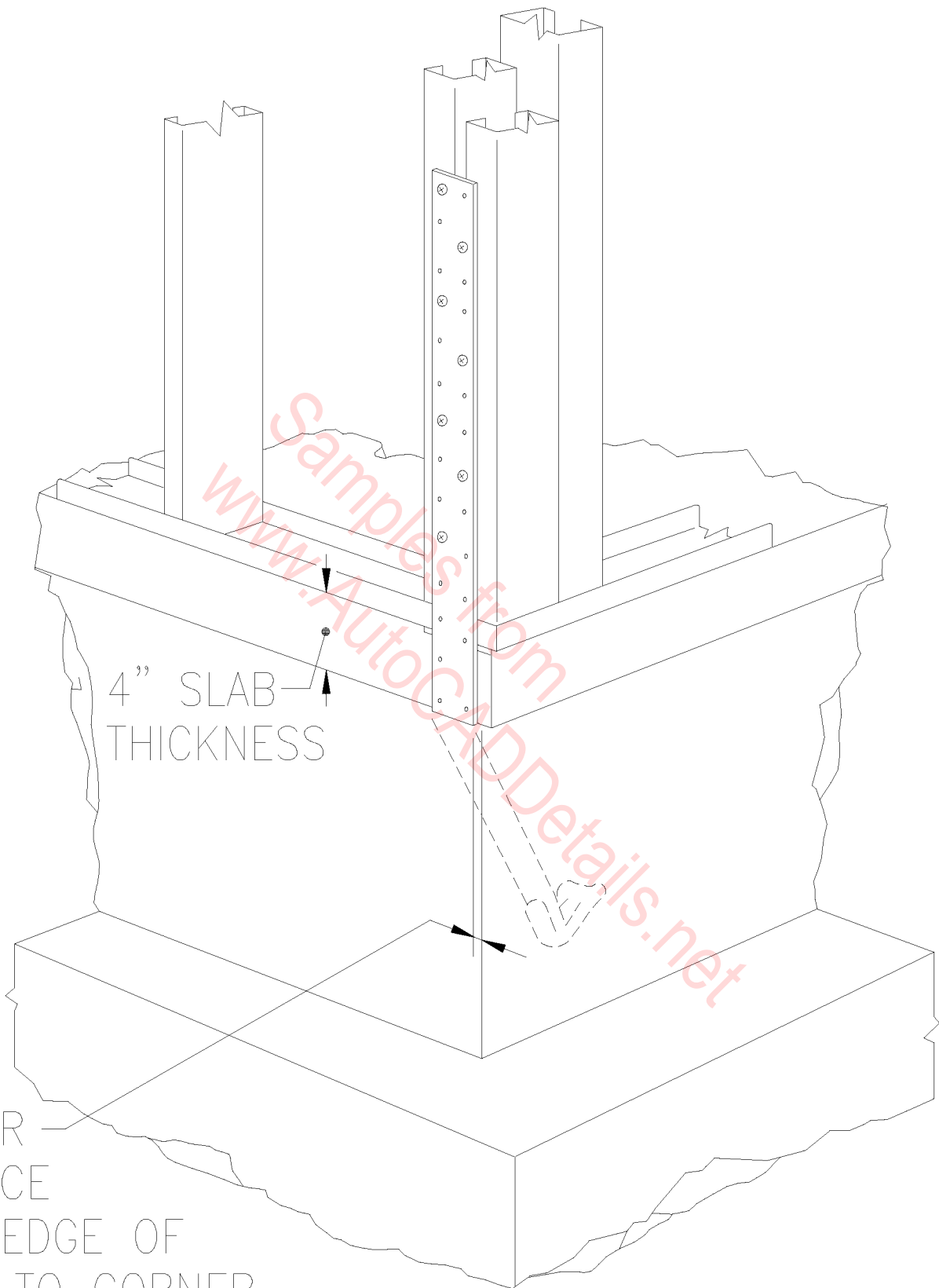

CORNER  
DISTANCE  
FROM EDGE OF  
STRAP TO CORNER

Simpson Strong-Tie  
S/HPAHD

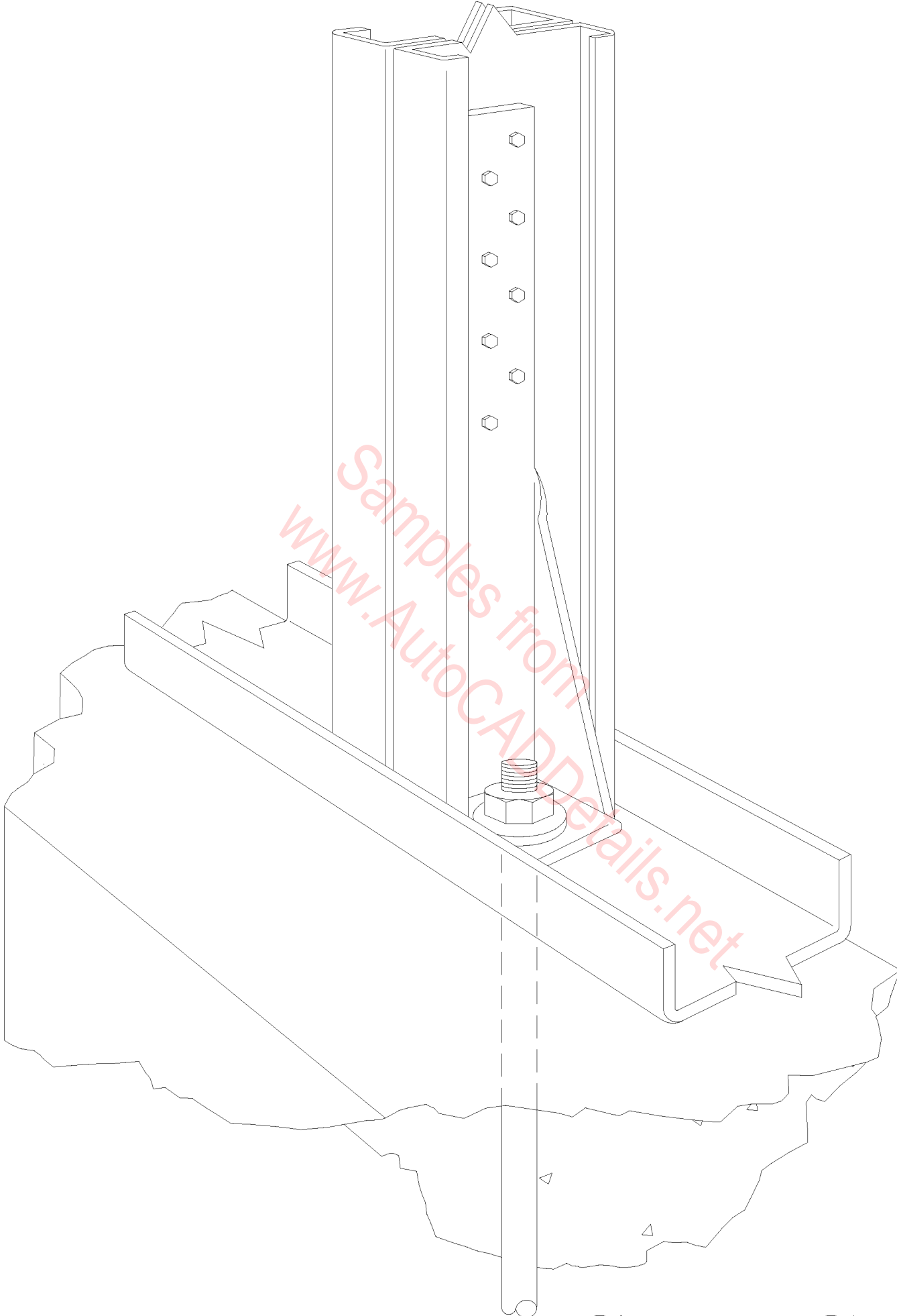

Simpson Strong-Tie  
S/HTT14

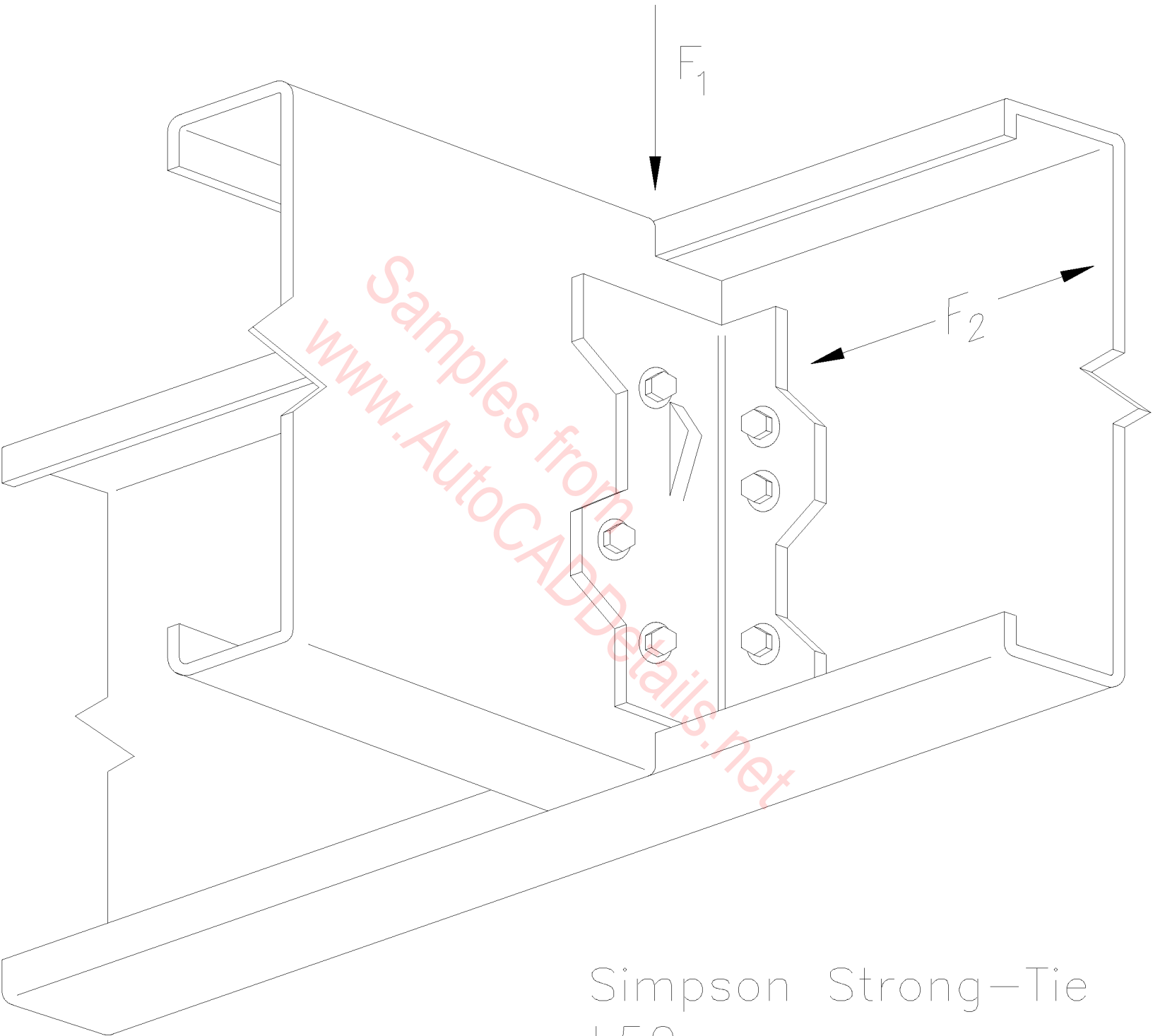

Simpson Strong-Tie  
L50

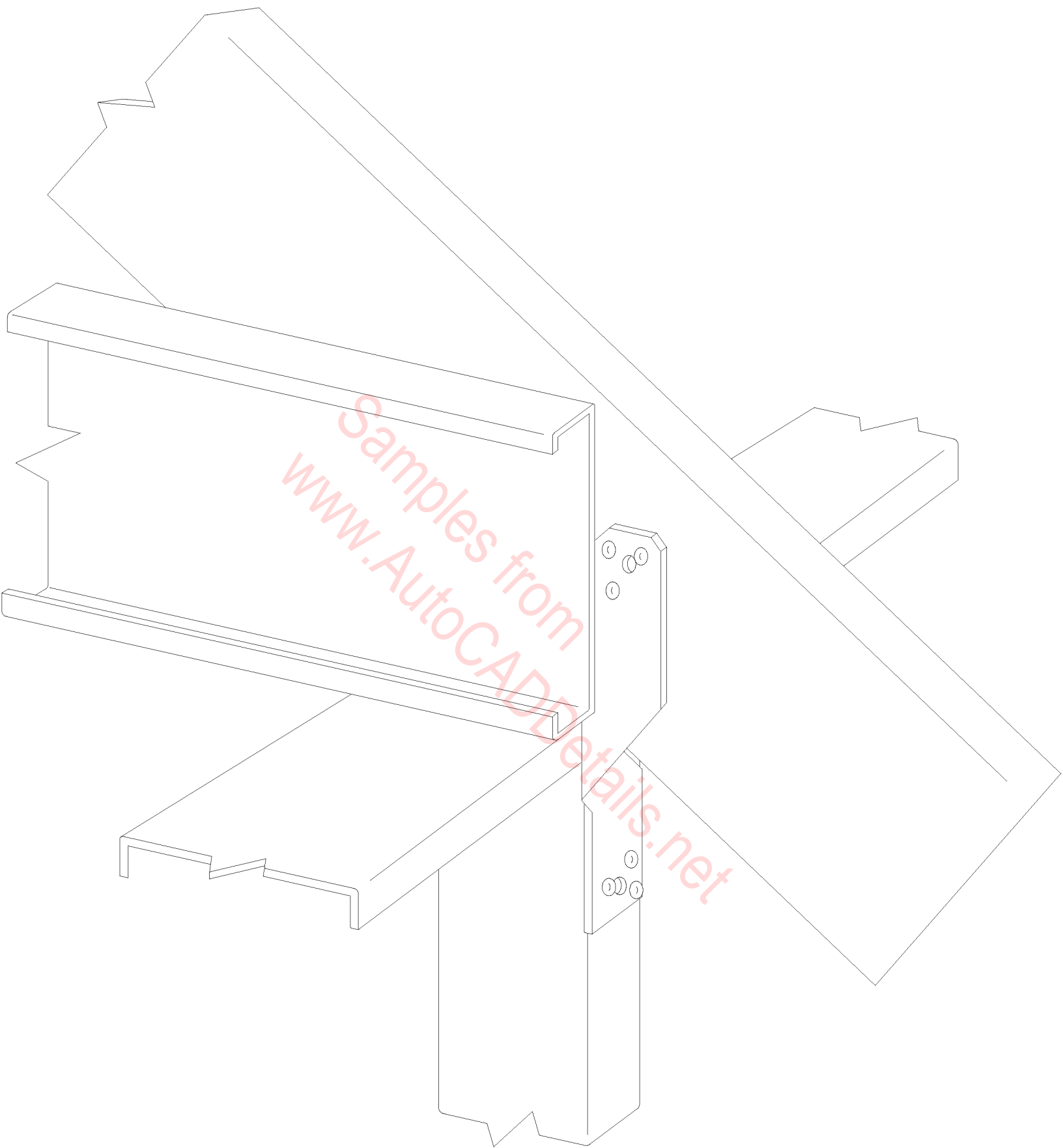

Simpson Strong-Tie  
S/LTS

5" MINIMUM LENGTH  
CHANNEL WITH  
TWO #8 SCREWS

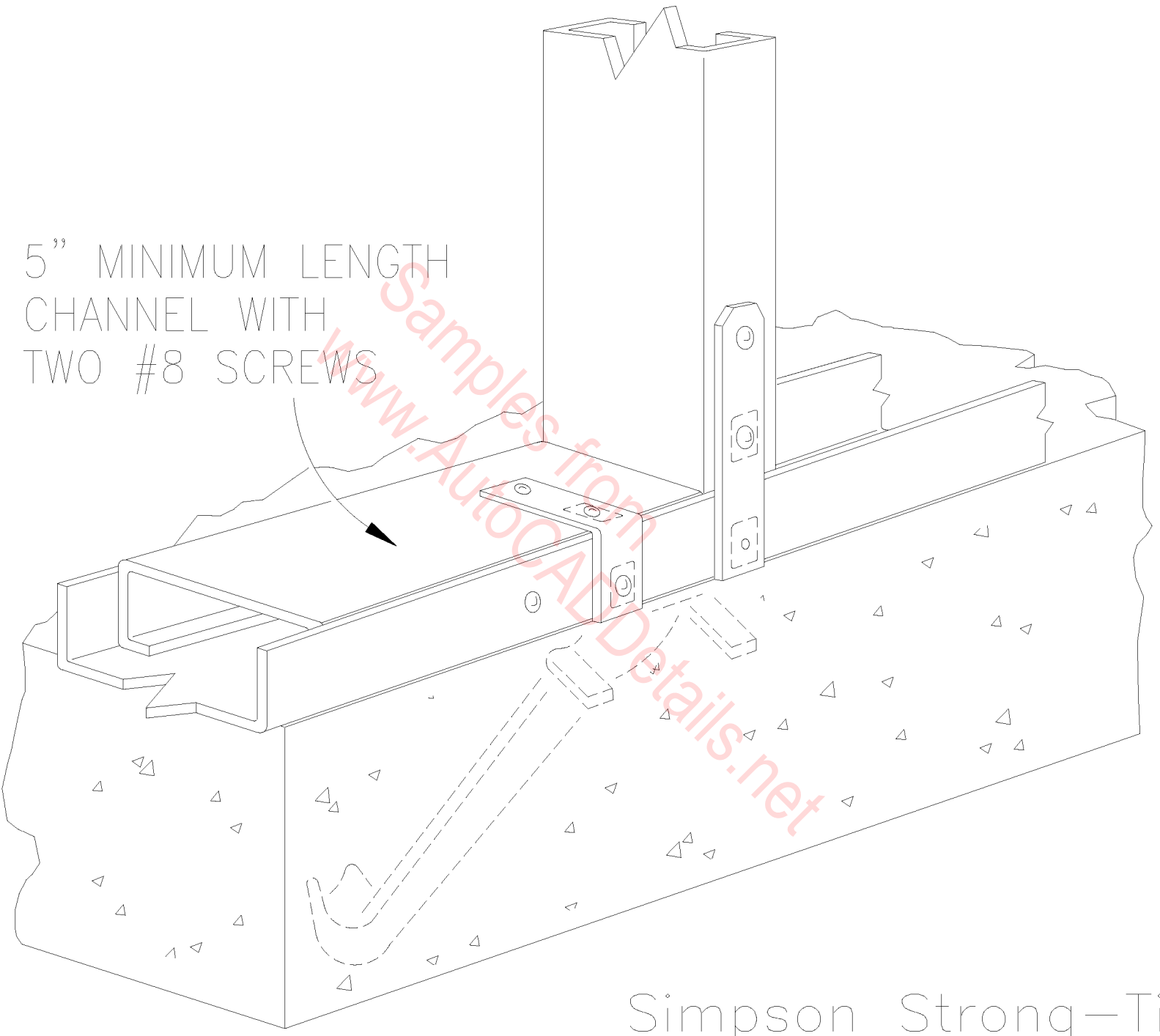

Simpson Strong-Tie  
MAS



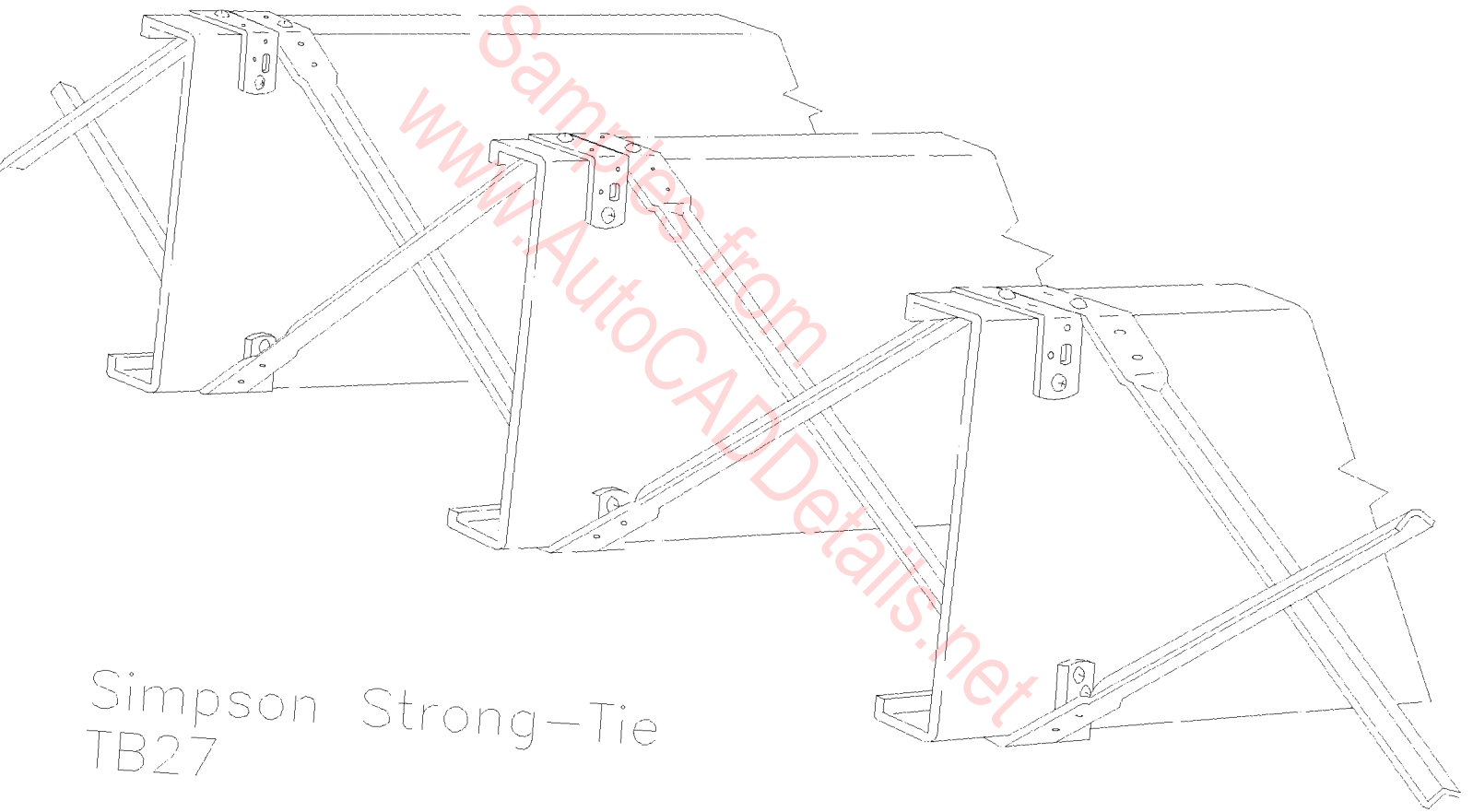

Simpson Strong-Tie  
TB27

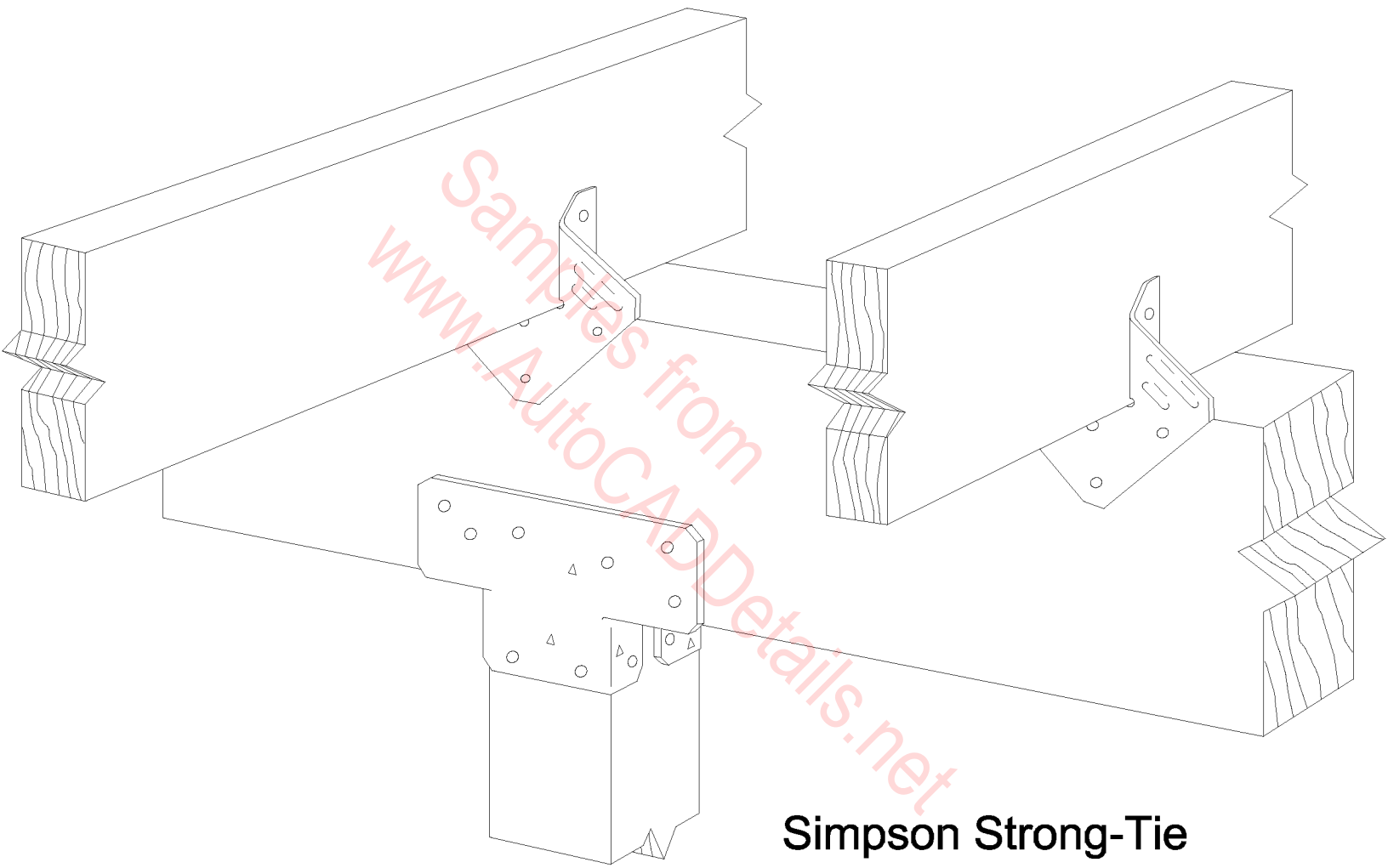

**Simpson Strong-Tie  
AC with two H1's  
Installation to Joist**

Use every other nail hole  
in a row to provide the  
code-required minimum  
center-to-center  
spacing for nails

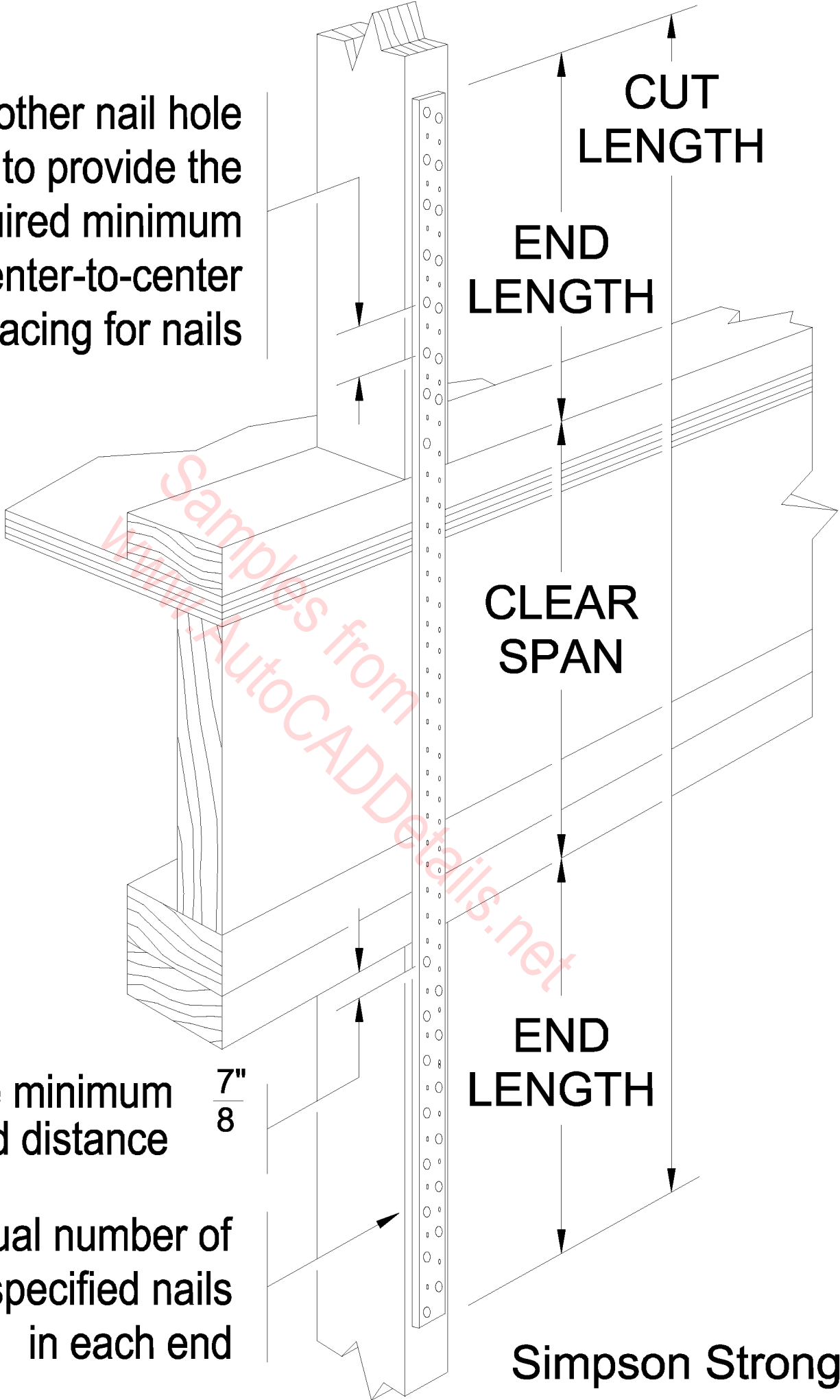

Provide minimum  
end distance  $\frac{7}{8}$

Equal number of  
specified nails  
in each end

Simpson Strong-Tie  
CS Coiled Strap

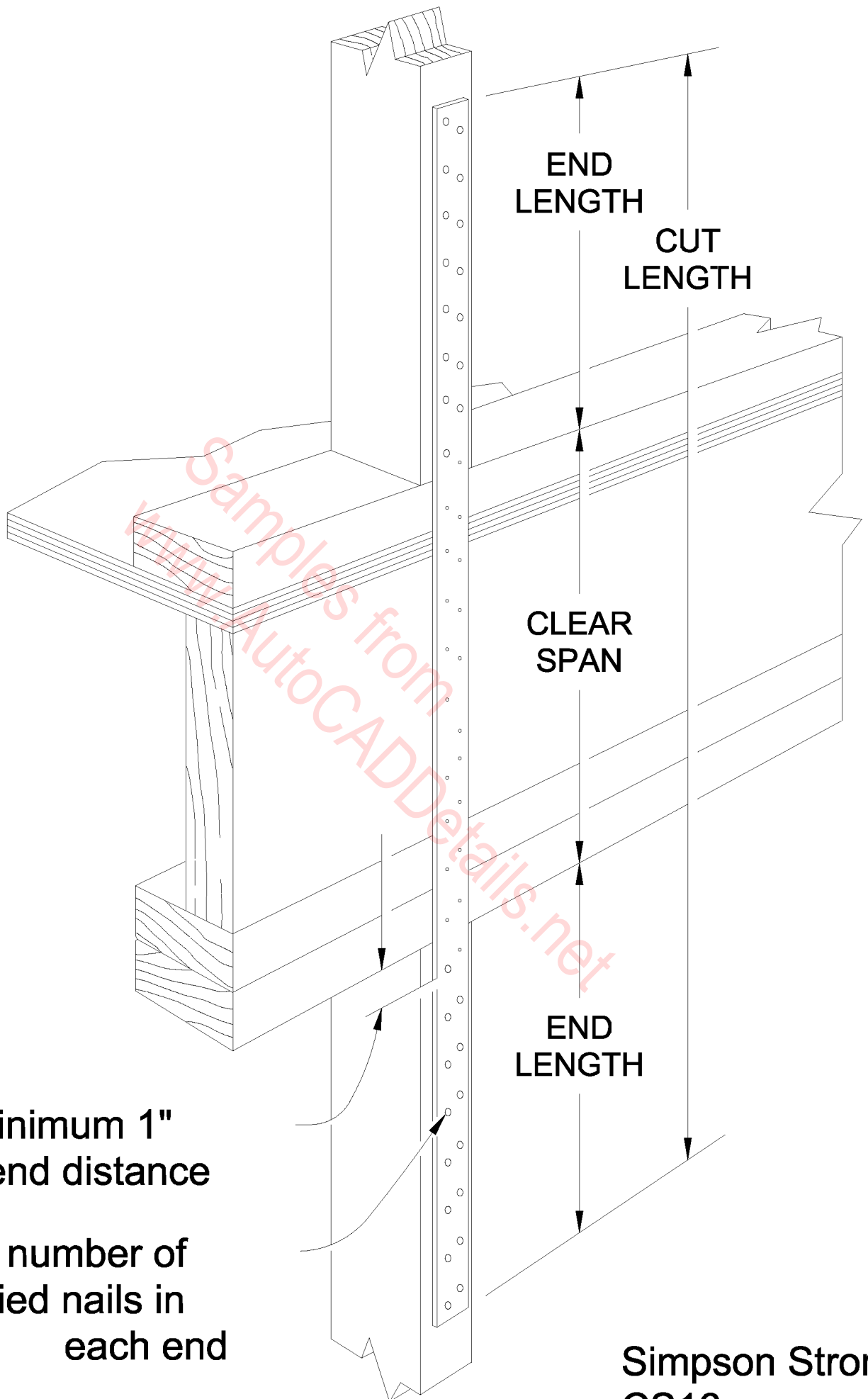

Provide minimum 1" end distance

Equal number of specified nails in each end

Simpson Strong-Tie  
CS16

**A23  
OPTIONAL**

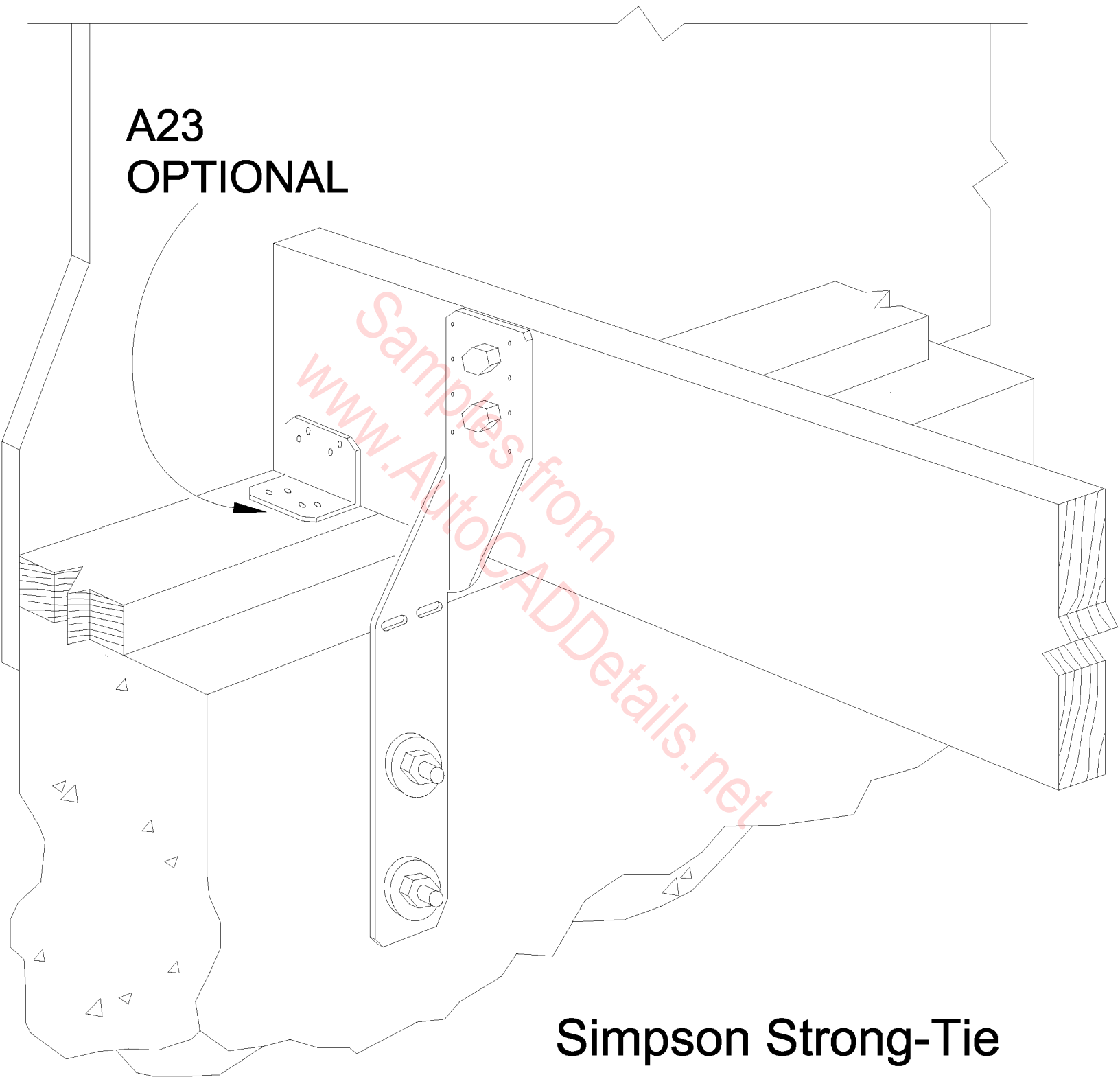

**Simpson Strong-Tie  
FJA**

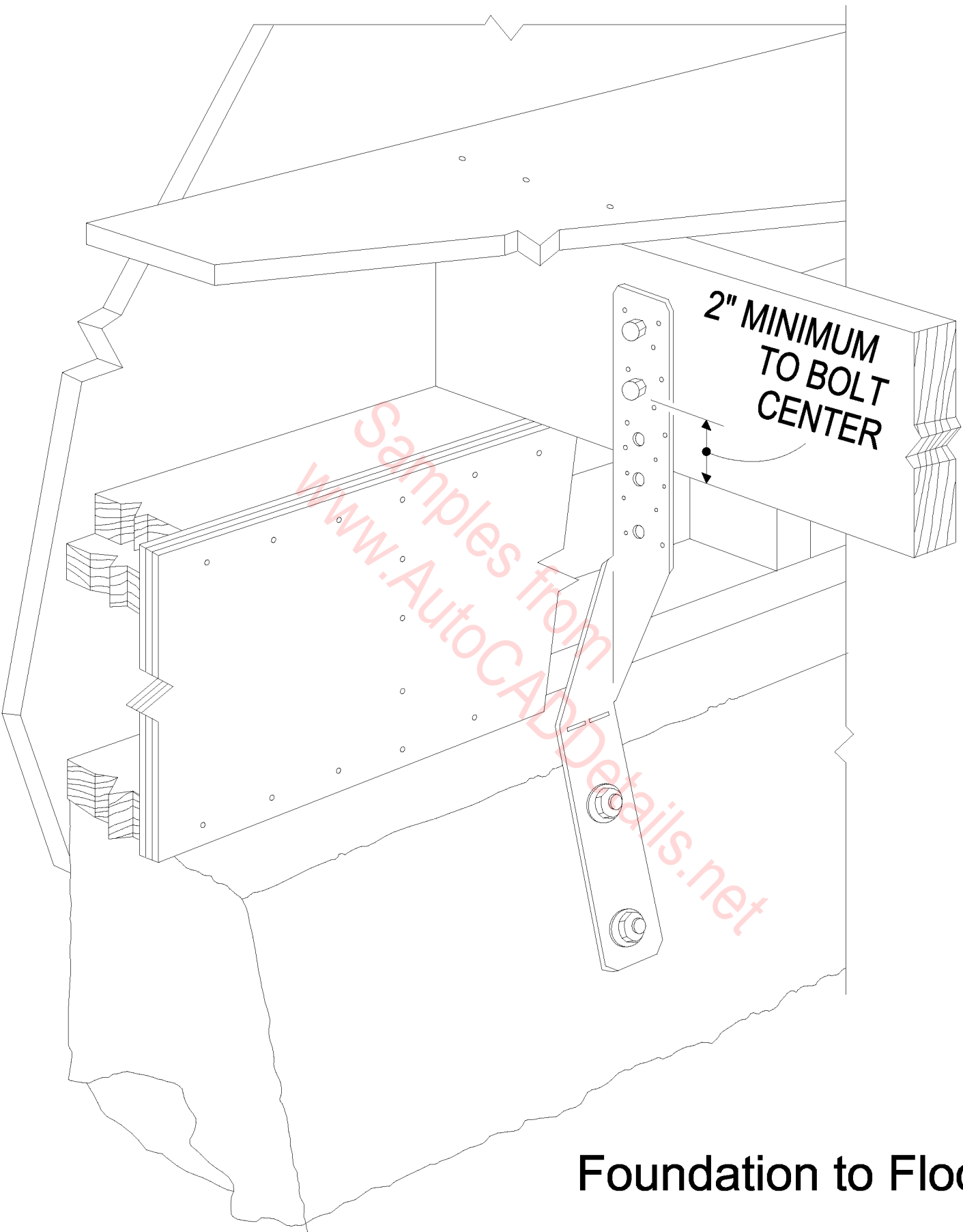

Foundation to Floor Joist

Simpson Strong-Tie  
FSA

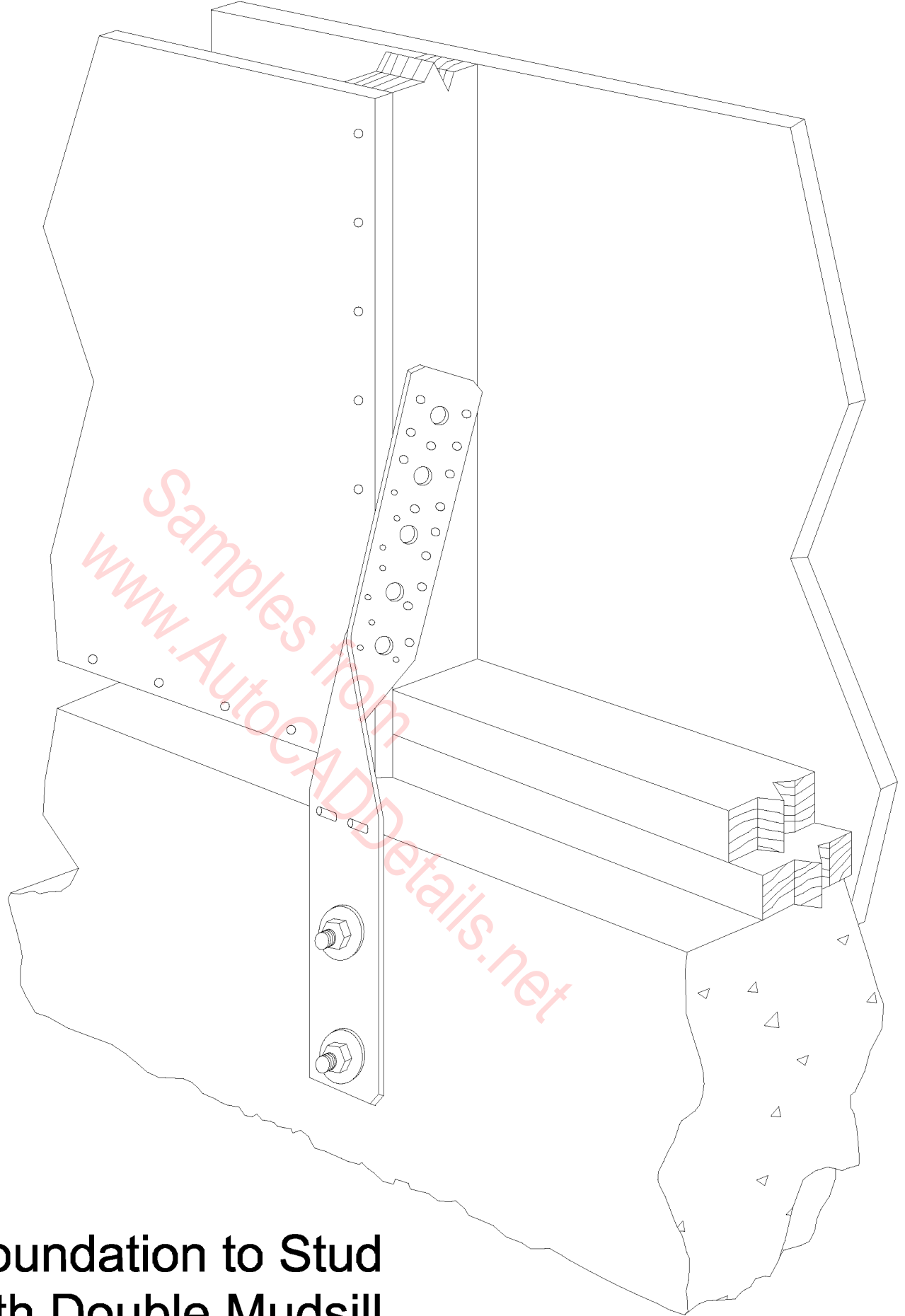

**Foundation to Stud  
with Double Mudsill**

**Simpson Strong-Tie  
FSA**

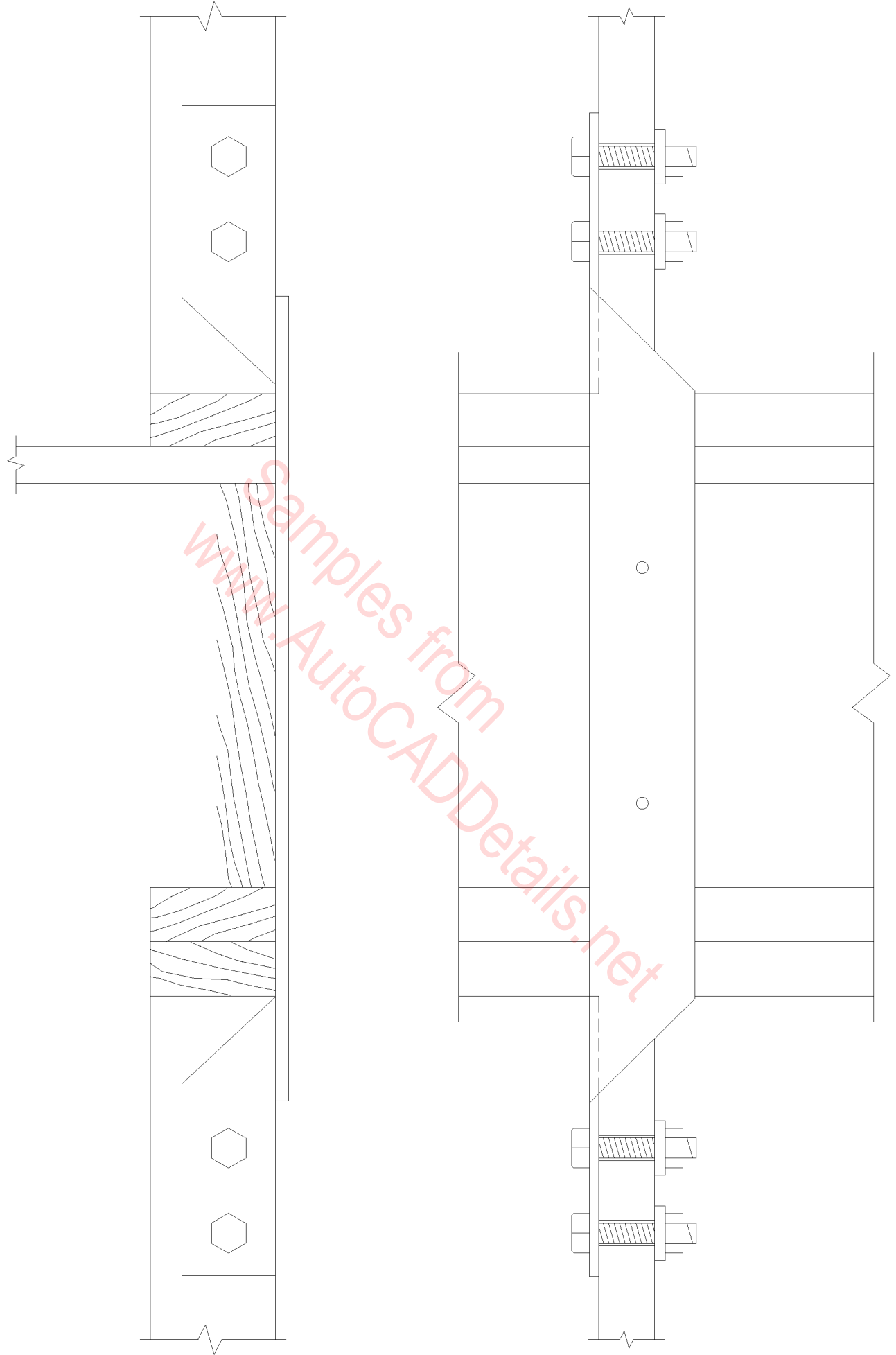

**Simpson Strong-Tie  
FTA**



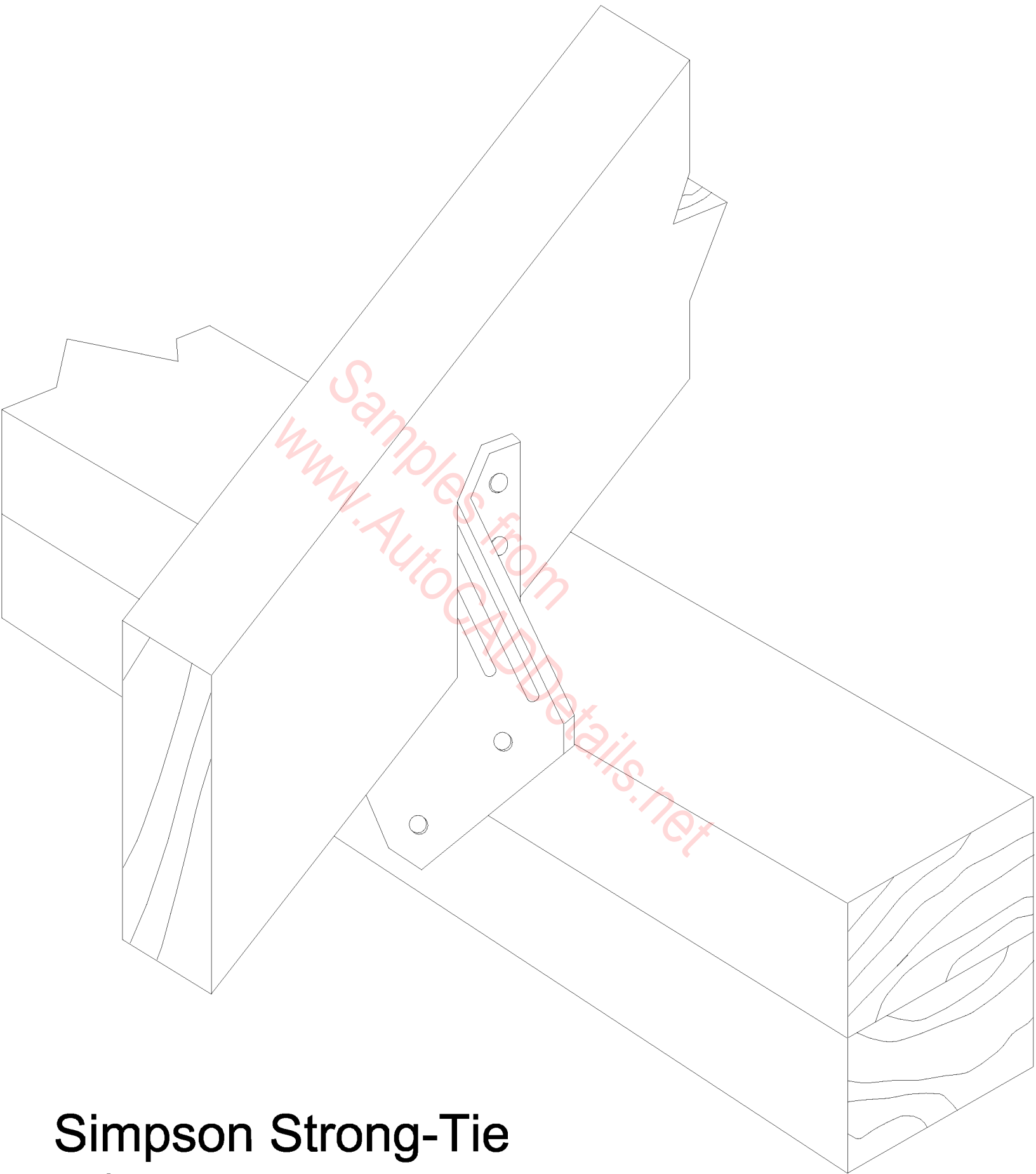

**Simpson Strong-Tie  
H1**

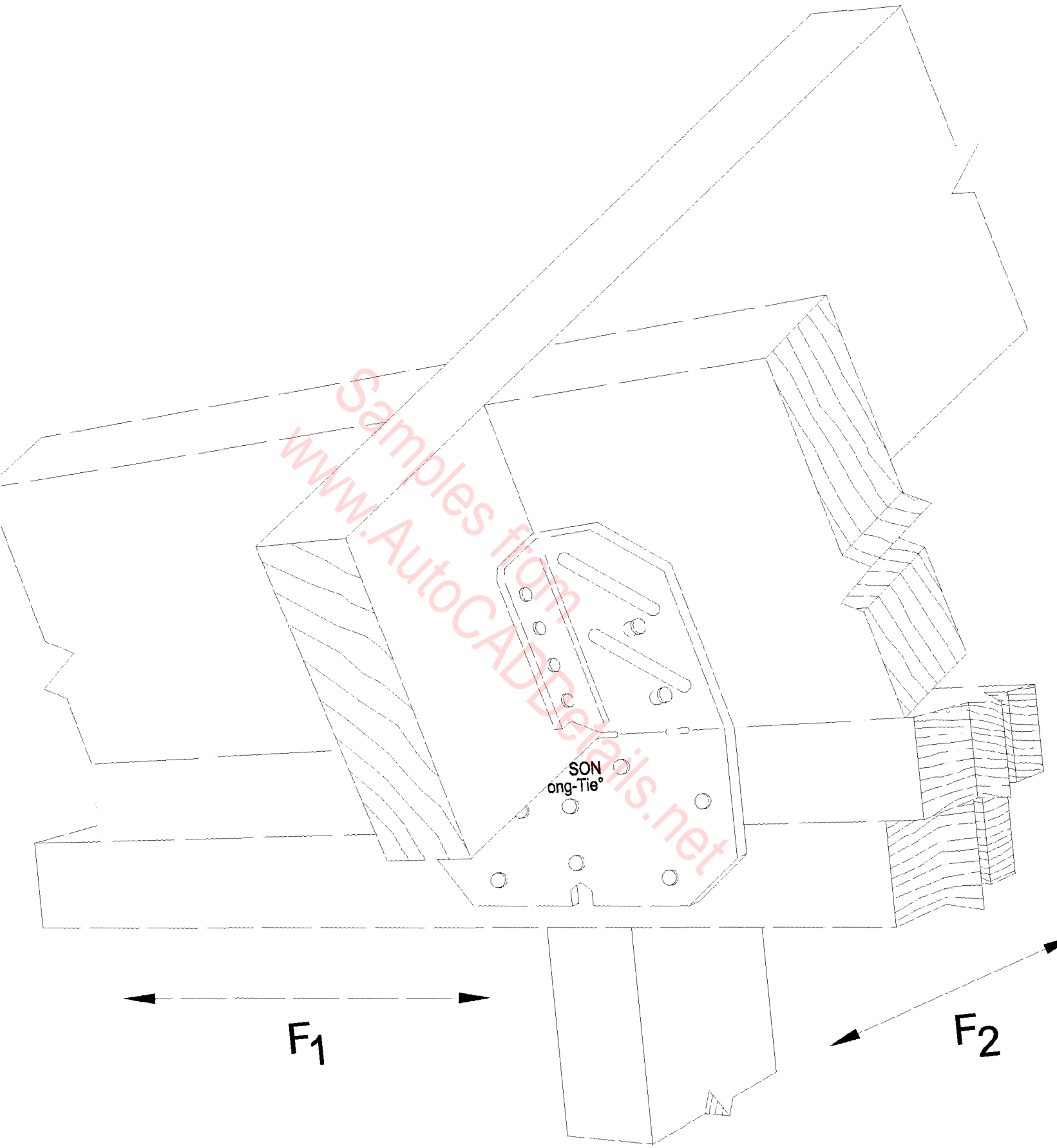

Simpson Strong-Tie  
H10

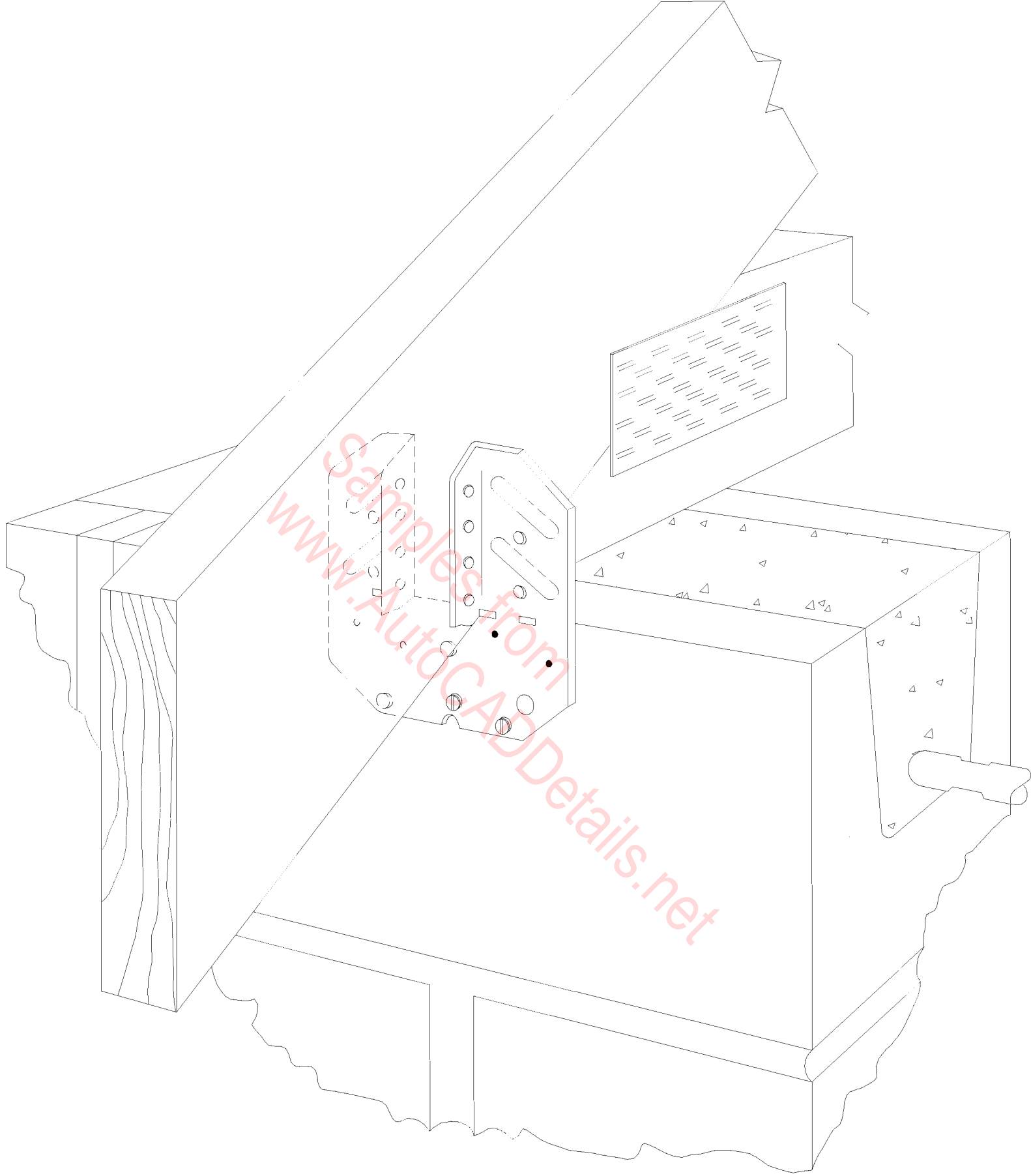

**Installed on Masonry with Tapcon Screws**

**Simpson Strong-Tie  
H10**

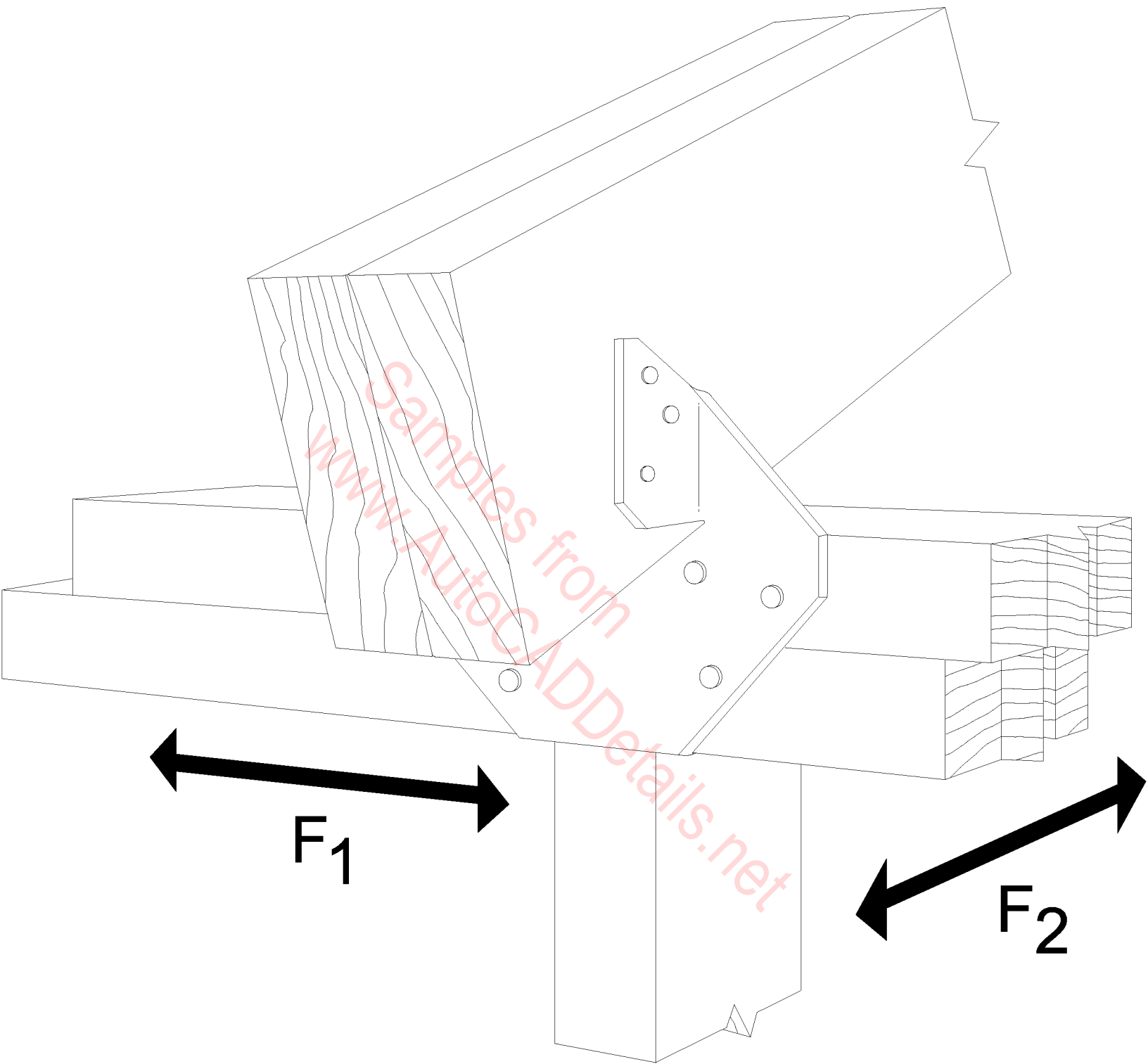

**Simpson Strong-Tie  
H10-2**

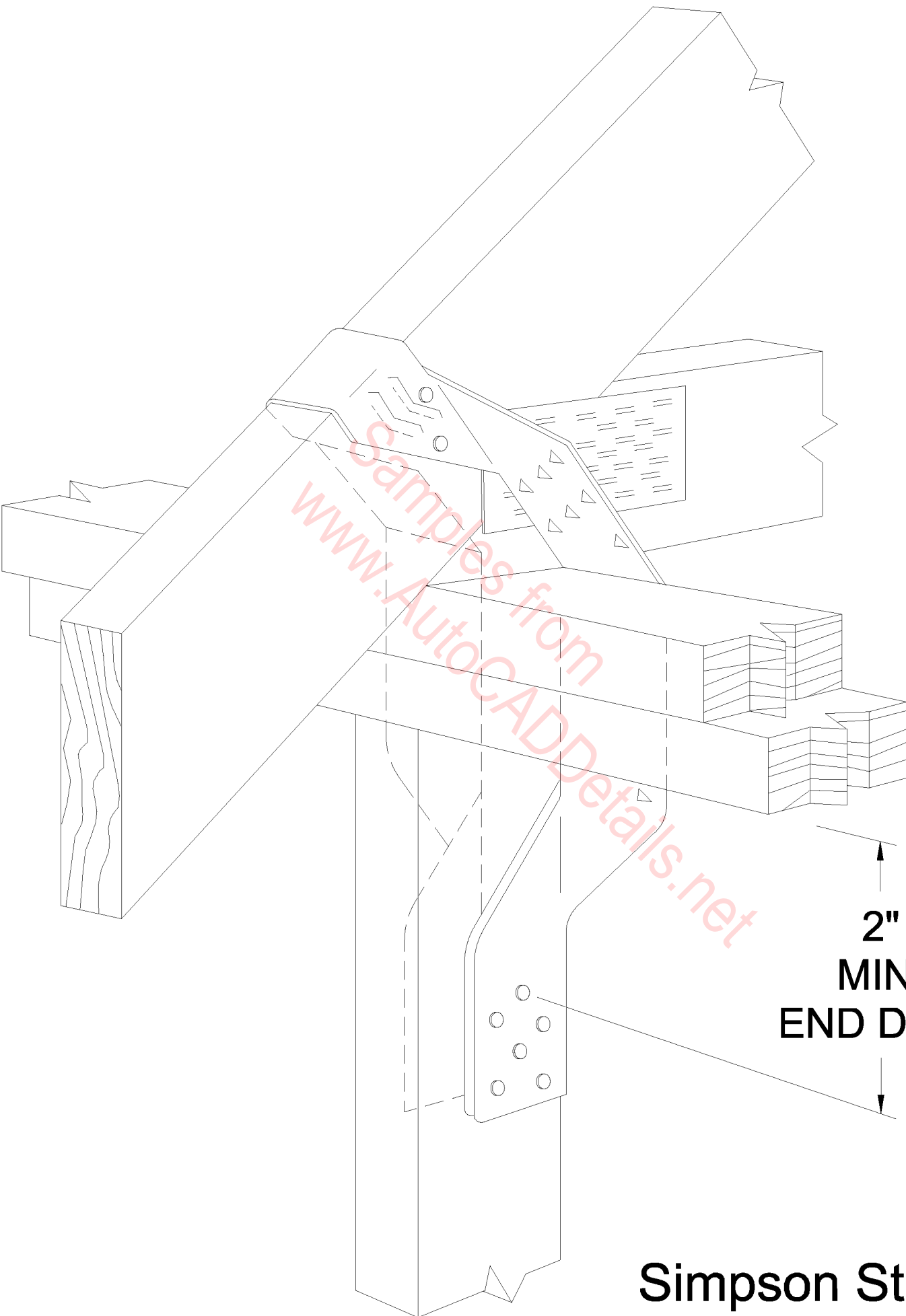

2"  
MIN.  
END DIST.

**Simpson Strong-Tie  
H15**

Samples from  
[www.AutoCADDetails.net](http://www.AutoCADDetails.net)

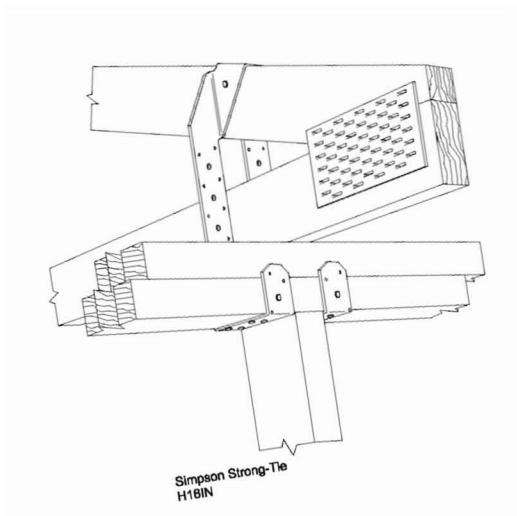

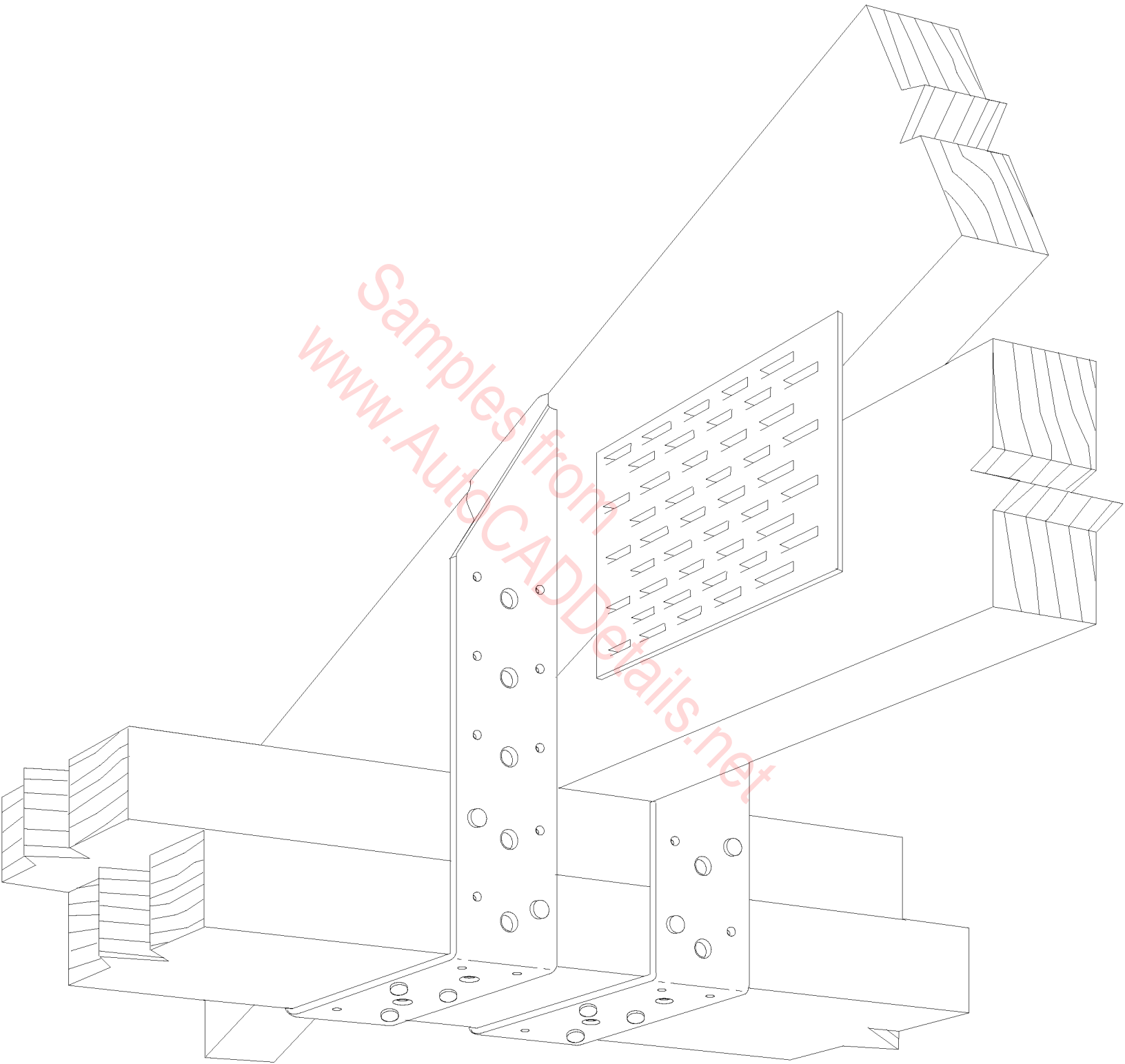

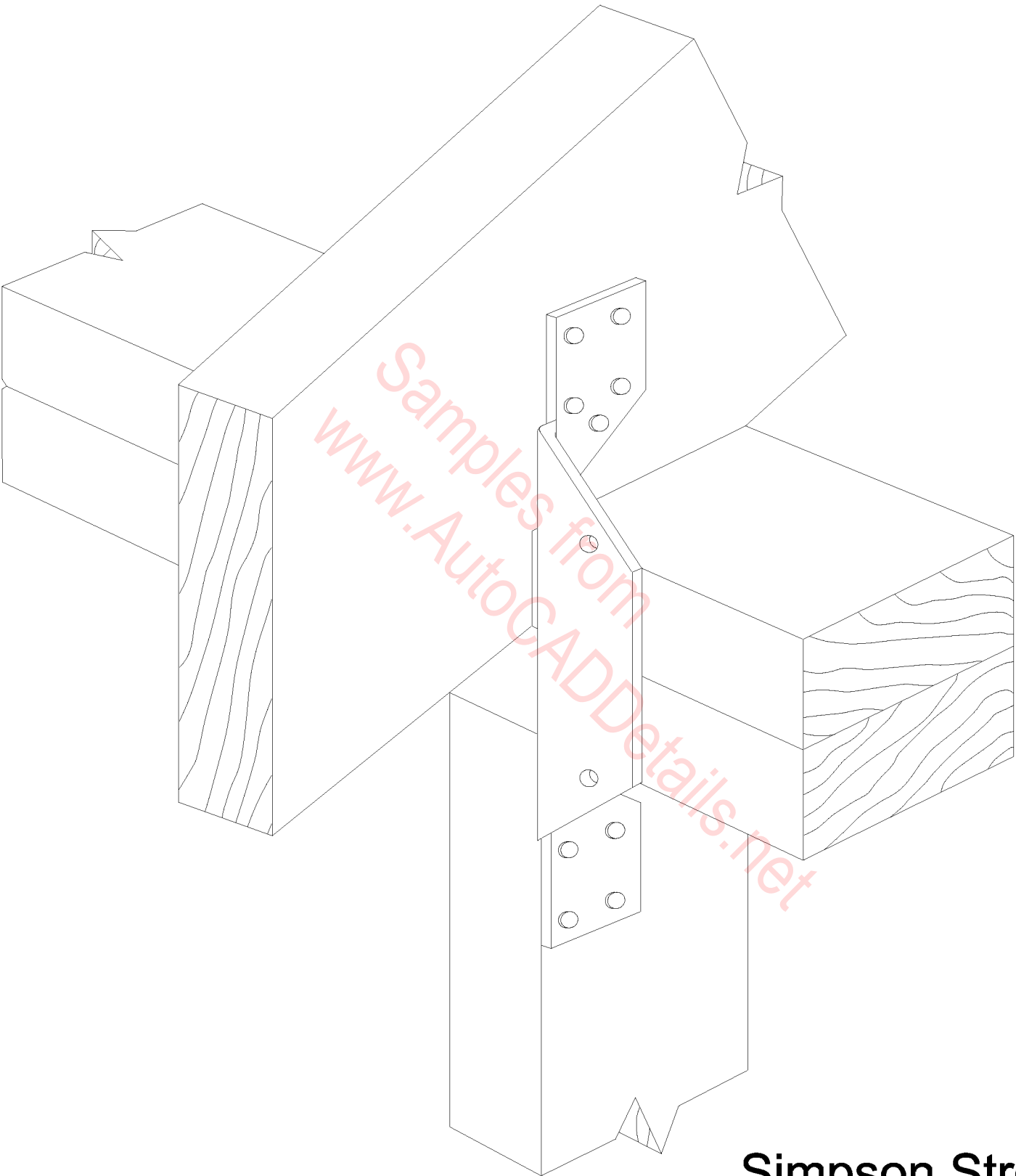

**Simpson Strong-Tie  
H2**



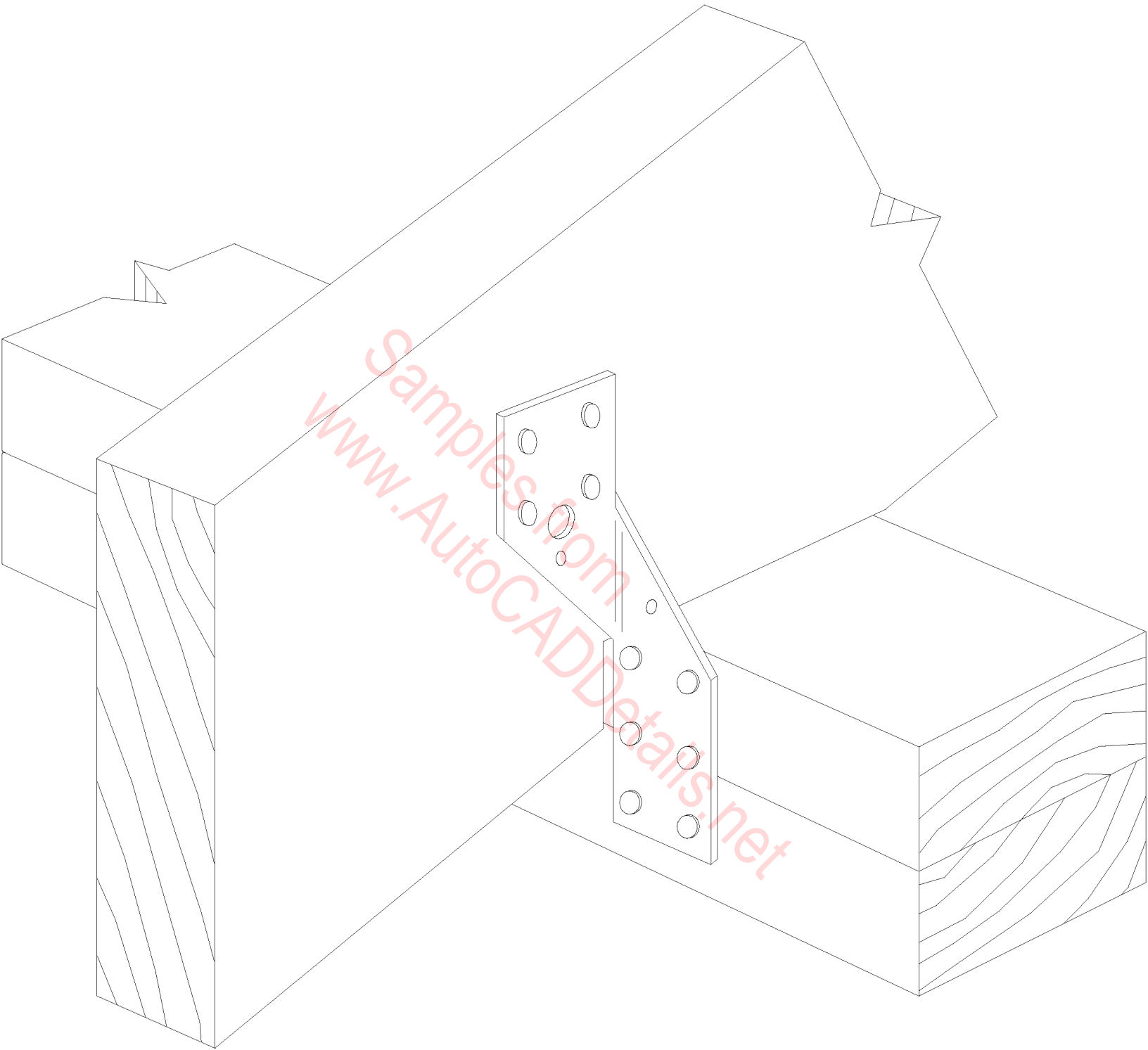

**Simpson Strong-Tie  
H2.5**

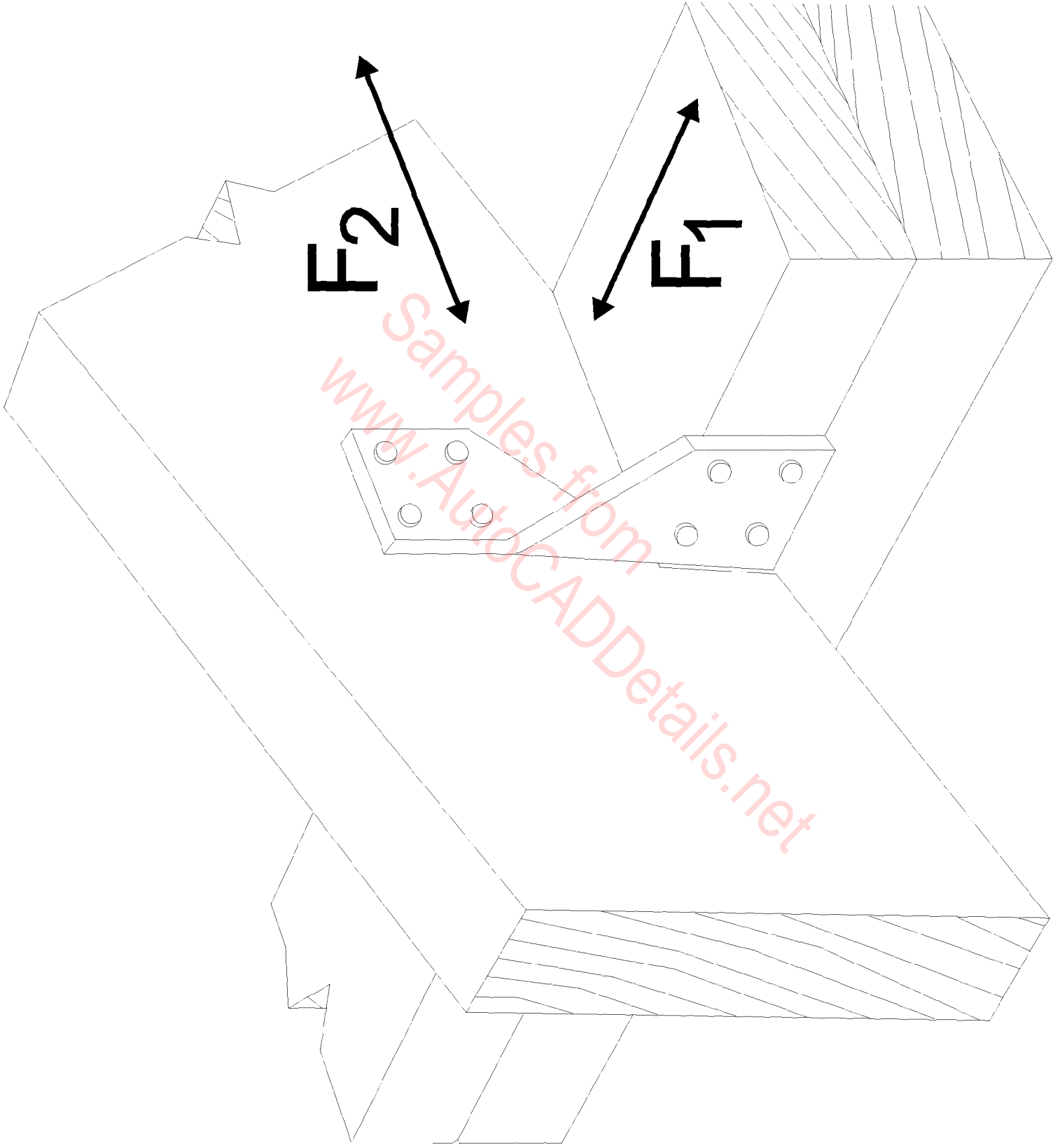

**Simpson Strong-Tie  
H3**

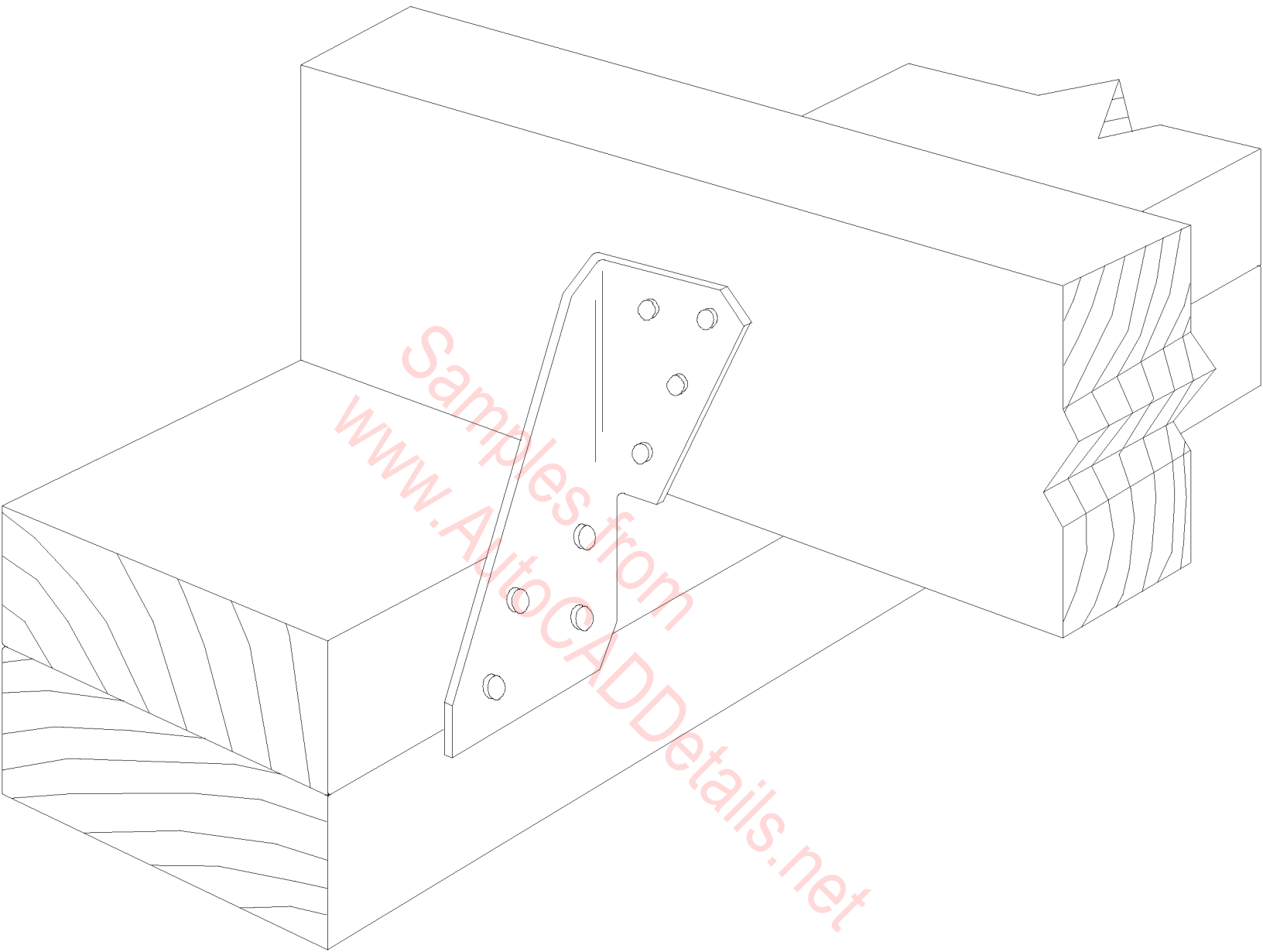

# Simpson Strong-Tie H4

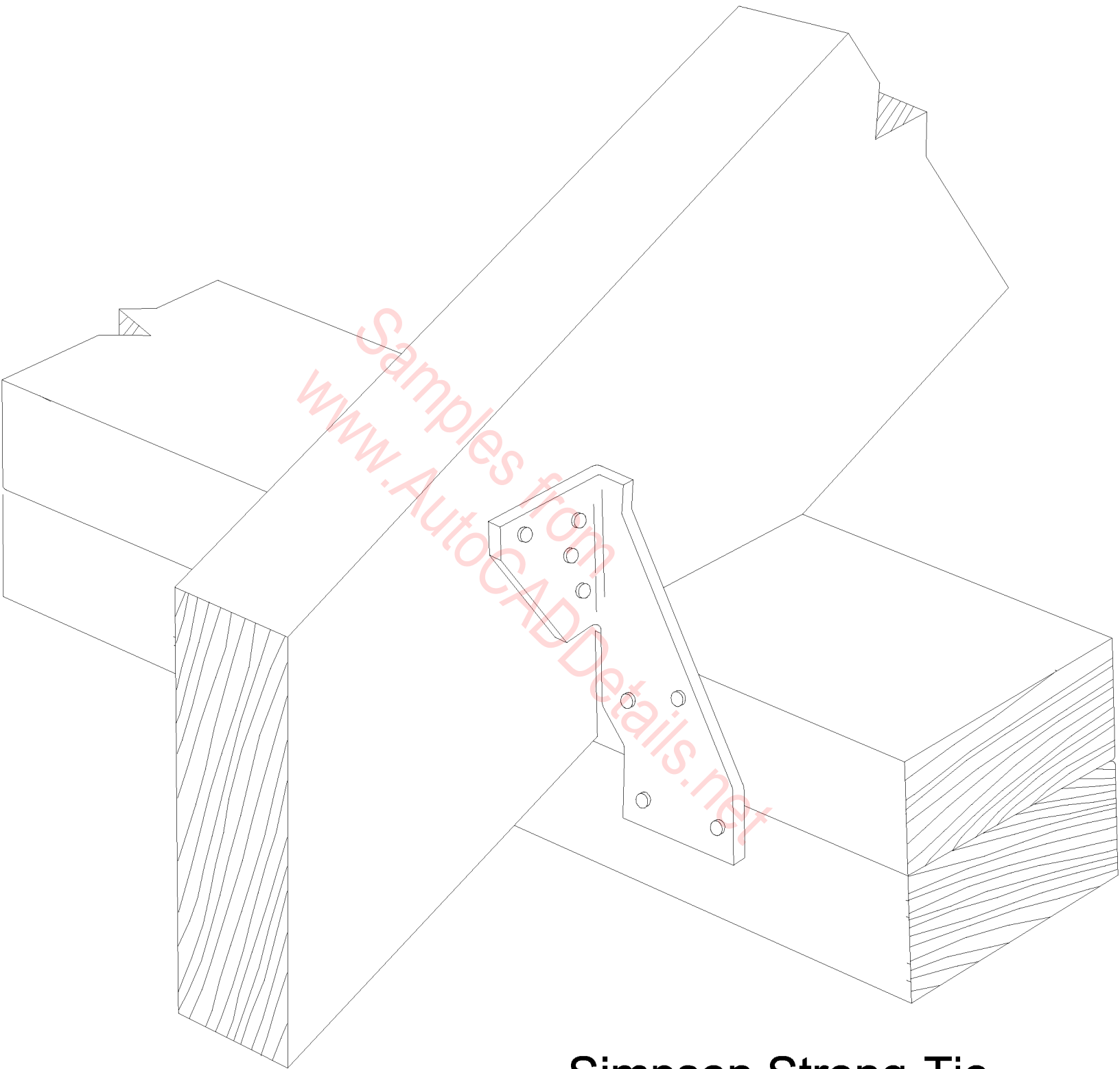

**Simpson Strong-Tie  
H5**

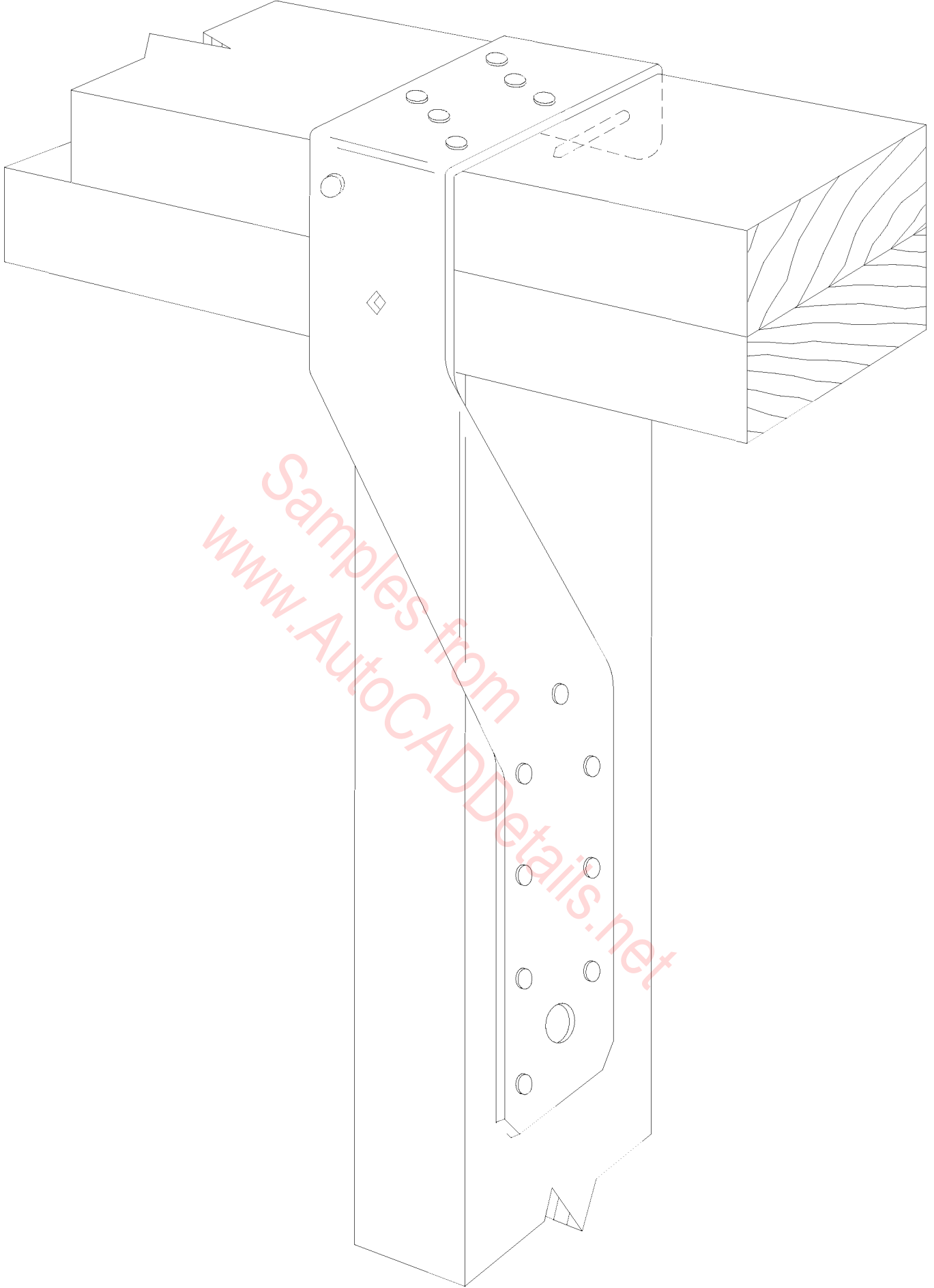

**Simpson Strong-Tie  
H6**

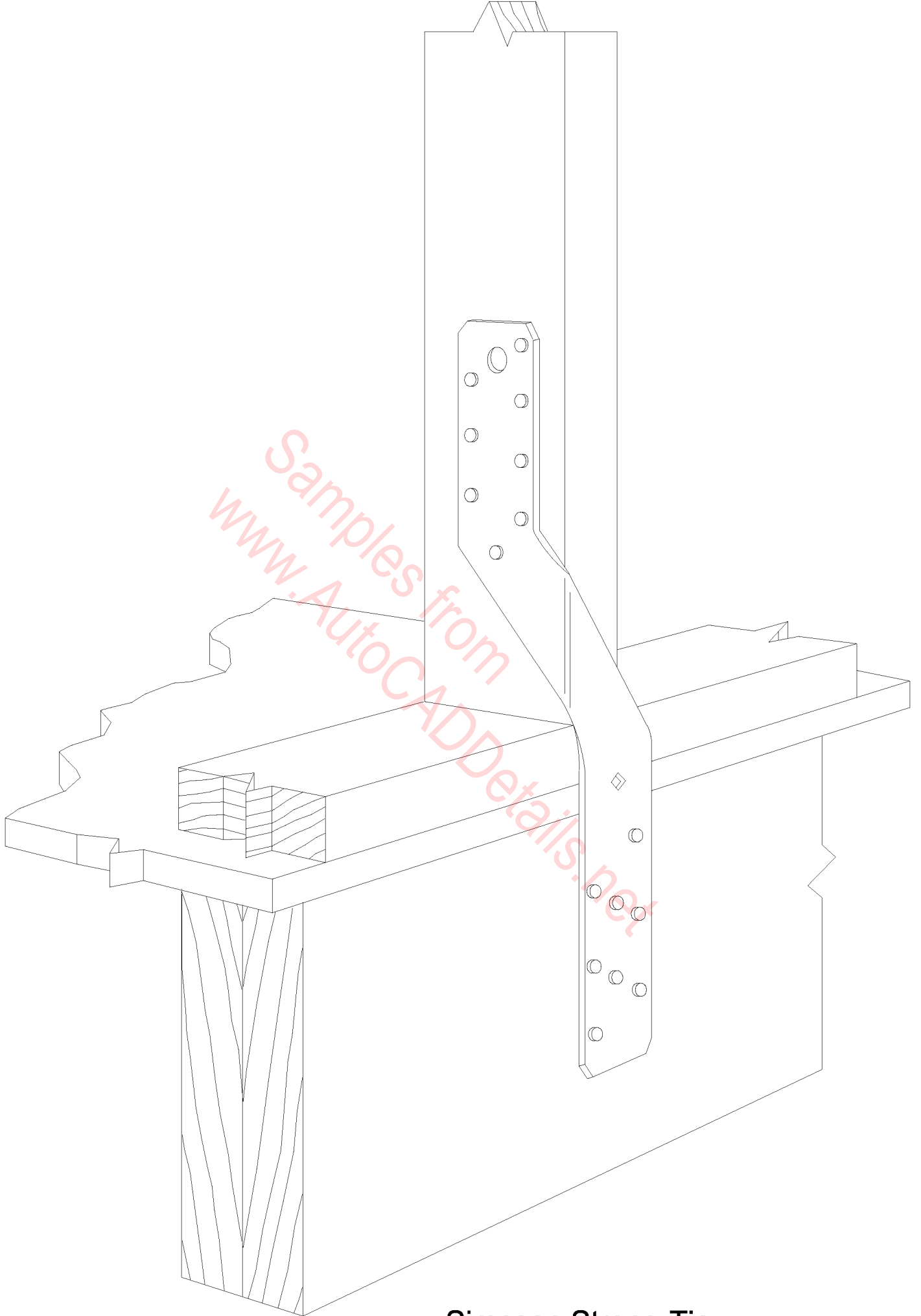

Simpson Strong-Tie  
H6

USE A MINIMUM OF  
TWO 8d NAILS THIS  
SIDE OF TRUSS.

TOTAL FOUR  
8d NAILS  
INTO TRUSS.

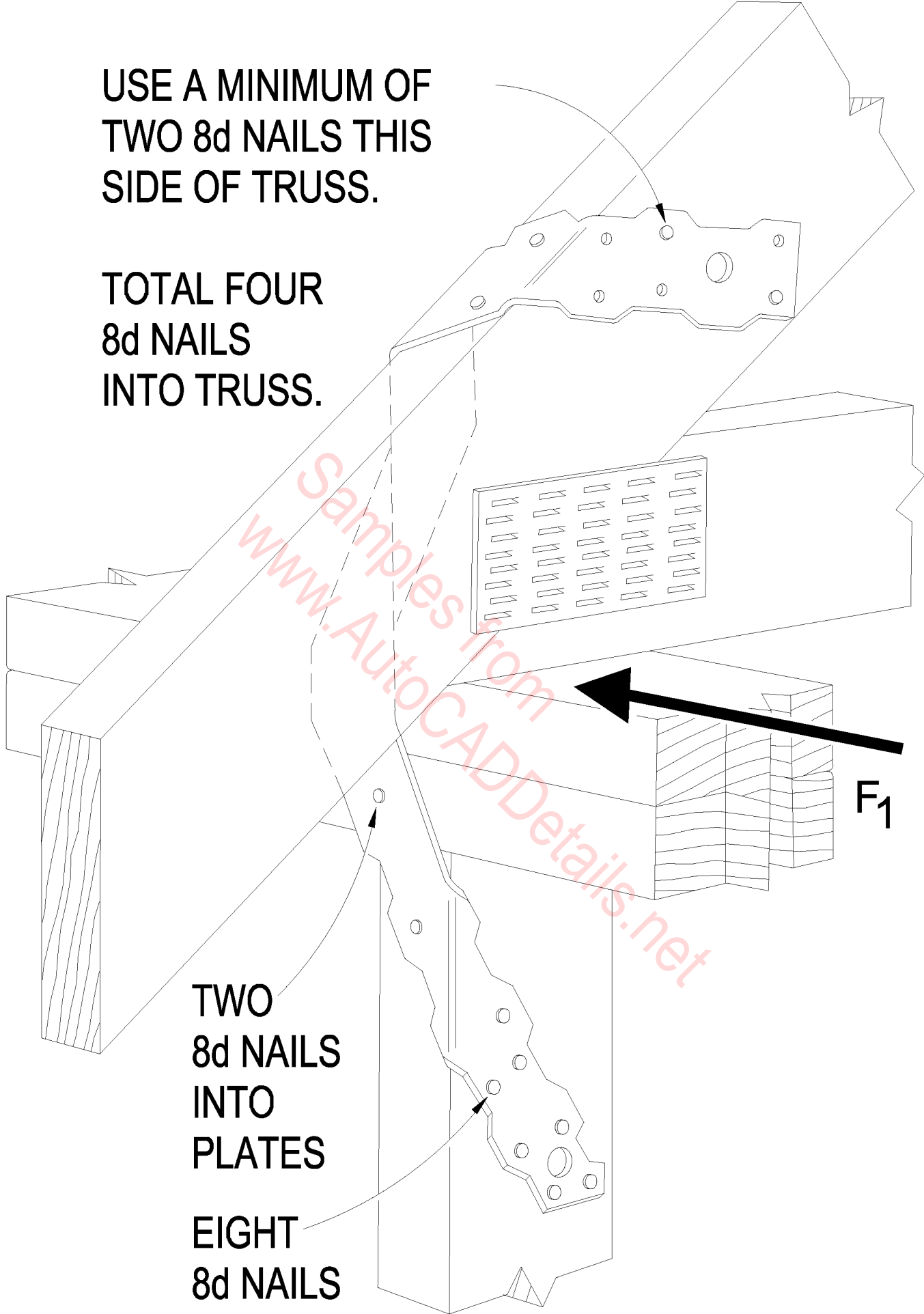

TWO  
8d NAILS  
INTO  
PLATES

EIGHT  
8d NAILS  
INTO  
STUD

Simpson Strong-Tie  
H7

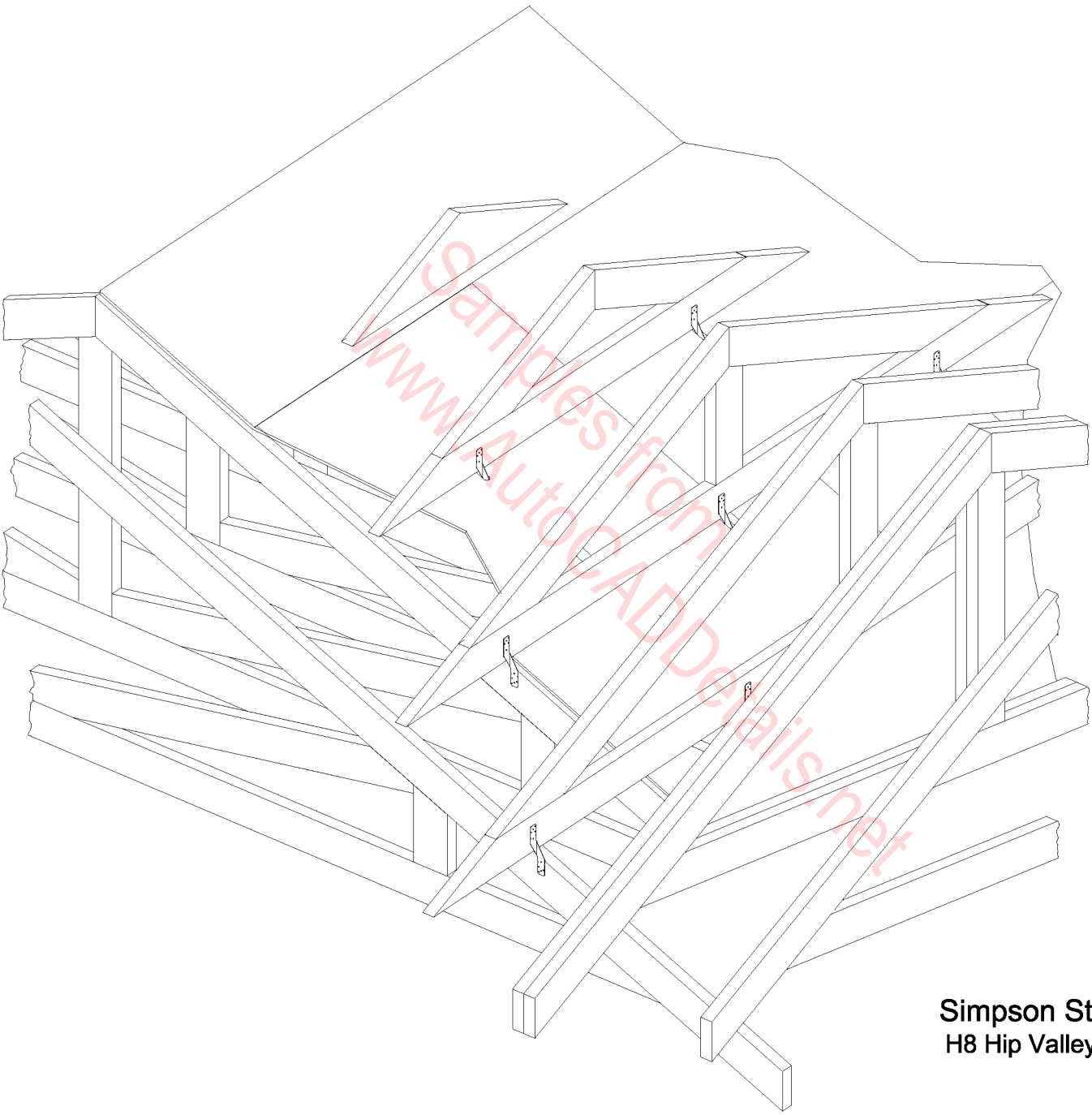

**Simpson Strong-Tie**  
**H8 Hip Valley Truss**



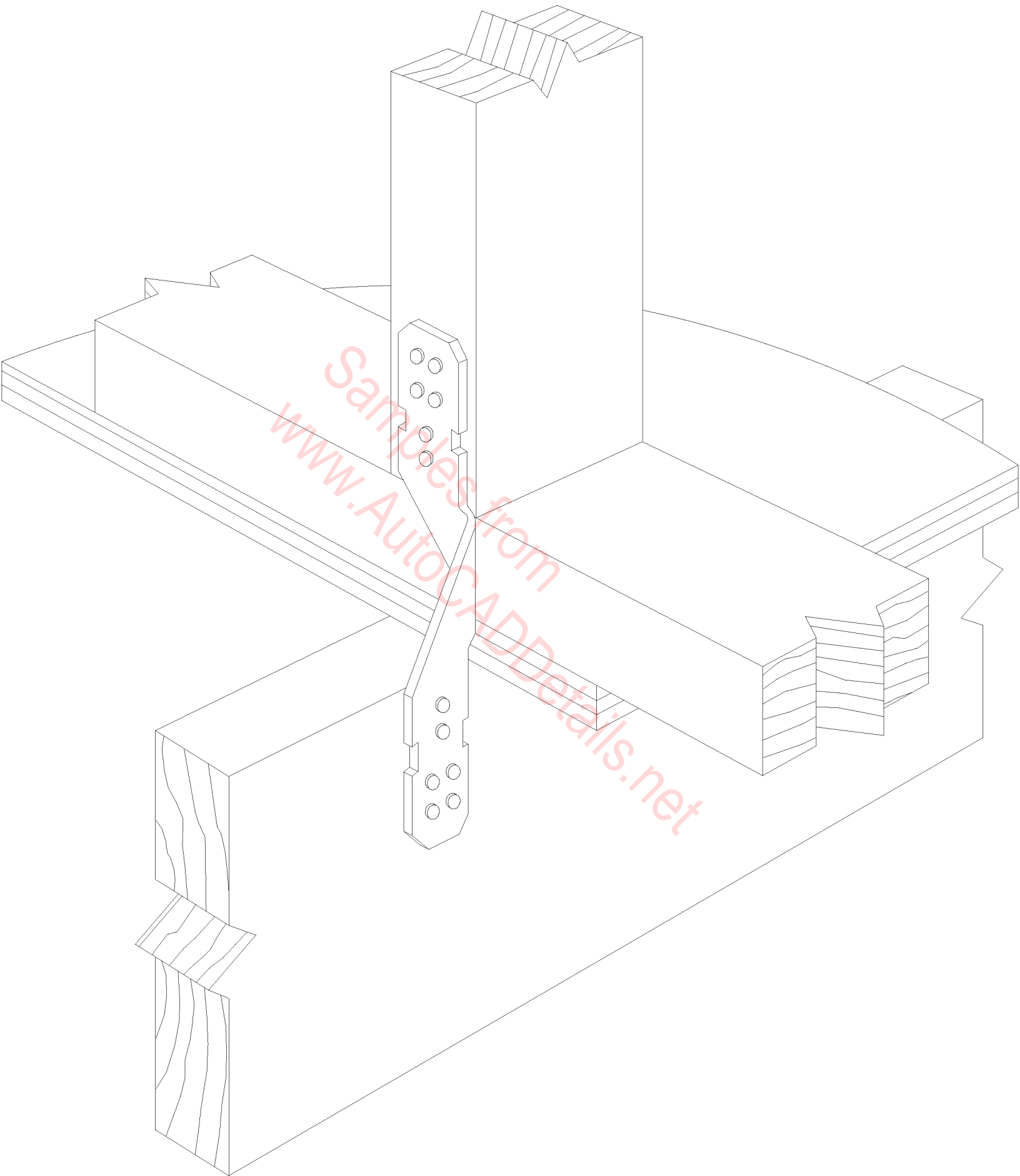

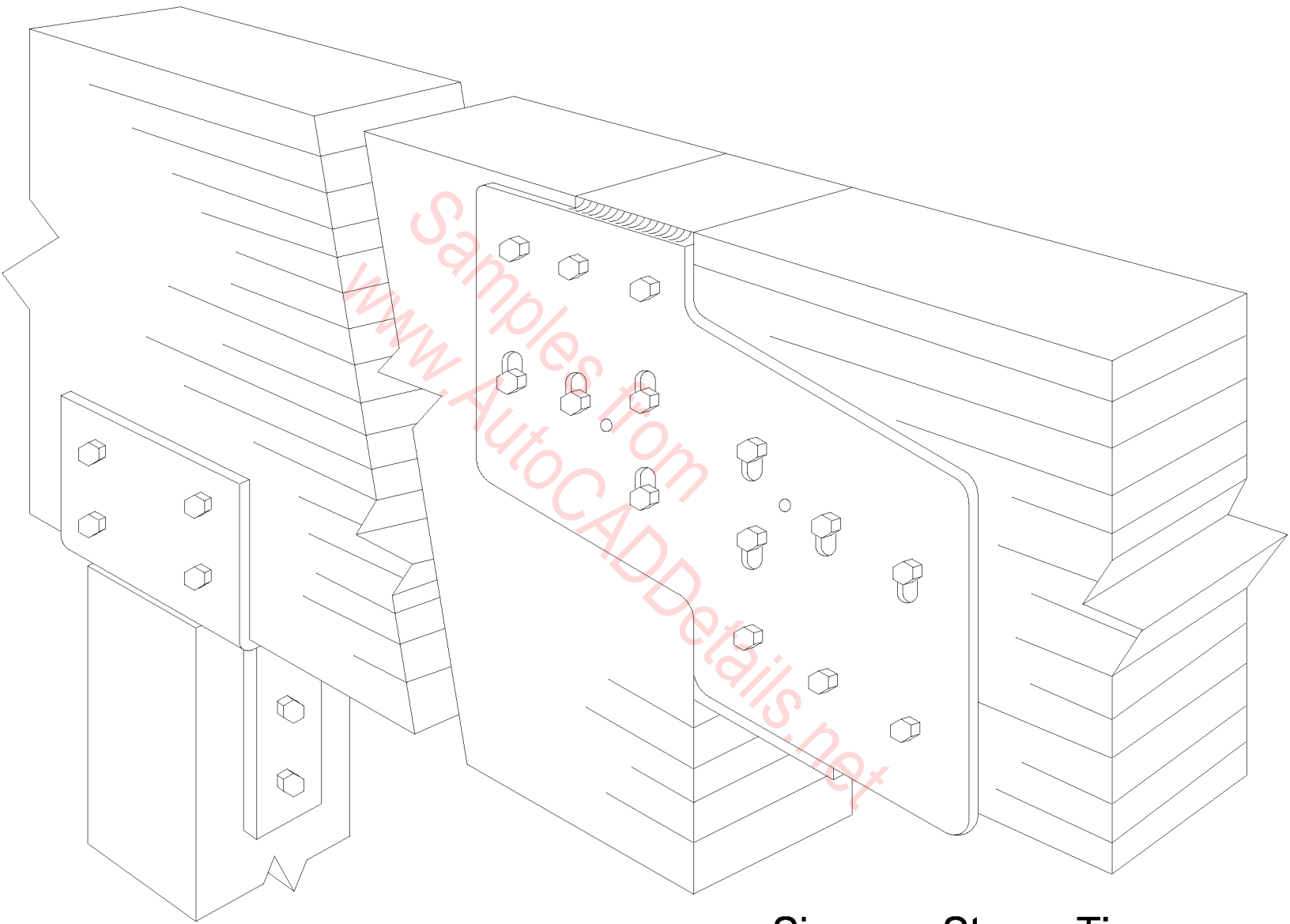

**Simpson Strong-Tie  
HCAC3TA**

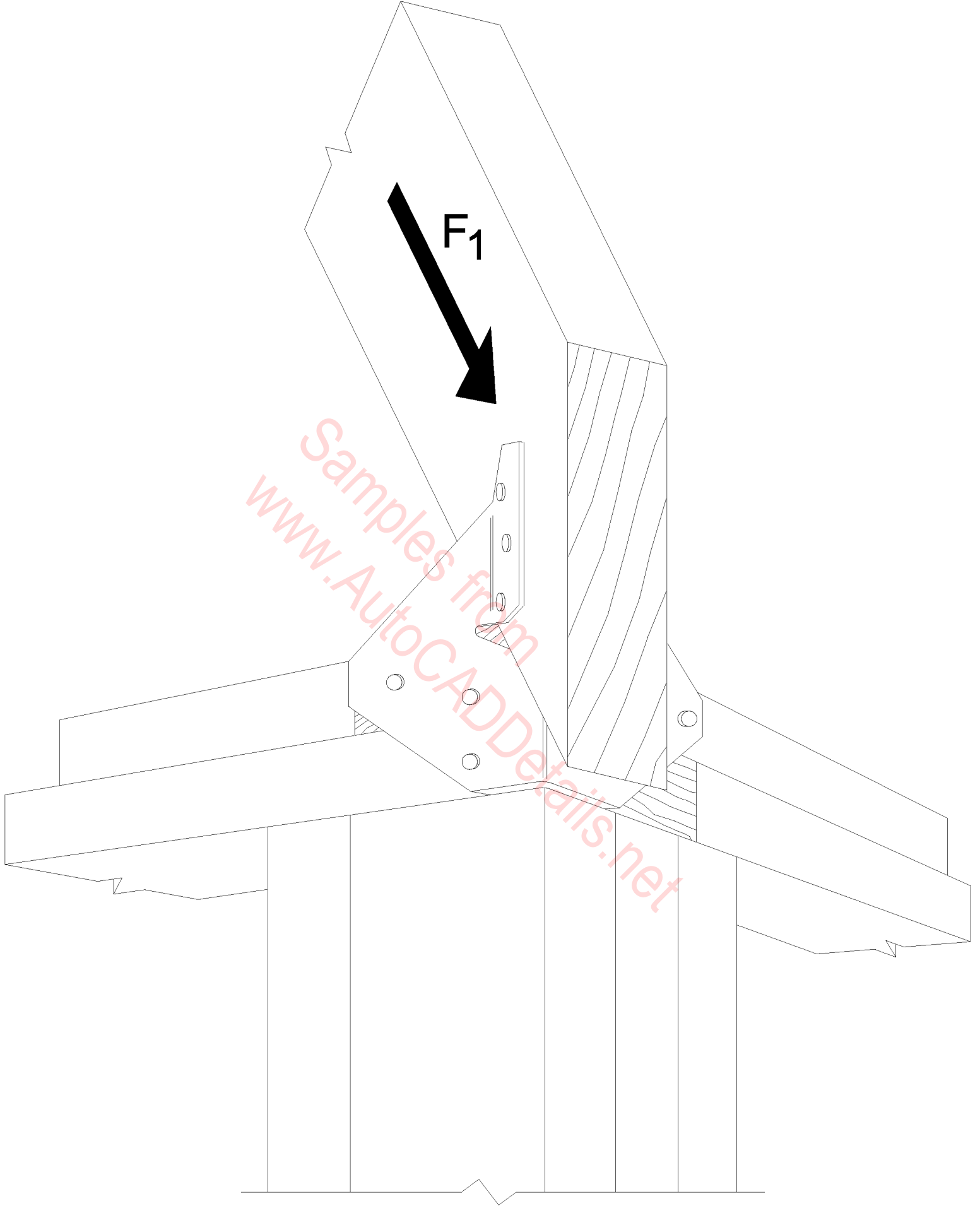

**Simpson Strong-Tie  
HCP**

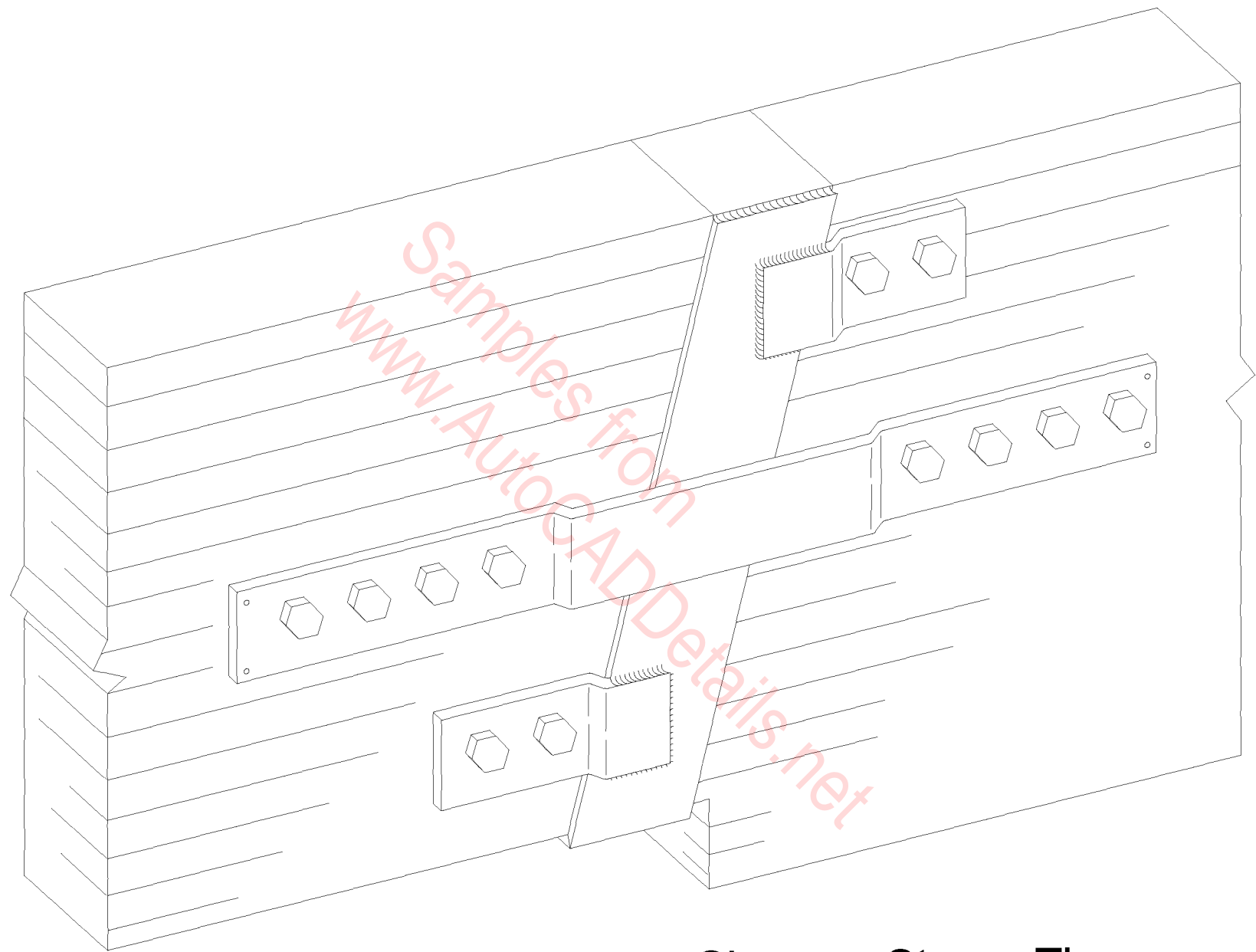

**Simpson Strong-Tie  
HCSTR4**

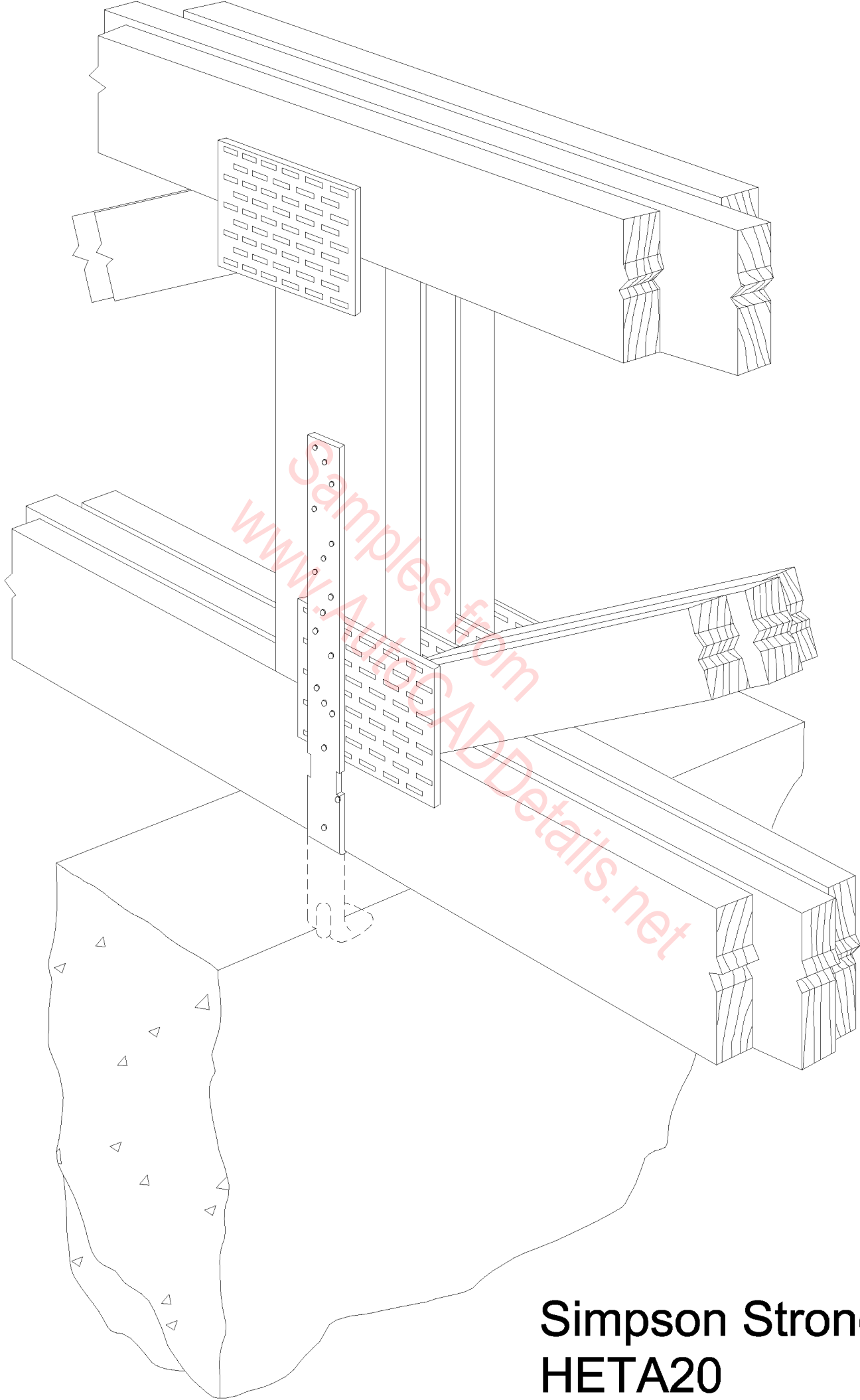

**Simpson Strong-Tie  
HETA20**

Simpson Strong-Tie  
HGA10

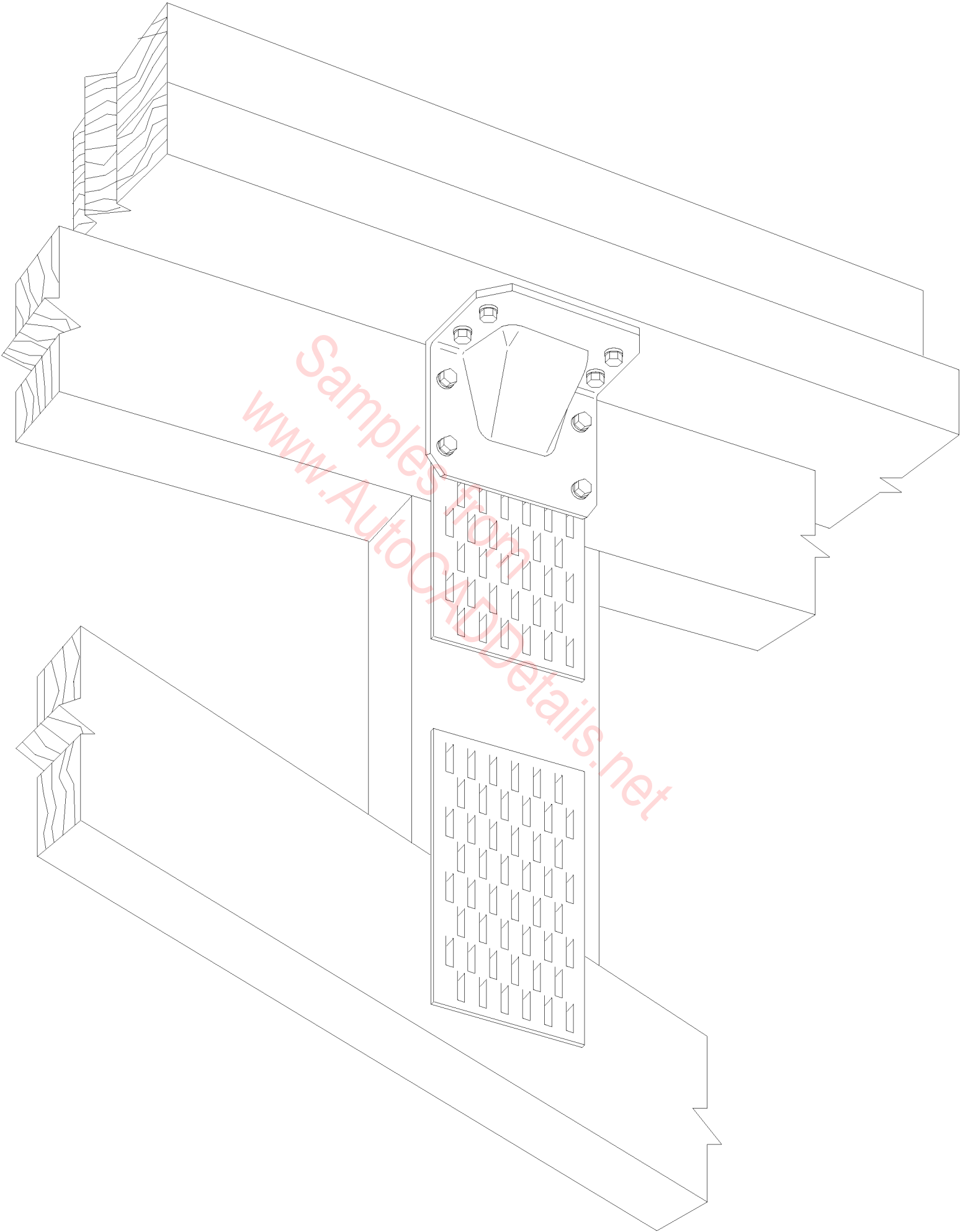

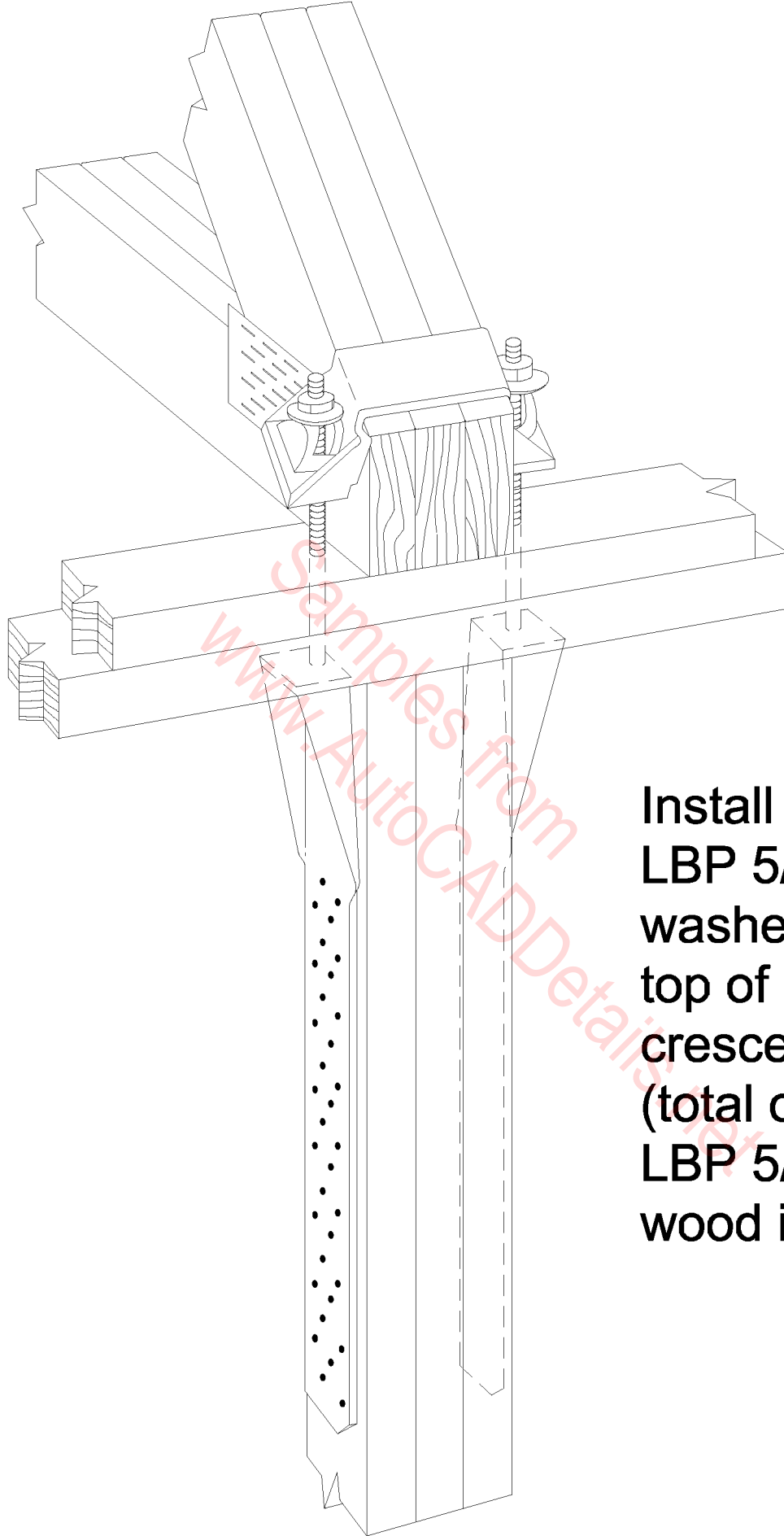

Install two  
LBP 5/8  
washers on  
top of each  
crescent washer  
(total of four  
LBP 5/8's) for  
wood installation

Simpson Strong-Tie  
HGT-3 with HTT22s

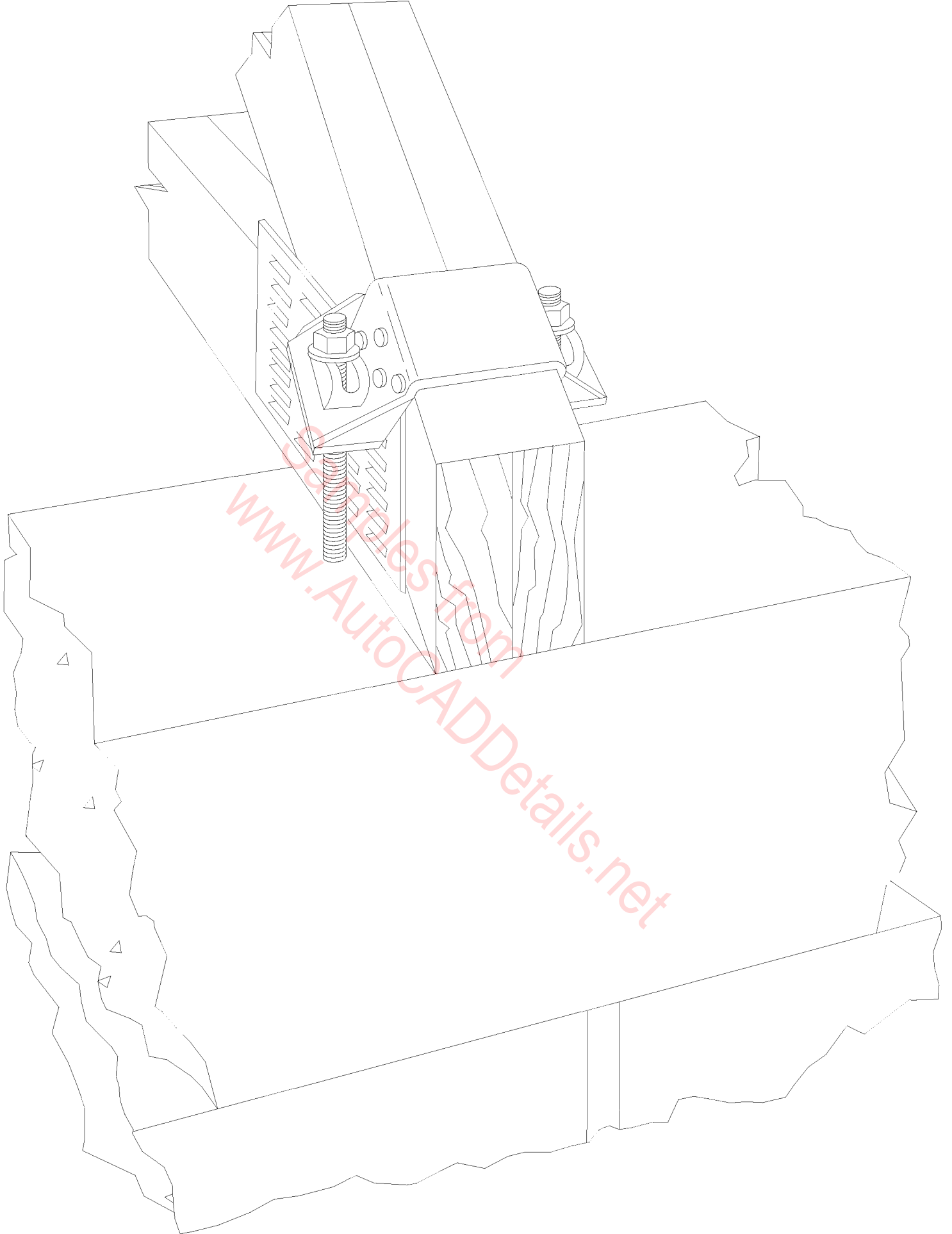

**Simpson Strong-Tie  
HGT-2**



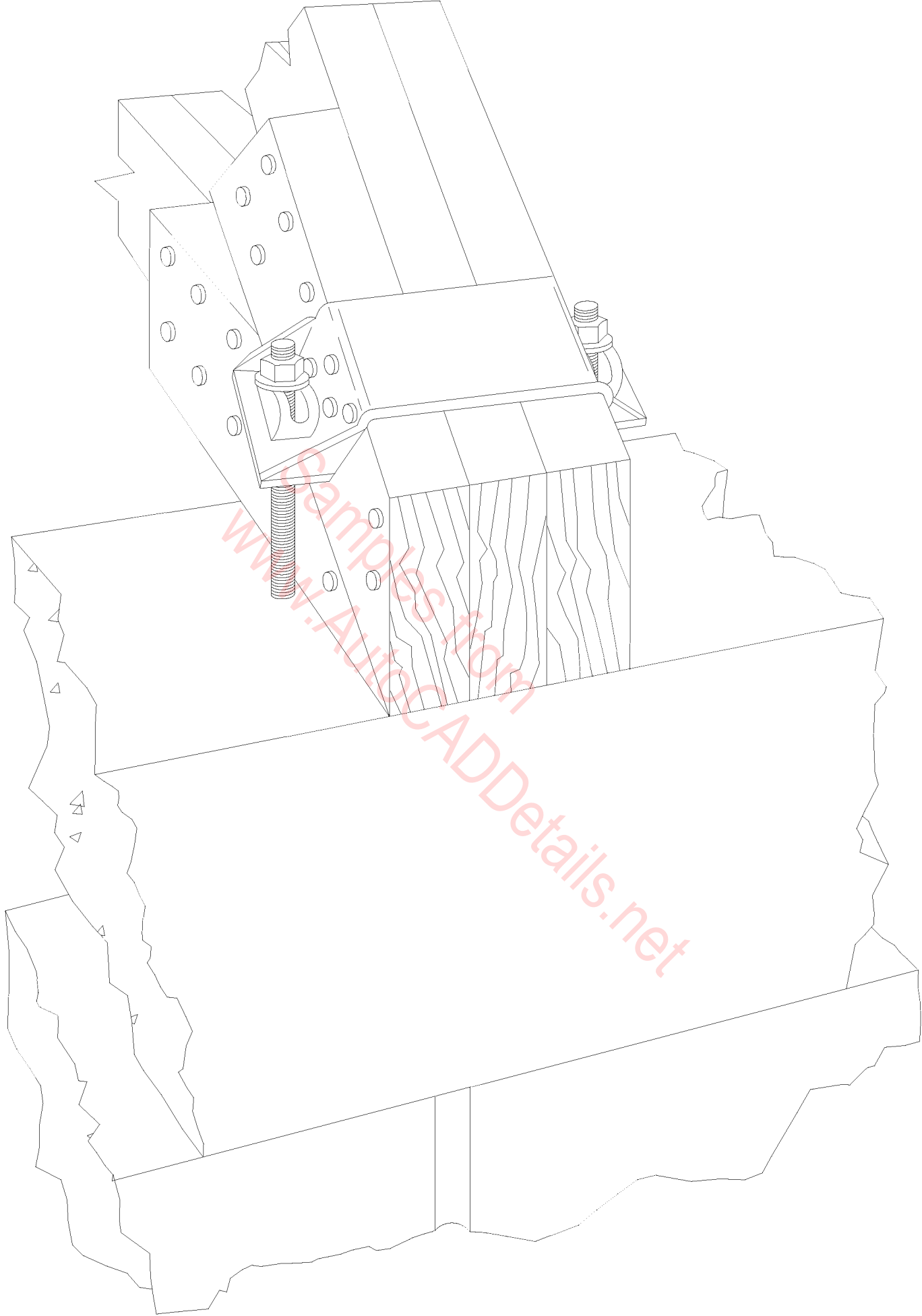

**Simpson Strong-Tie  
HGT-3**

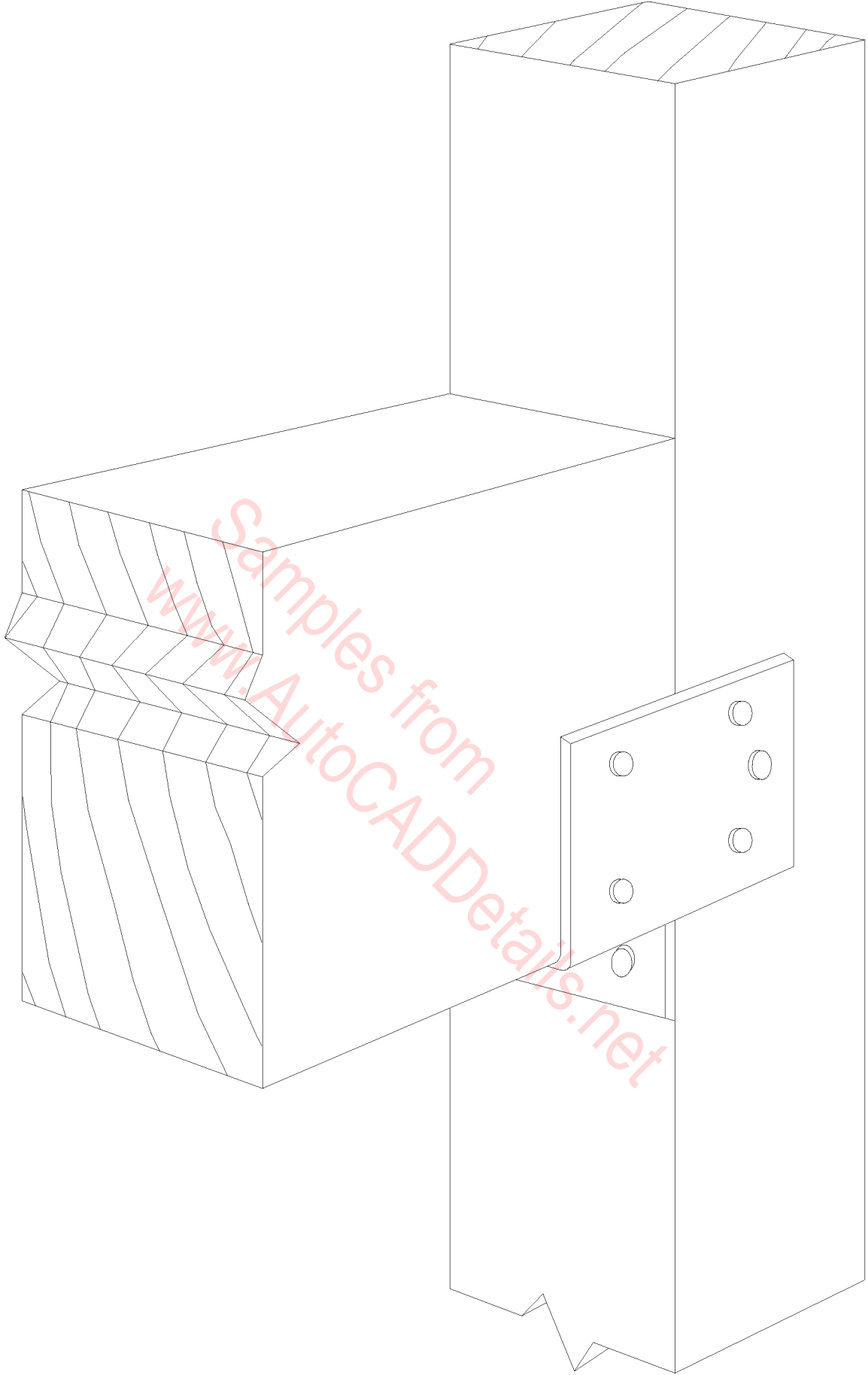

**Simpson Strong-Tie  
HH**

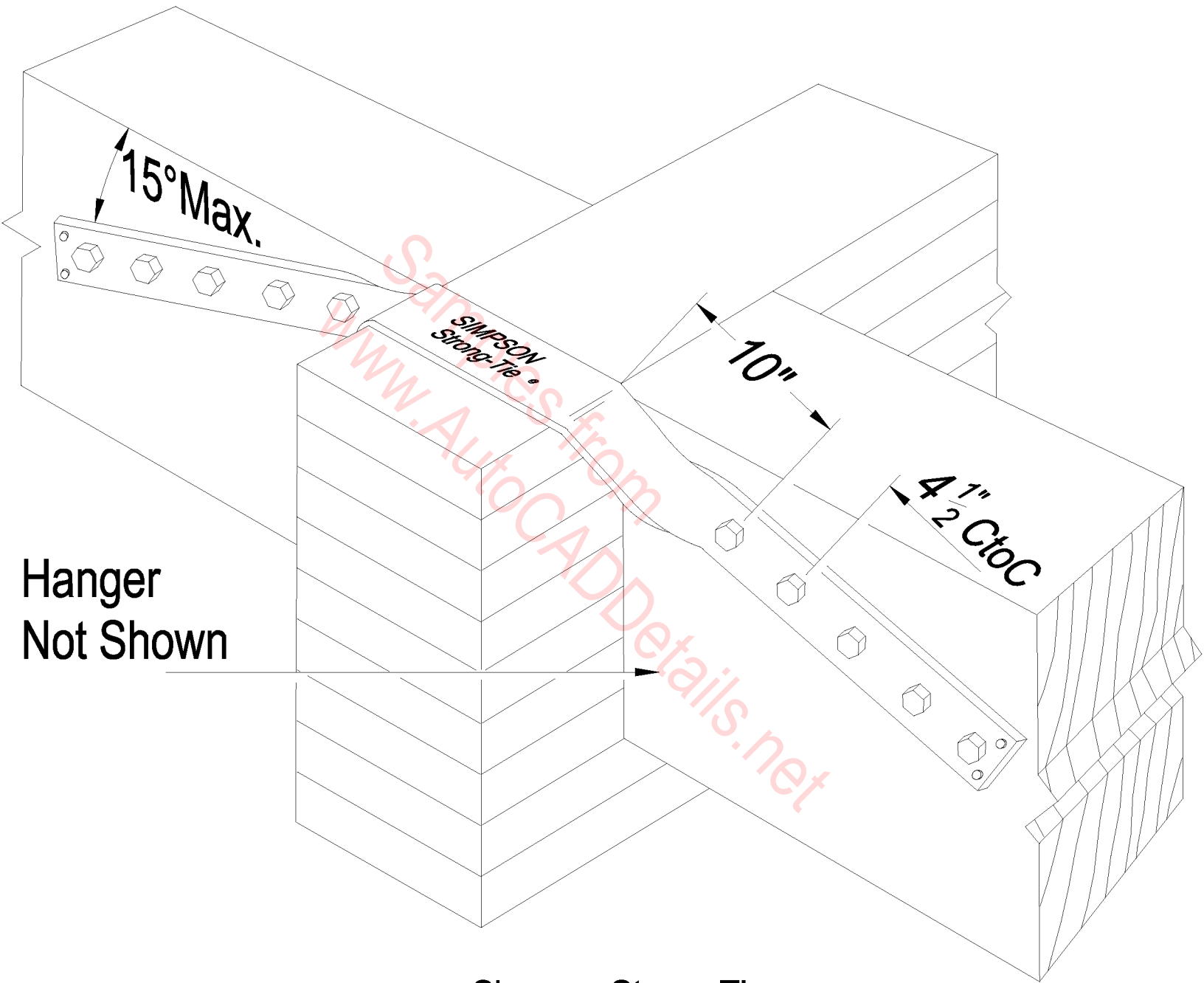

Simpson Strong-Tie  
HSA

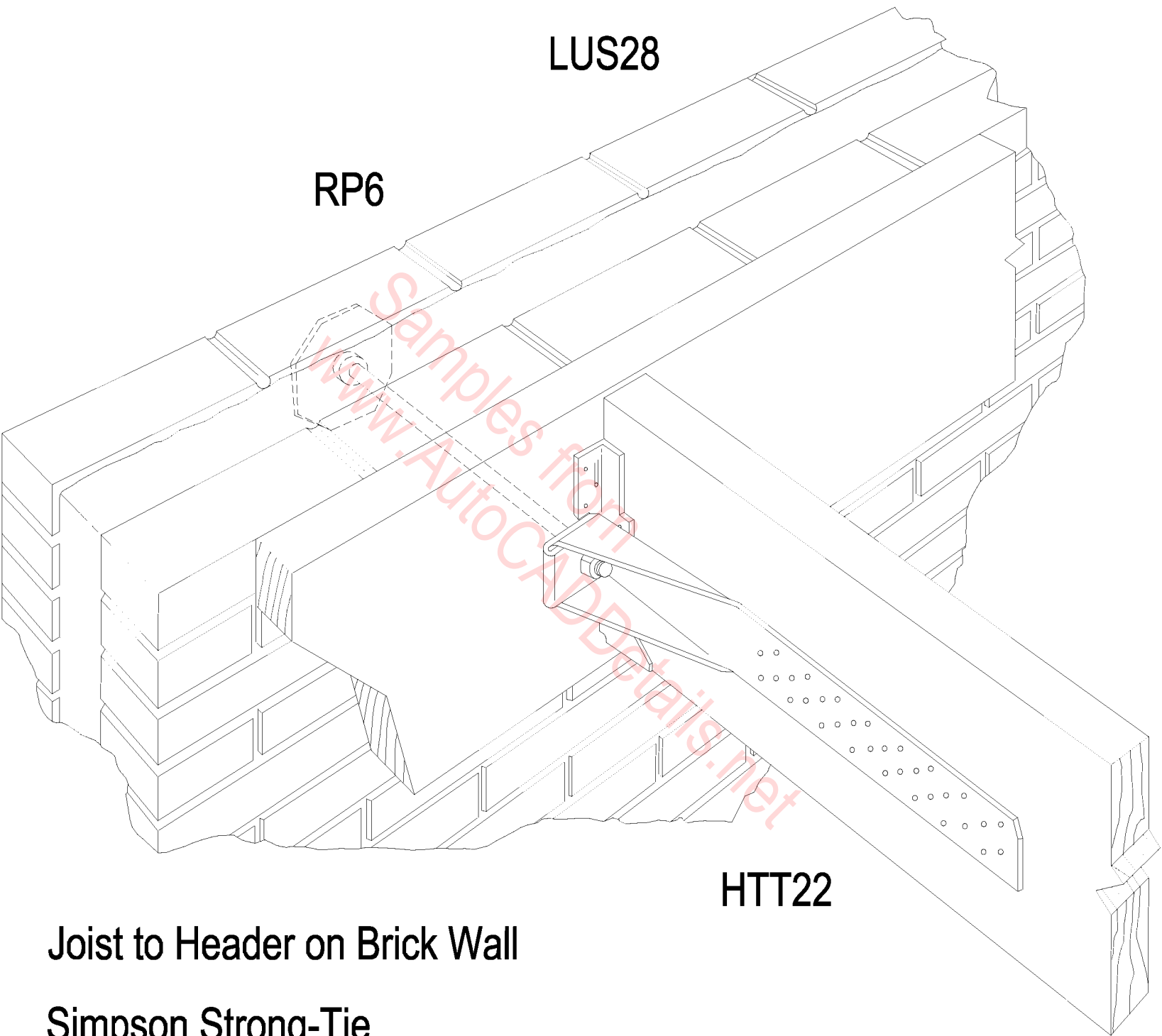

**Joist to Header on Brick Wall**

**Simpson Strong-Tie  
HTT22 with LUS28 and RP6**

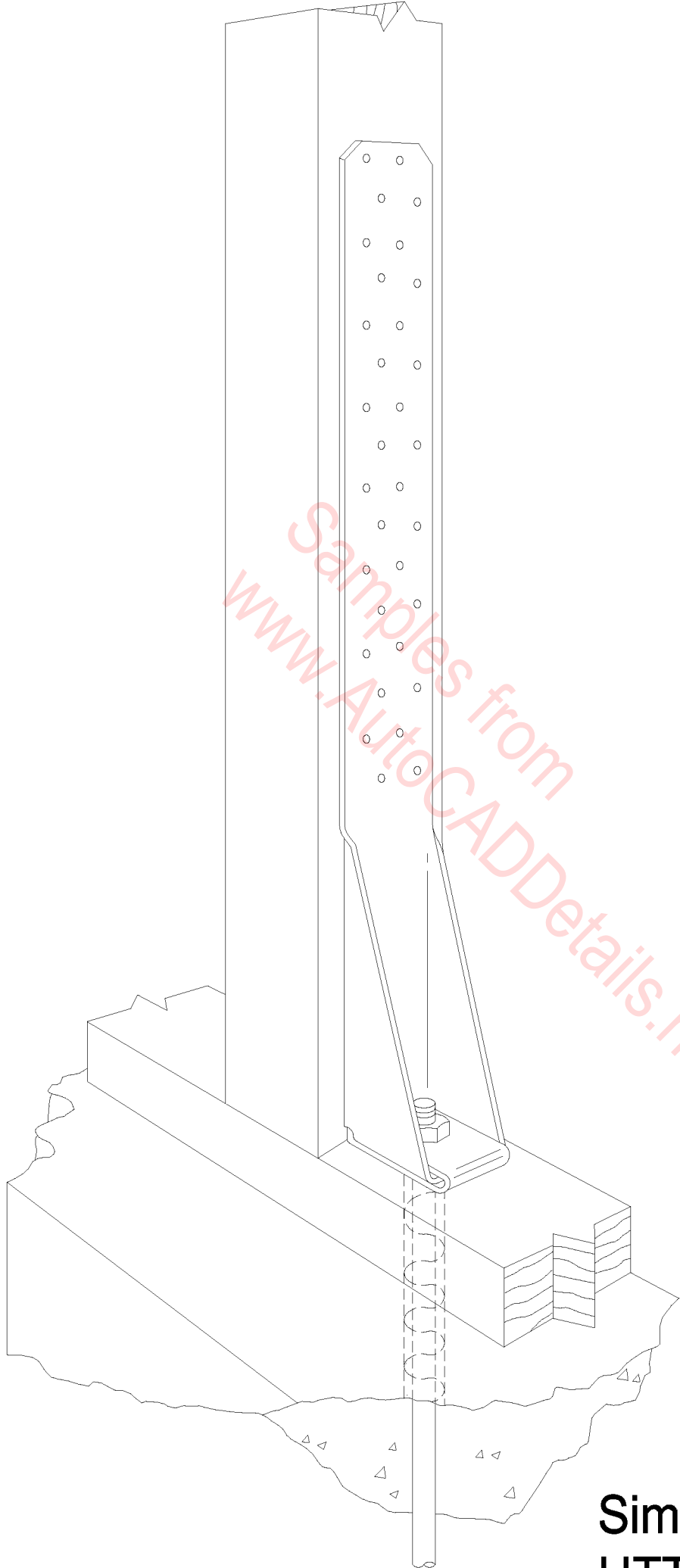

Samples from  
[www.AutoCADDetails.net](http://www.AutoCADDetails.net)

**Simpson Strong-Tie  
HTT22**

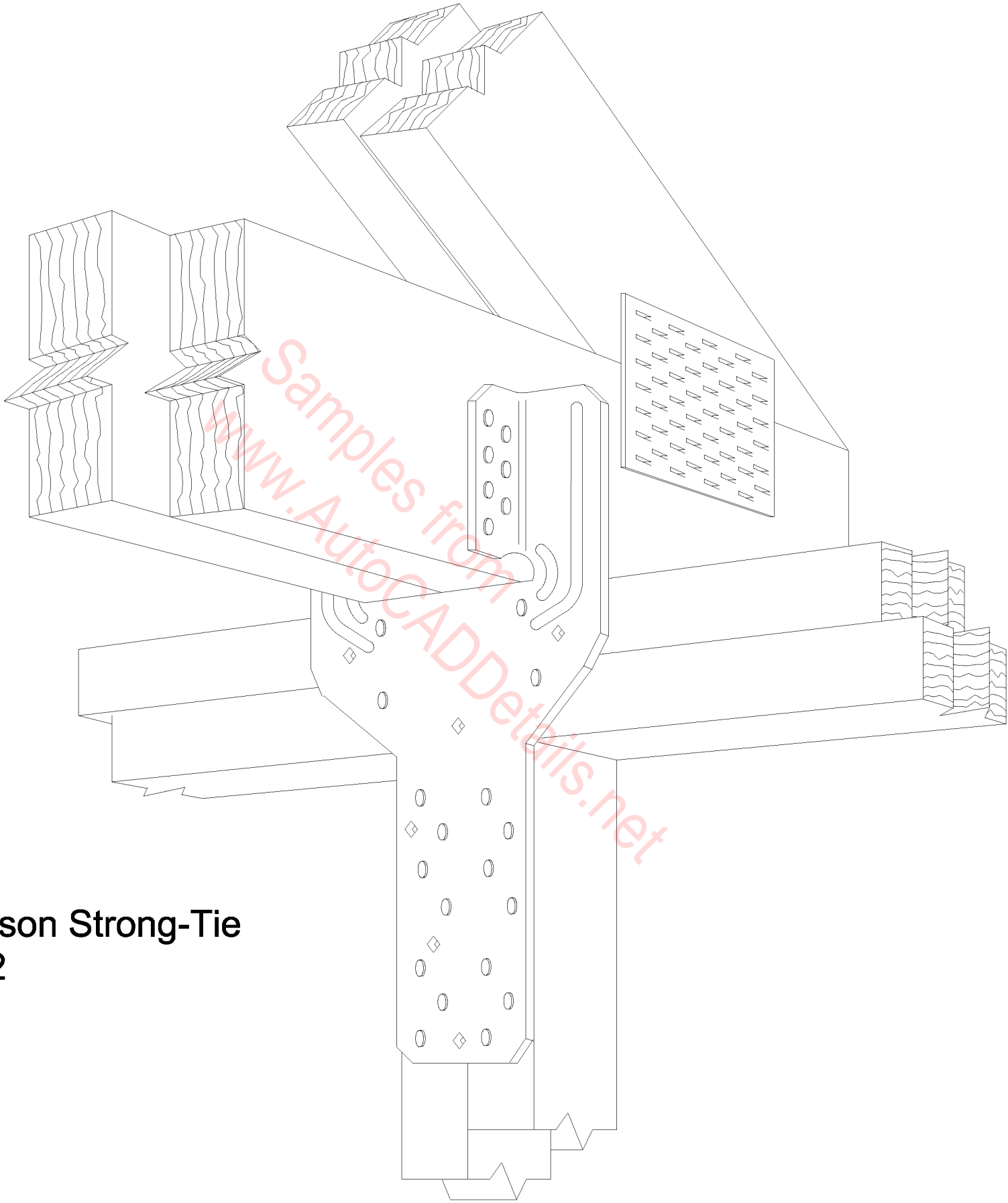

**Simpson Strong-Tie  
LGT2**

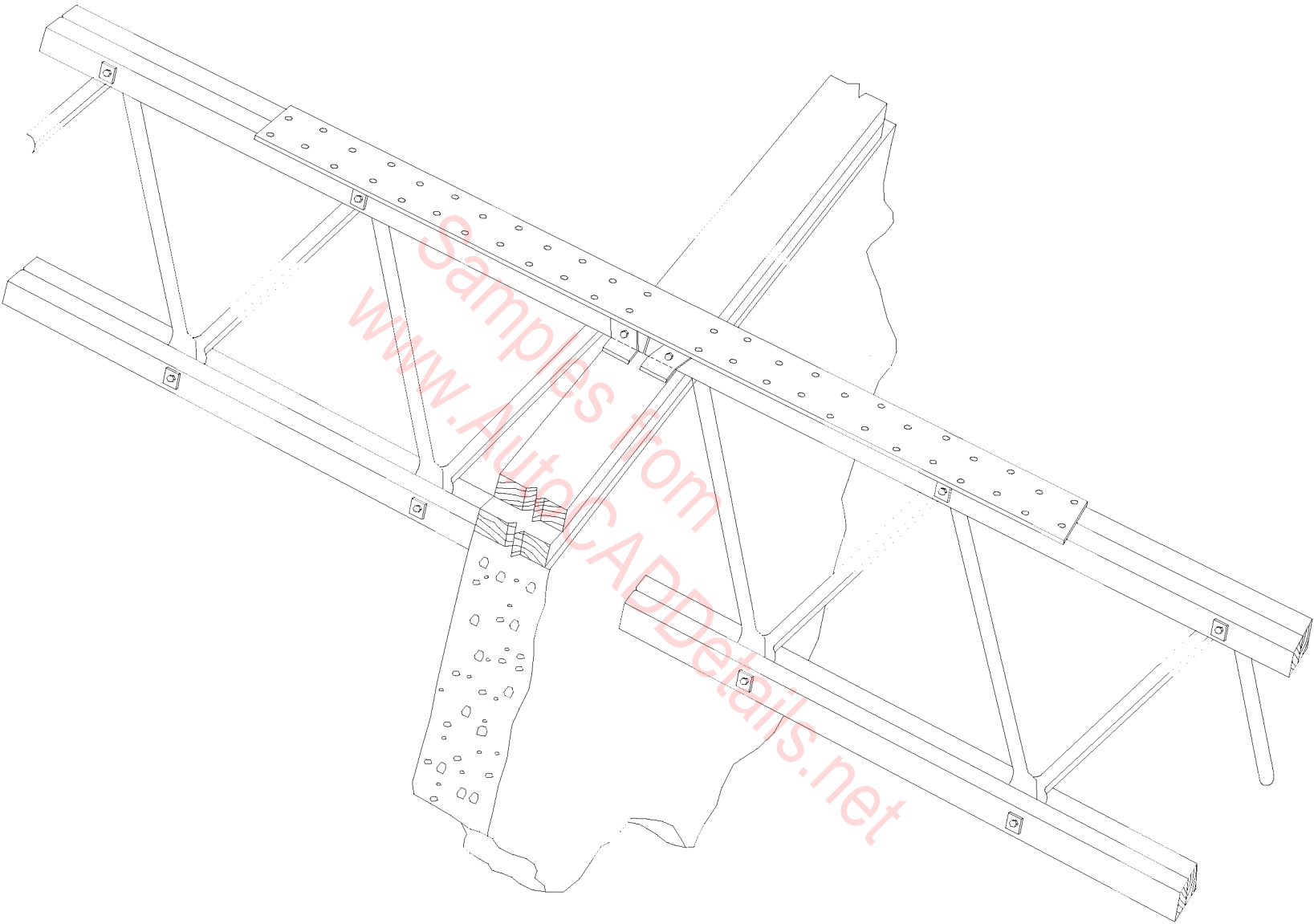

**Simpson Strong-Tie  
LSTI**

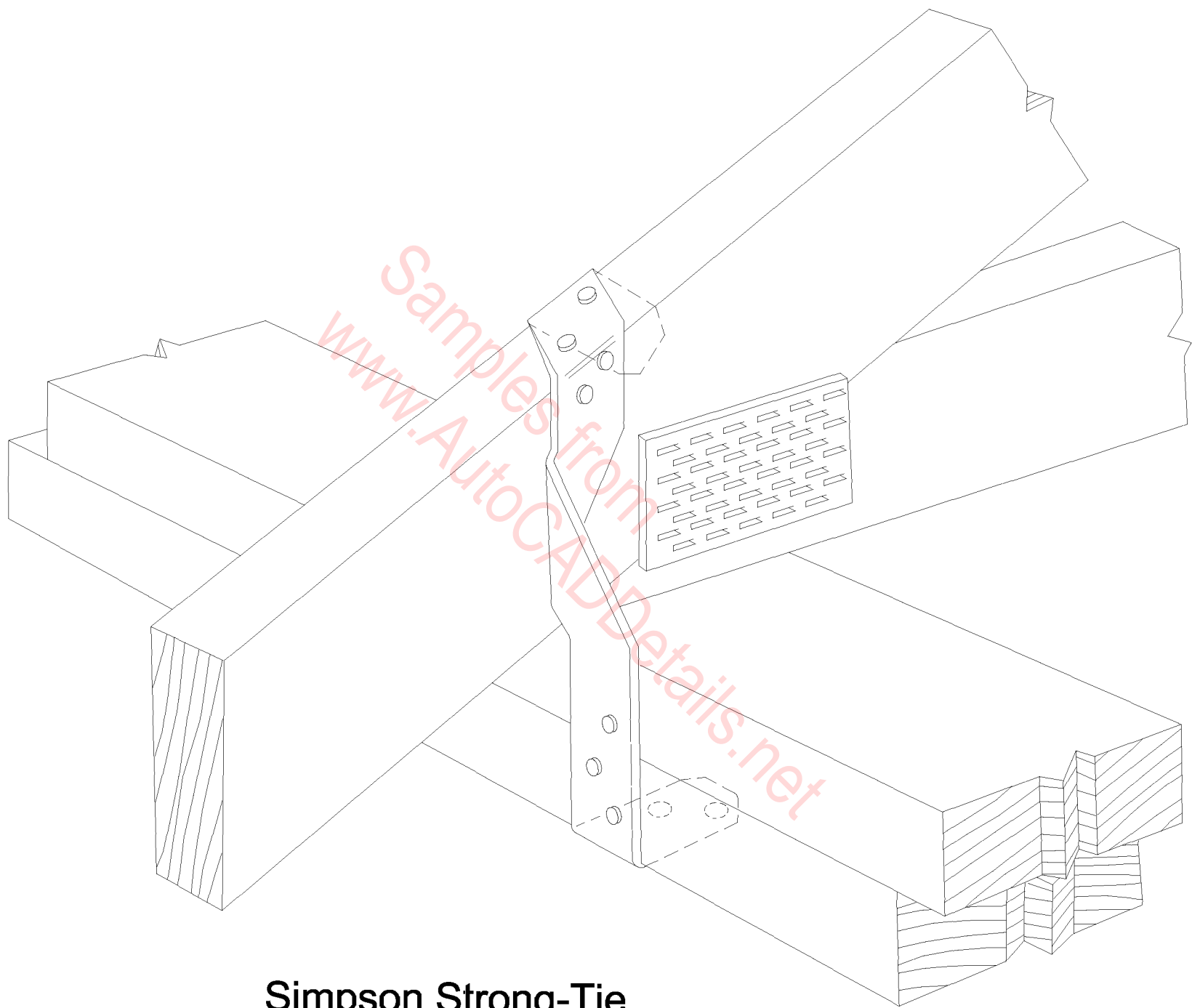

**Simpson Strong-Tie  
LTS**



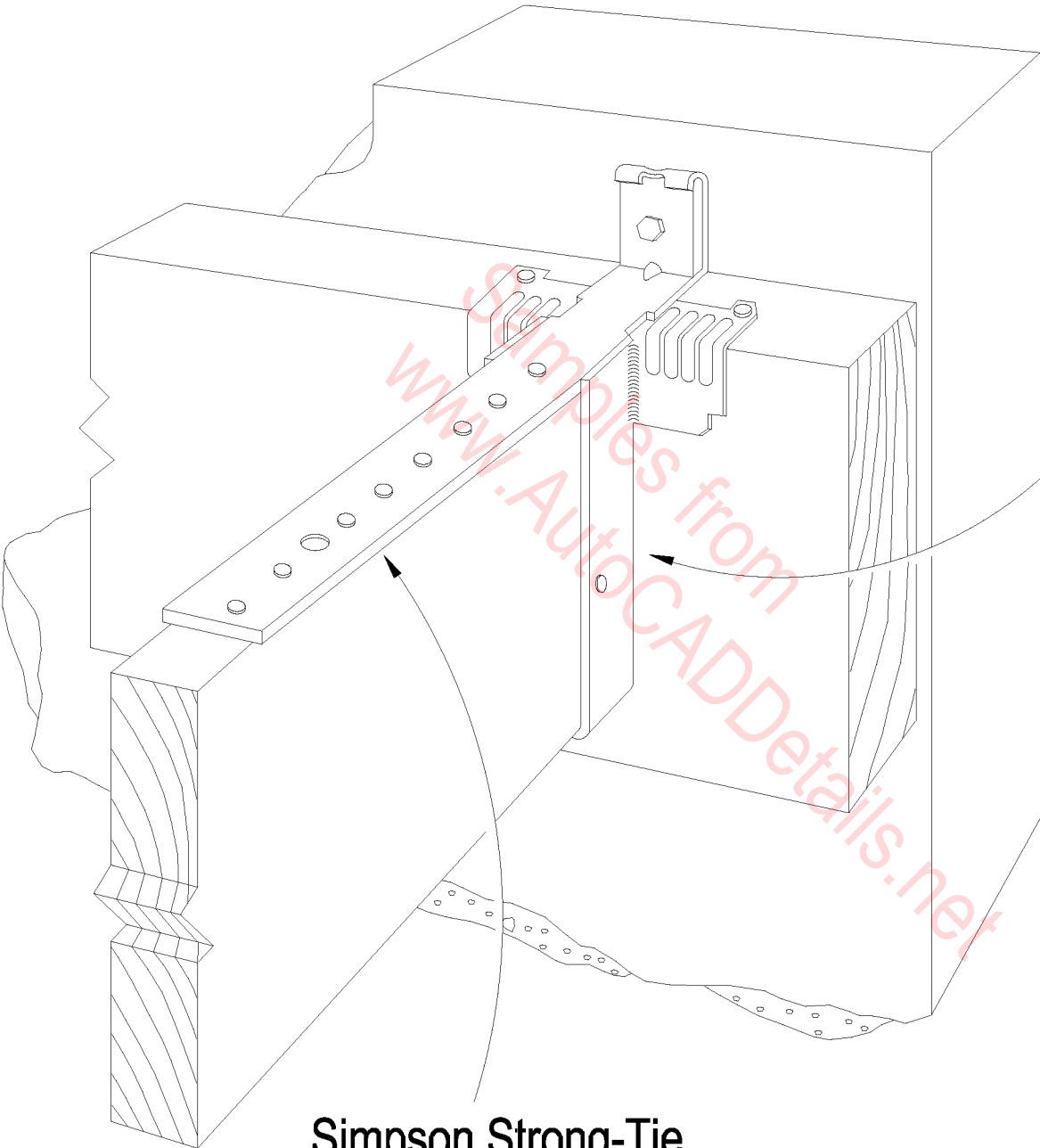

Simpson Strong-Tie  
W

Simpson Strong-Tie  
LTT19

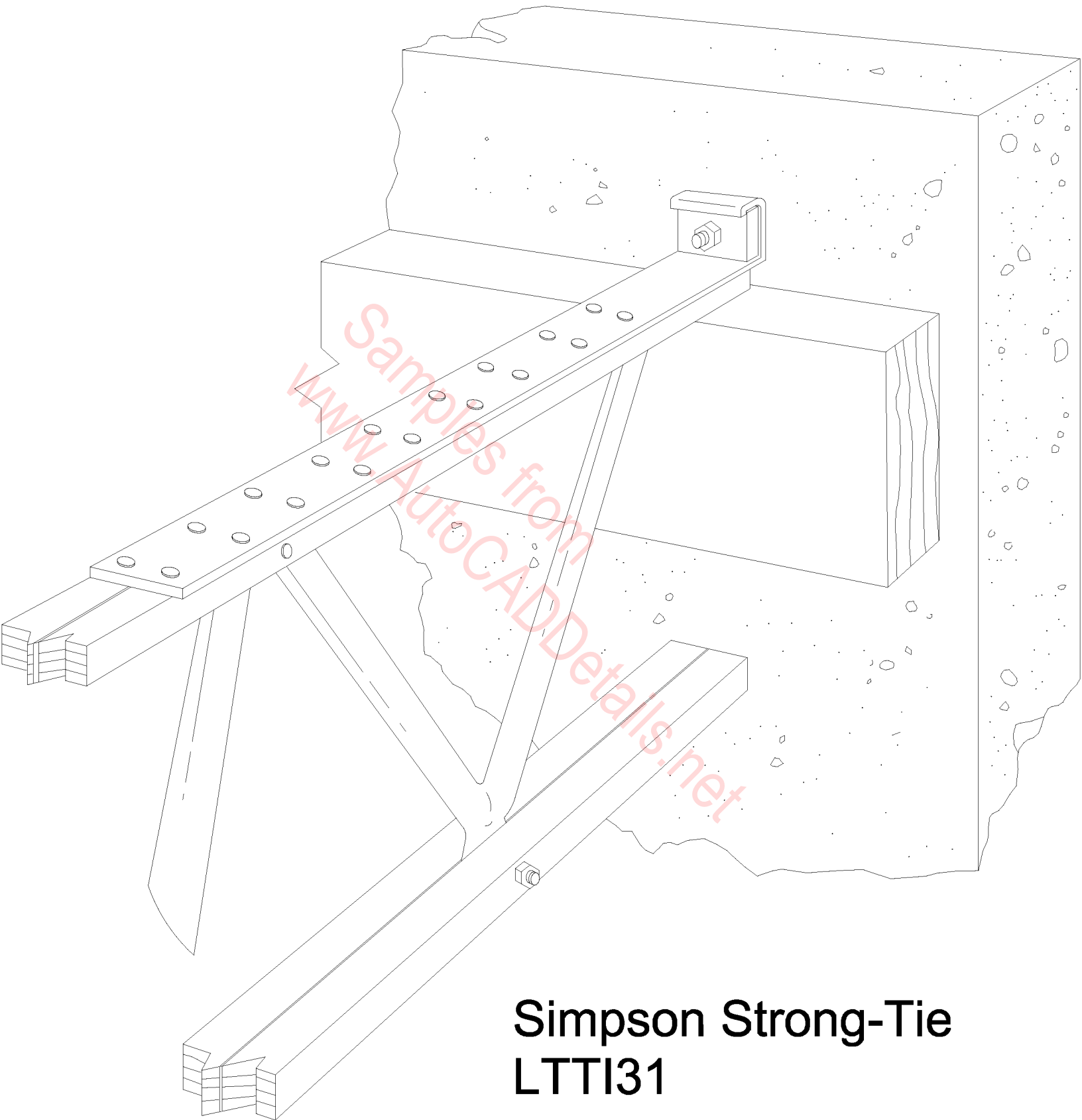

**Simpson Strong-Tie  
LTTI31**

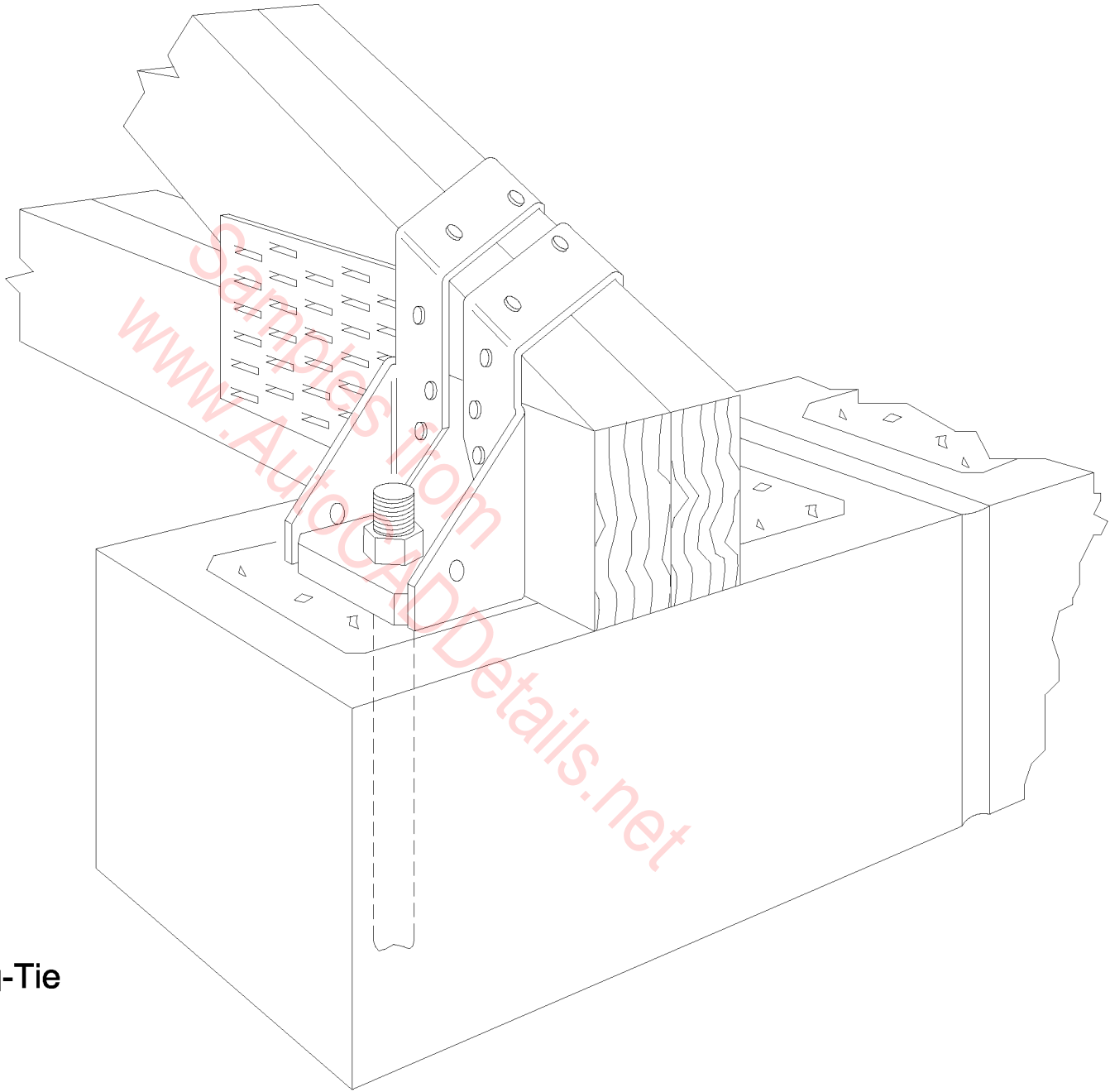

Simpson Strong-Tie  
MGT

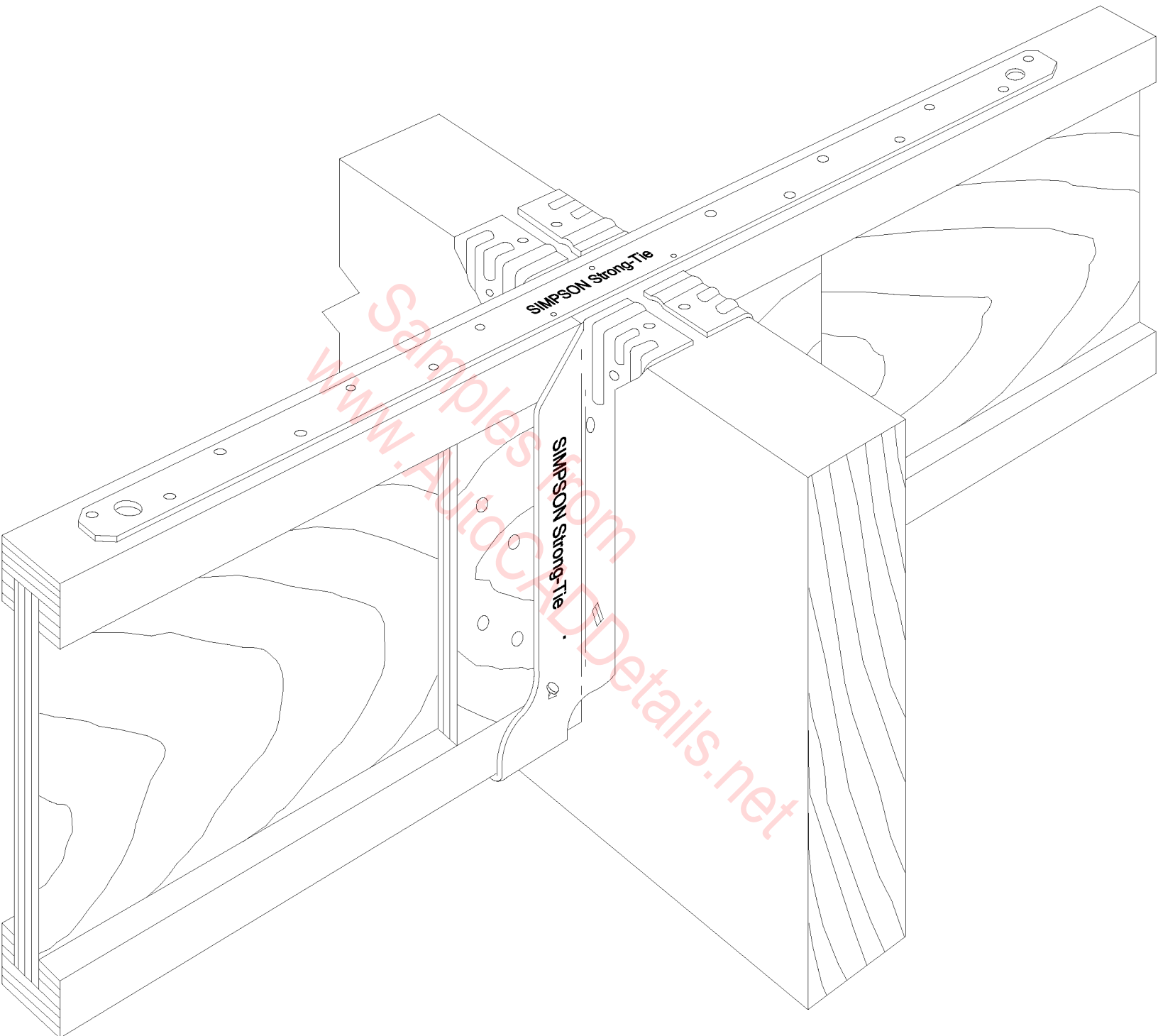

**Simpson Strong-Tie  
MSTI**

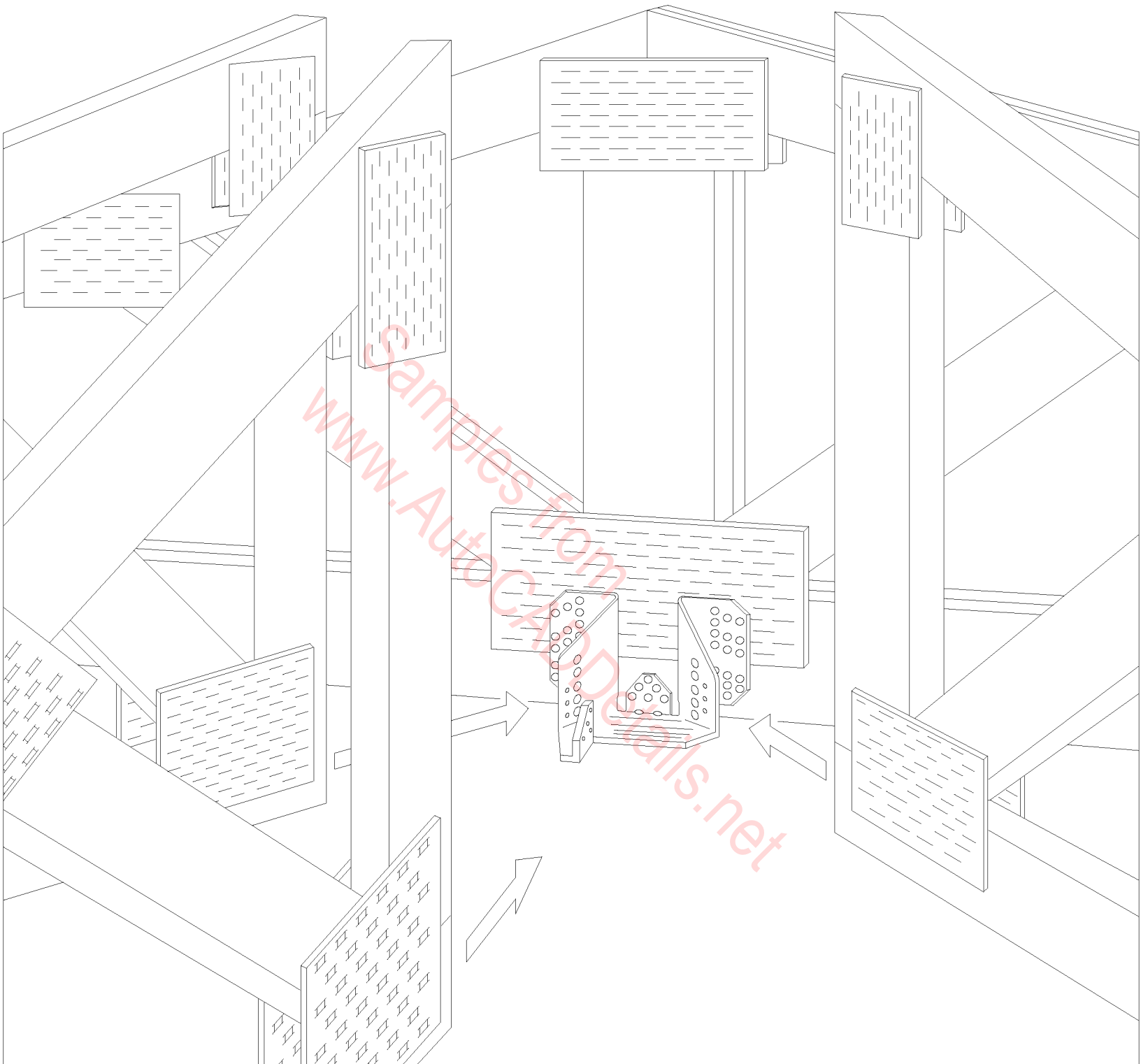

**Simpson Strong-Tie  
MTHM**

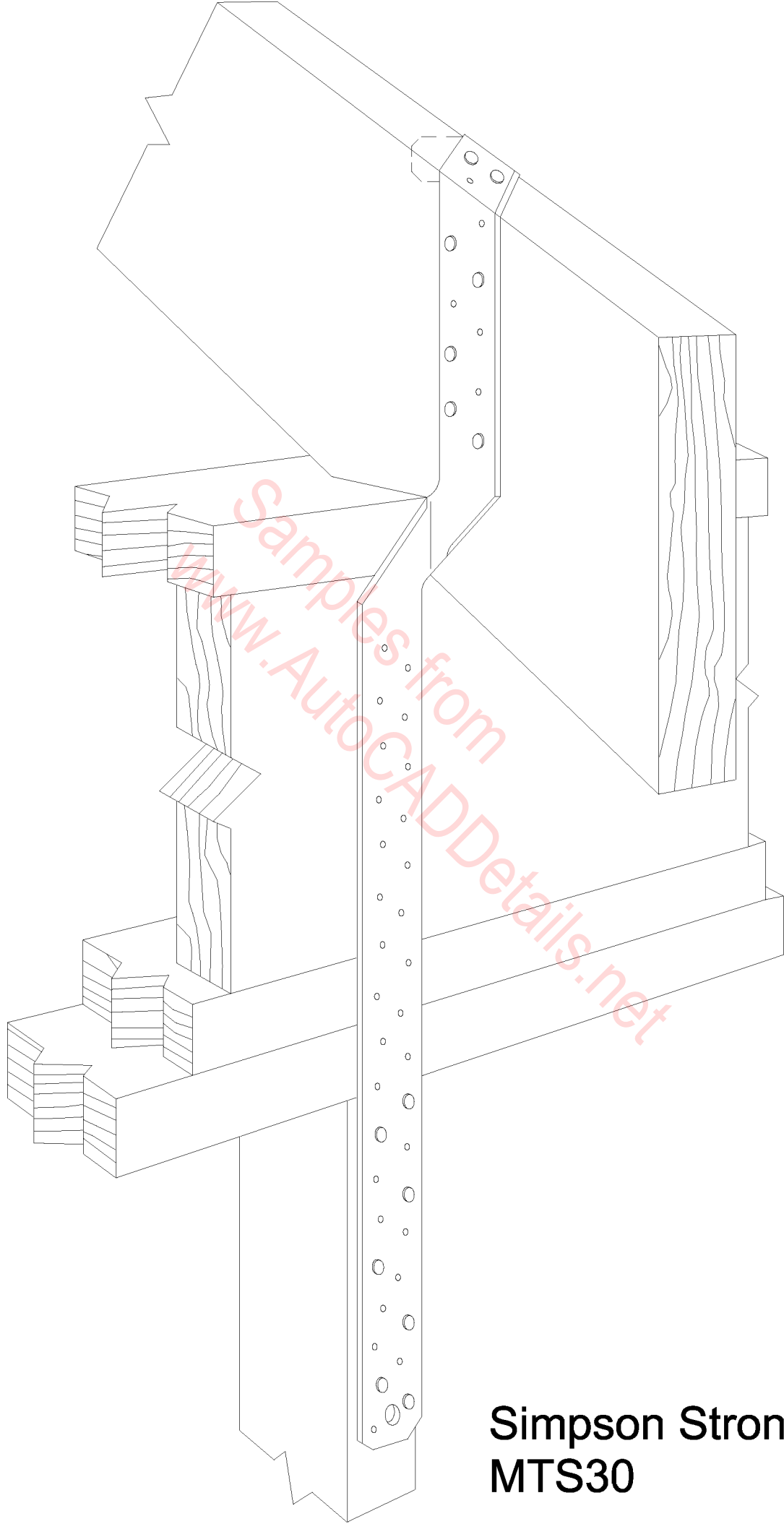

**Simpson Strong-Tie  
MTS30**

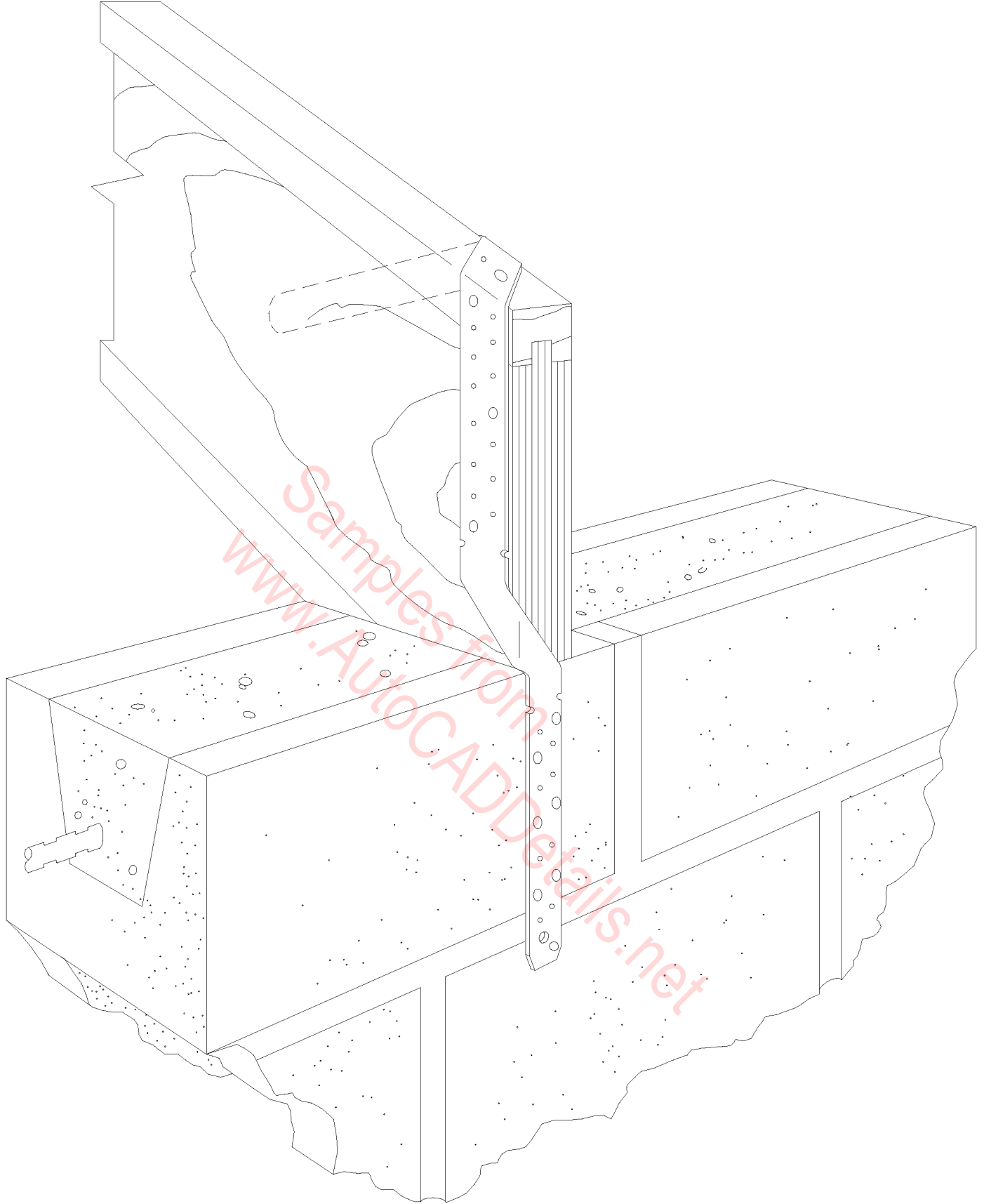

**MTS30 fastened directly to  
bond beam**

**Simpson Strong-Tie  
MTS30**

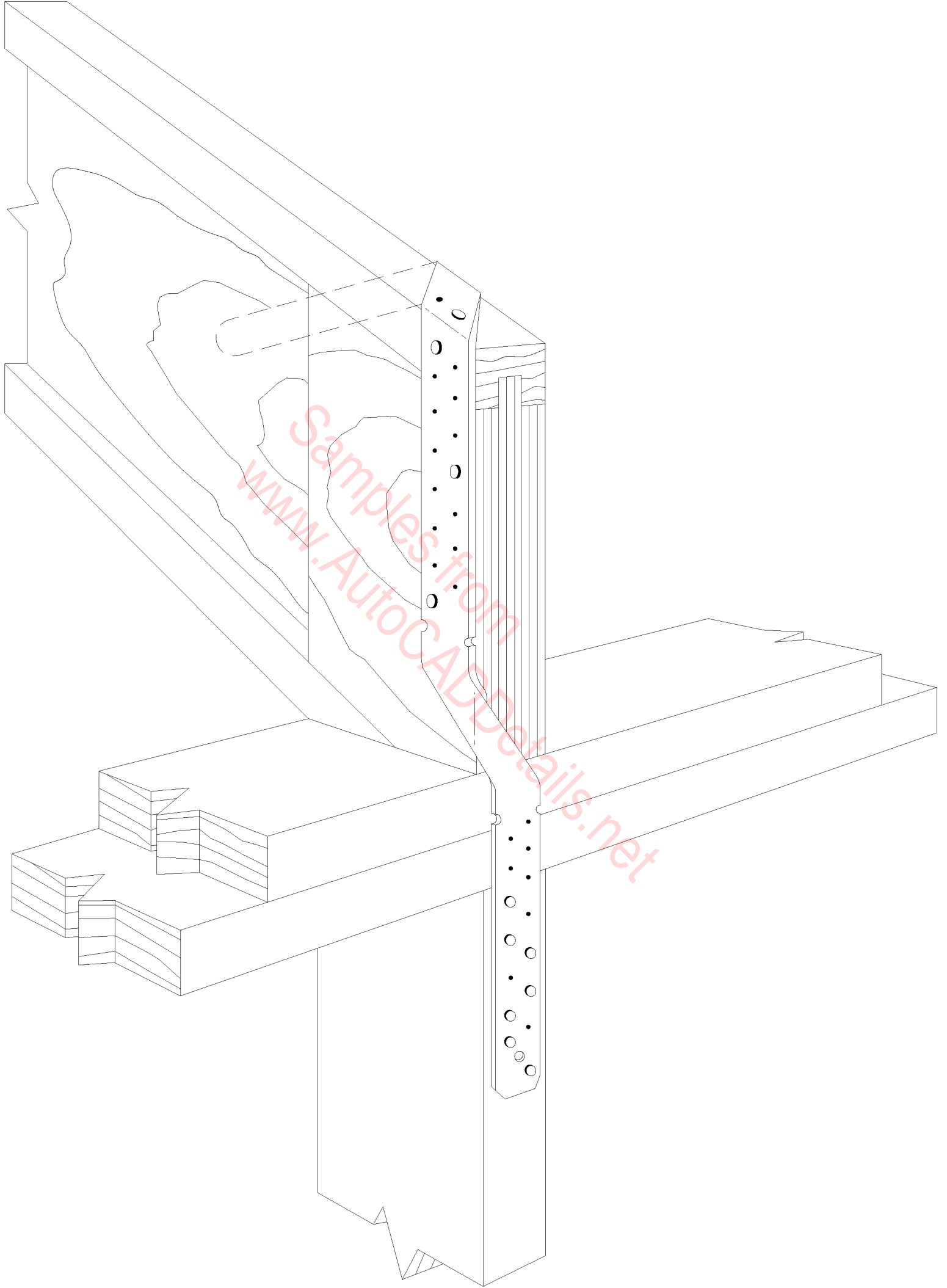



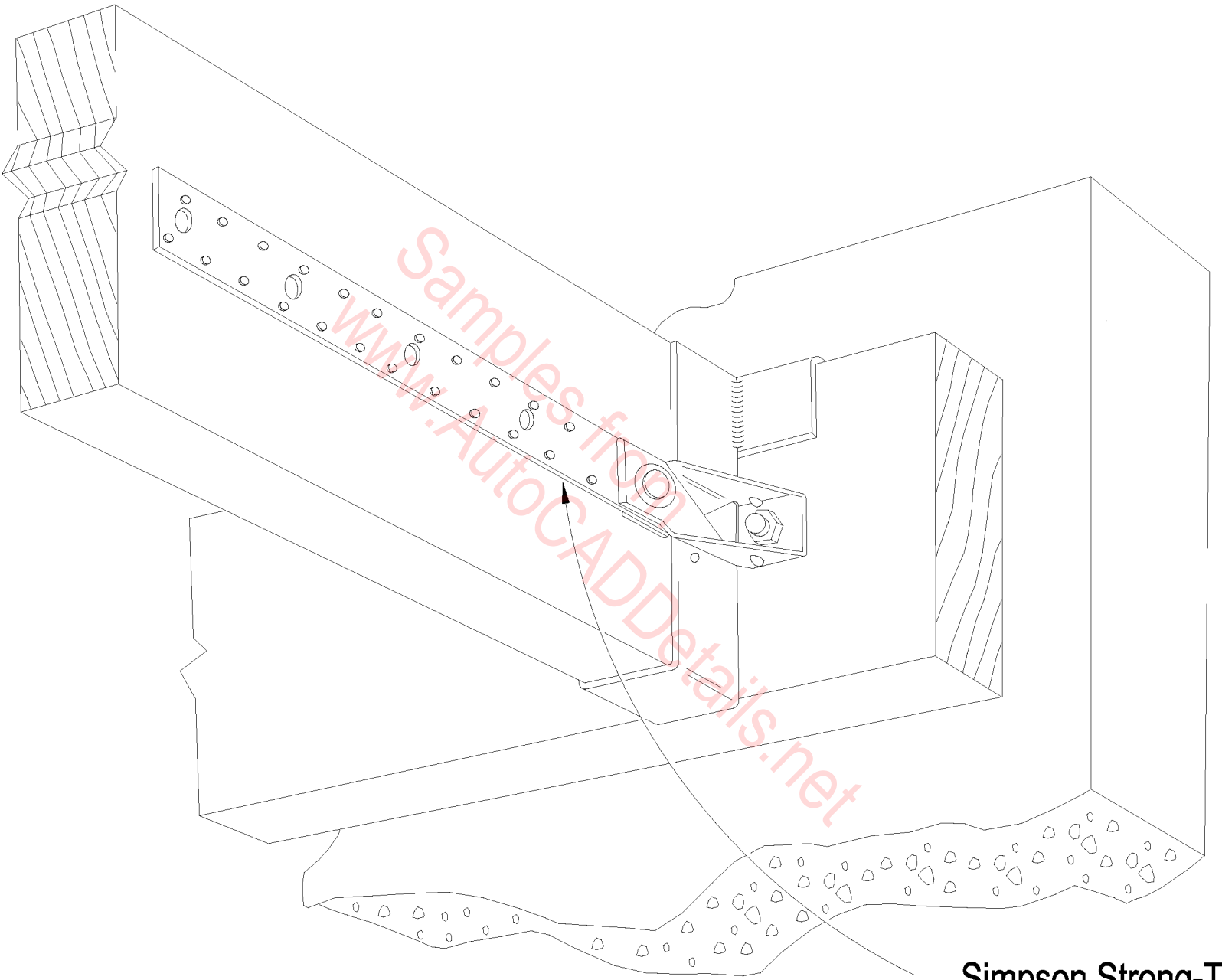

**Simpson Strong-Tie  
MTT28B**

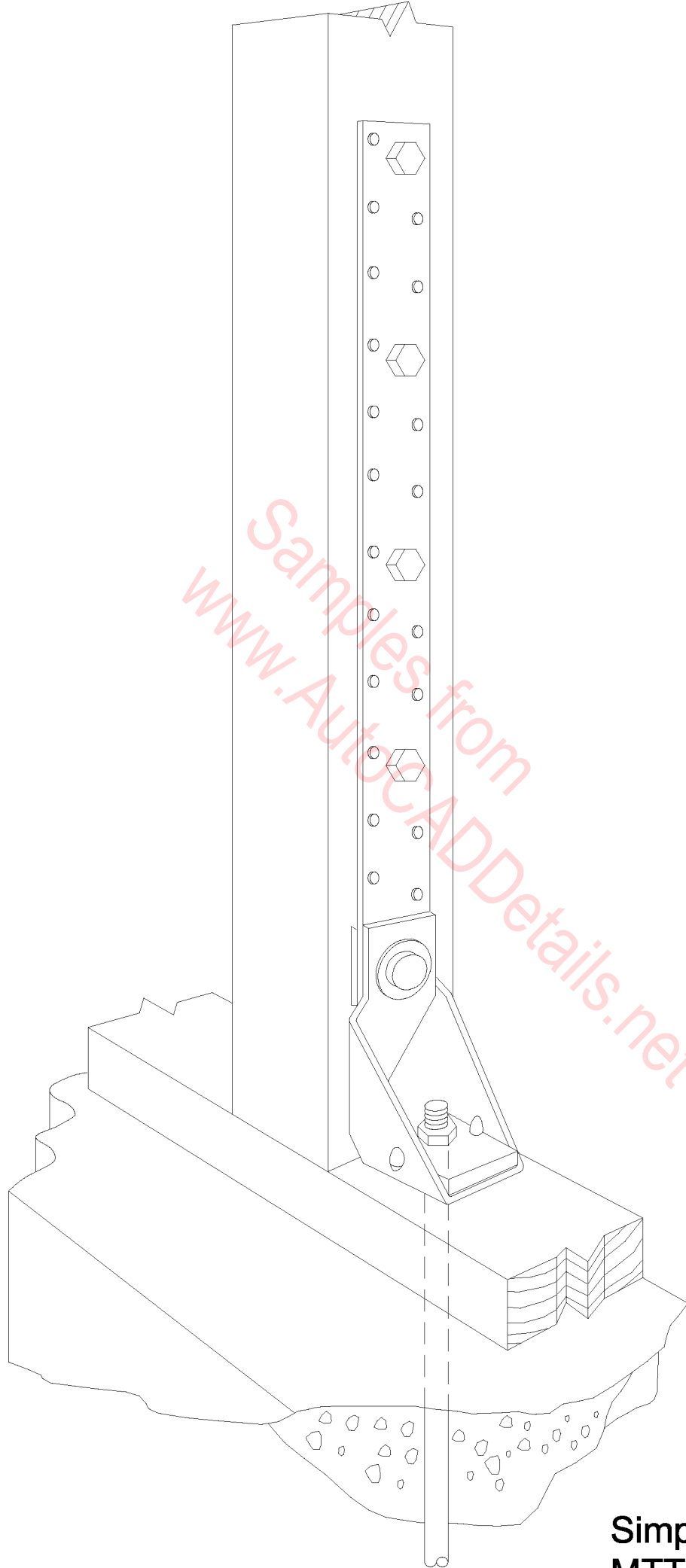

**Simpson Strong-Tie  
MTT28B**

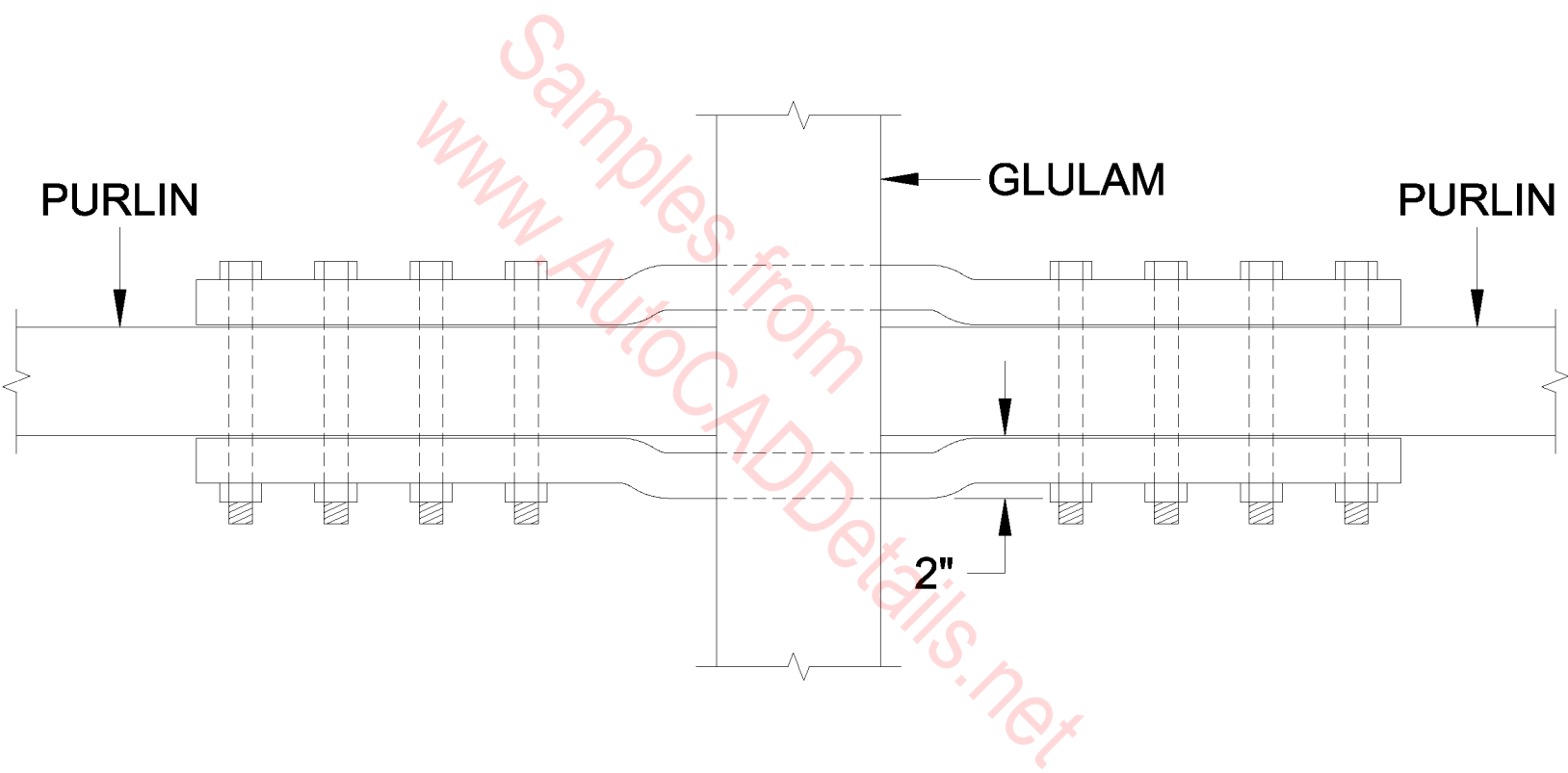

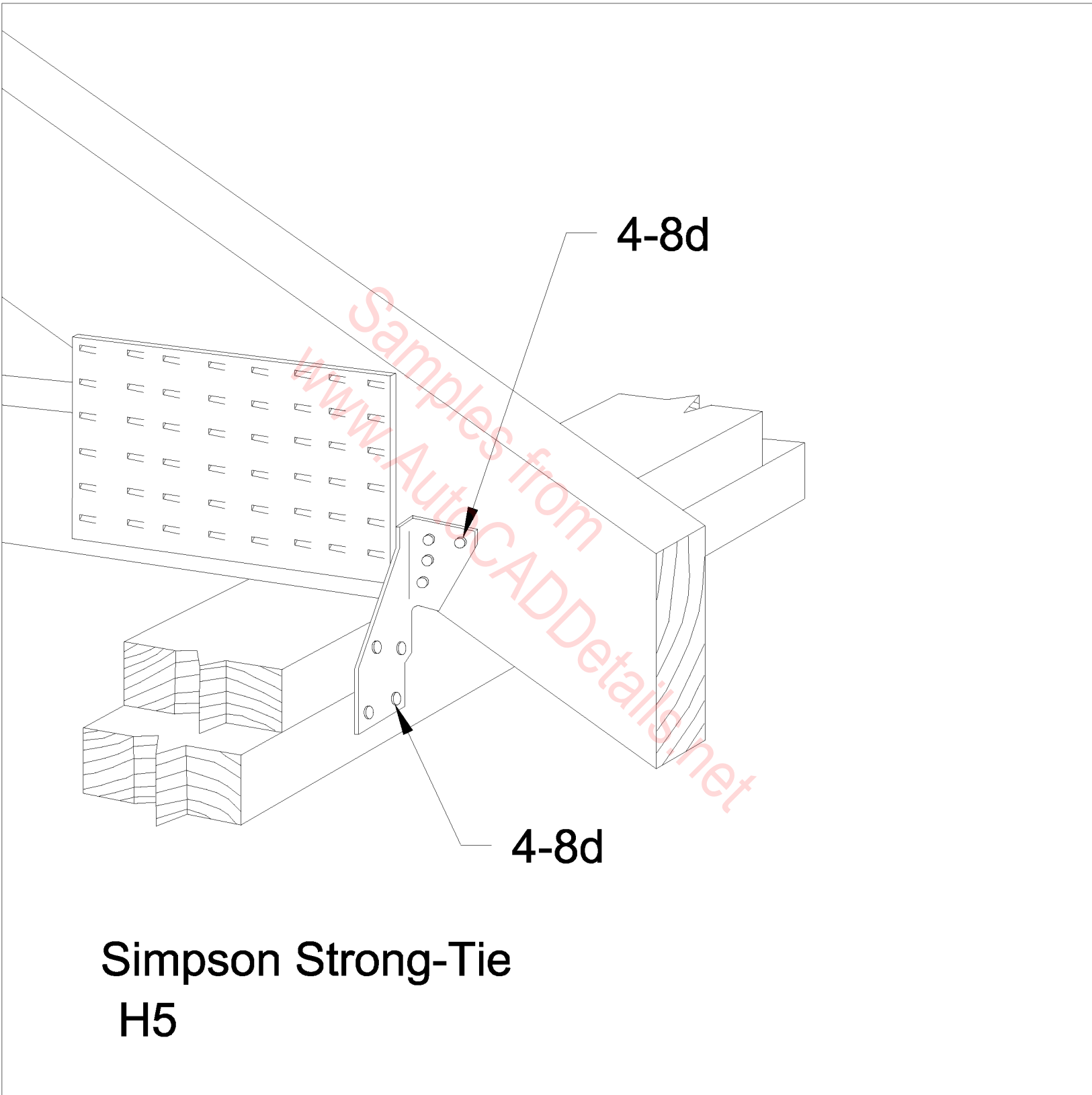

**INSTALL HALF OF  
FASTENERS @ EACH  
END OF STRAP**

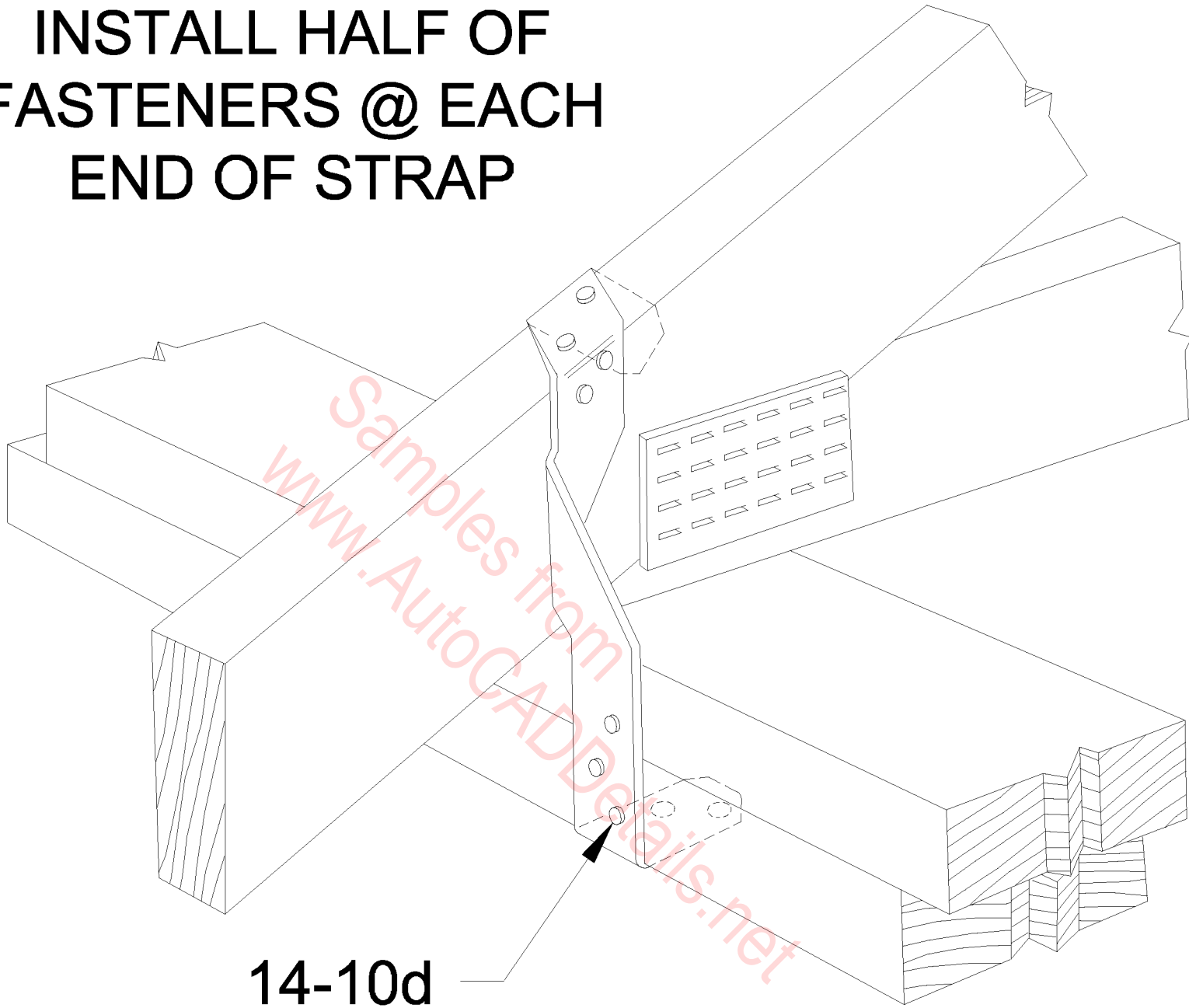

**14-10d  
(TOTAL)**

**Simpson Strong-Tie**

**MTS12**

**INSTALL HALF OF  
FASTENERS @ EACH  
END OF STRAP**

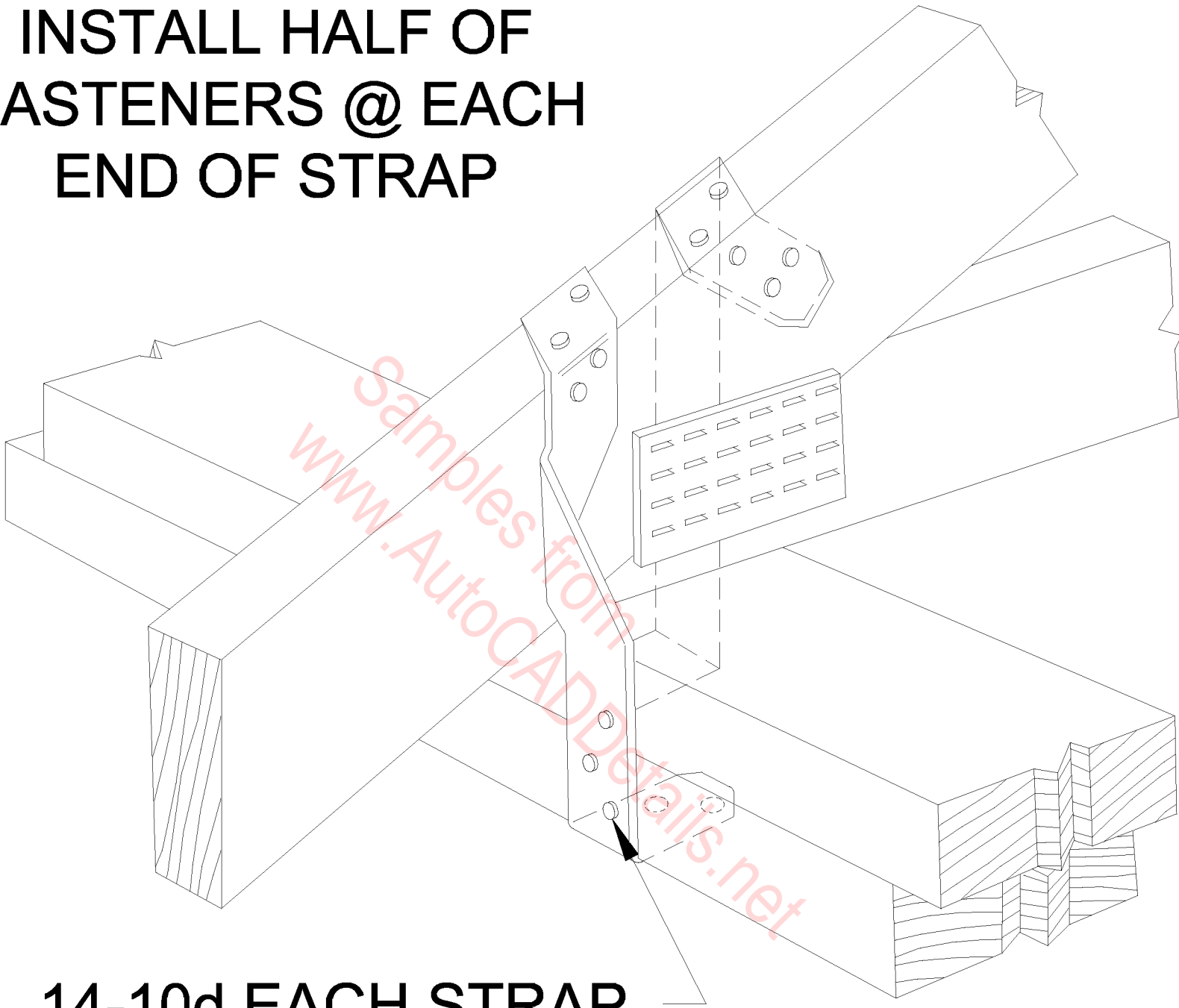

**14-10d EACH STRAP**

**Simpson Strong-Tie**

**(2) MTS12**

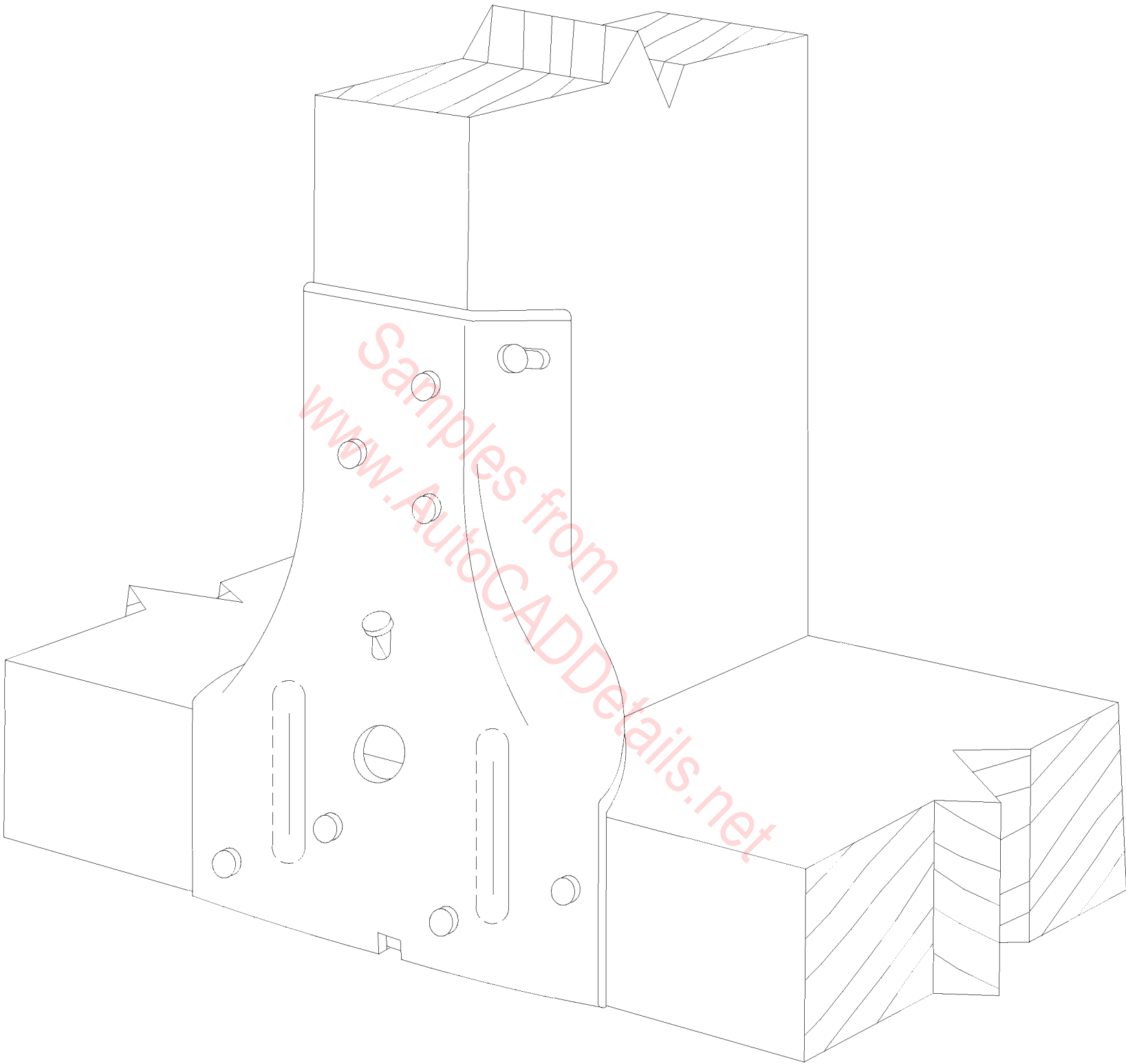

**Simpson Strong-Tie  
SP1**

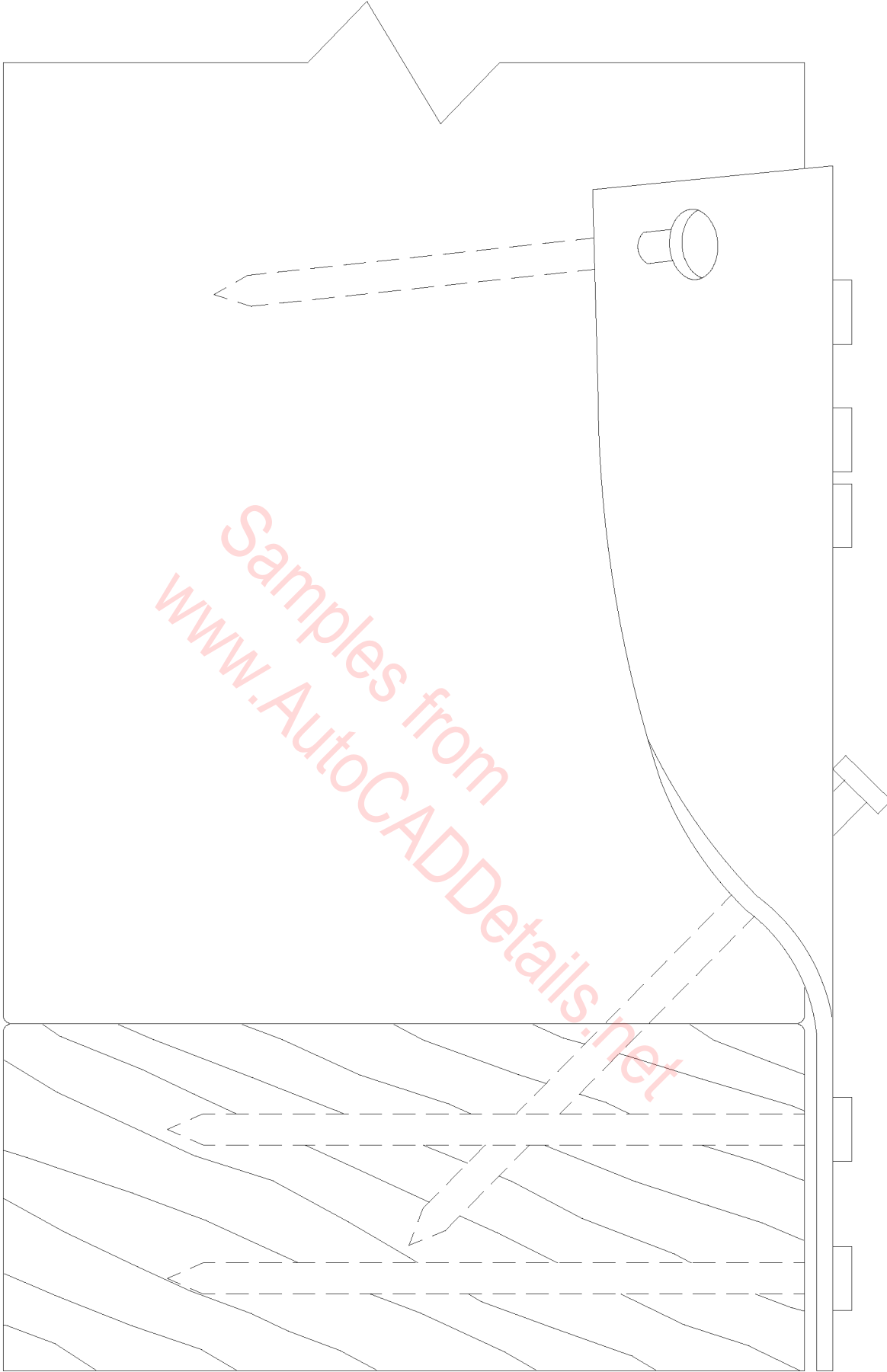

**Simpson Strong-Tie  
SP1**



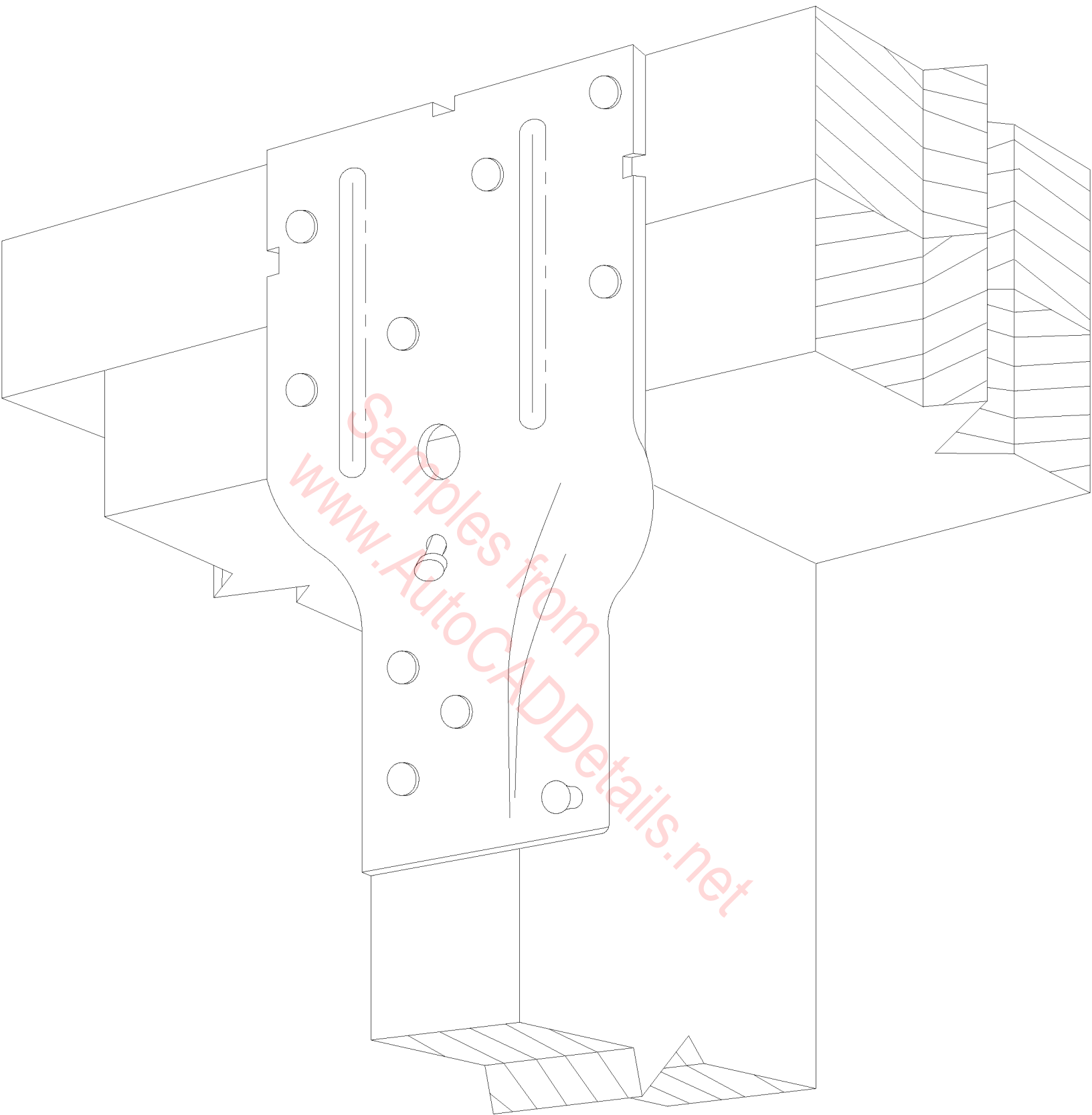

**Simpson Strong-Tie  
SP2**

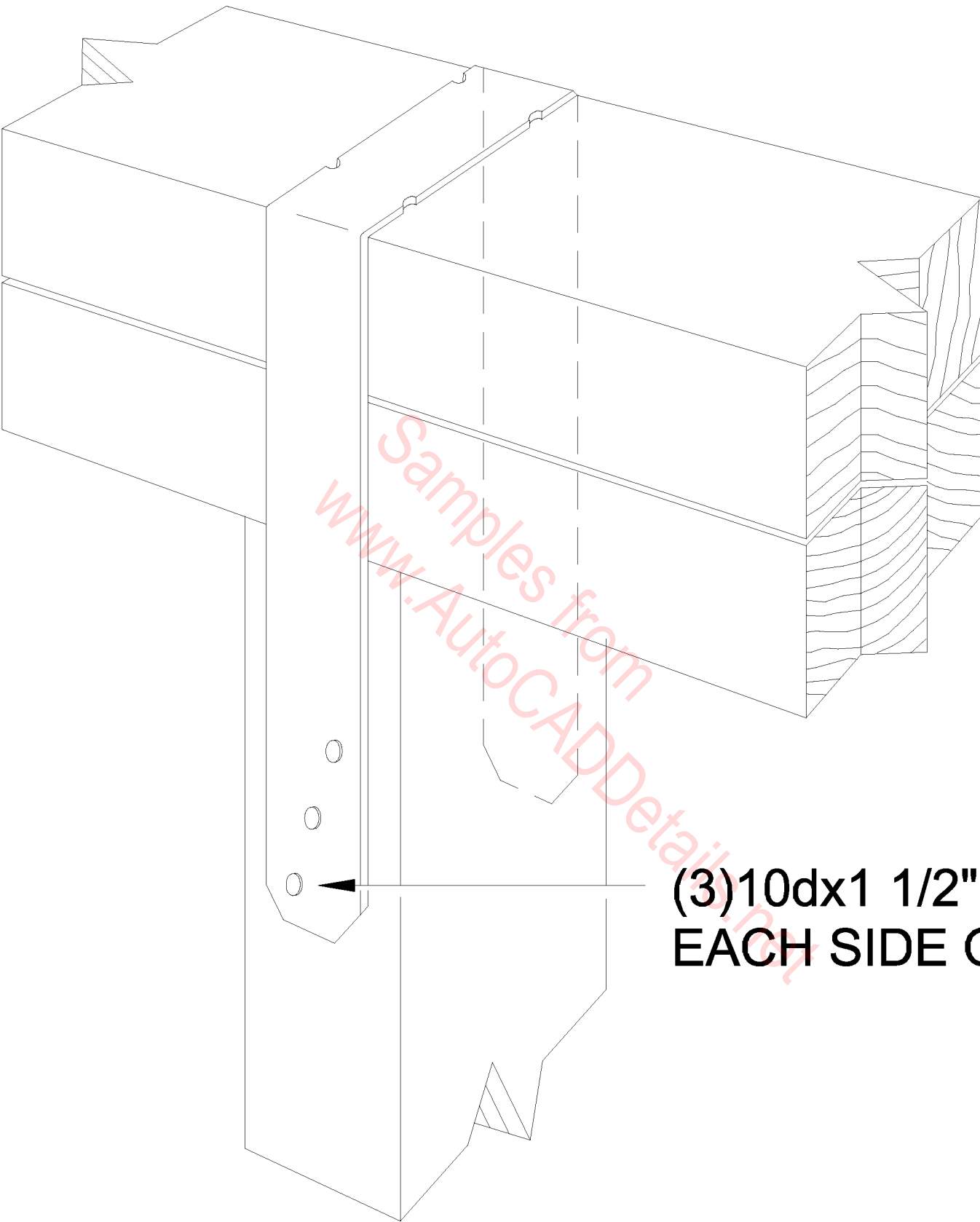

**(3) 10dx1 1/2" NAILS  
EACH SIDE OF STUD**

**Simpson Strong-Tie  
SP4**

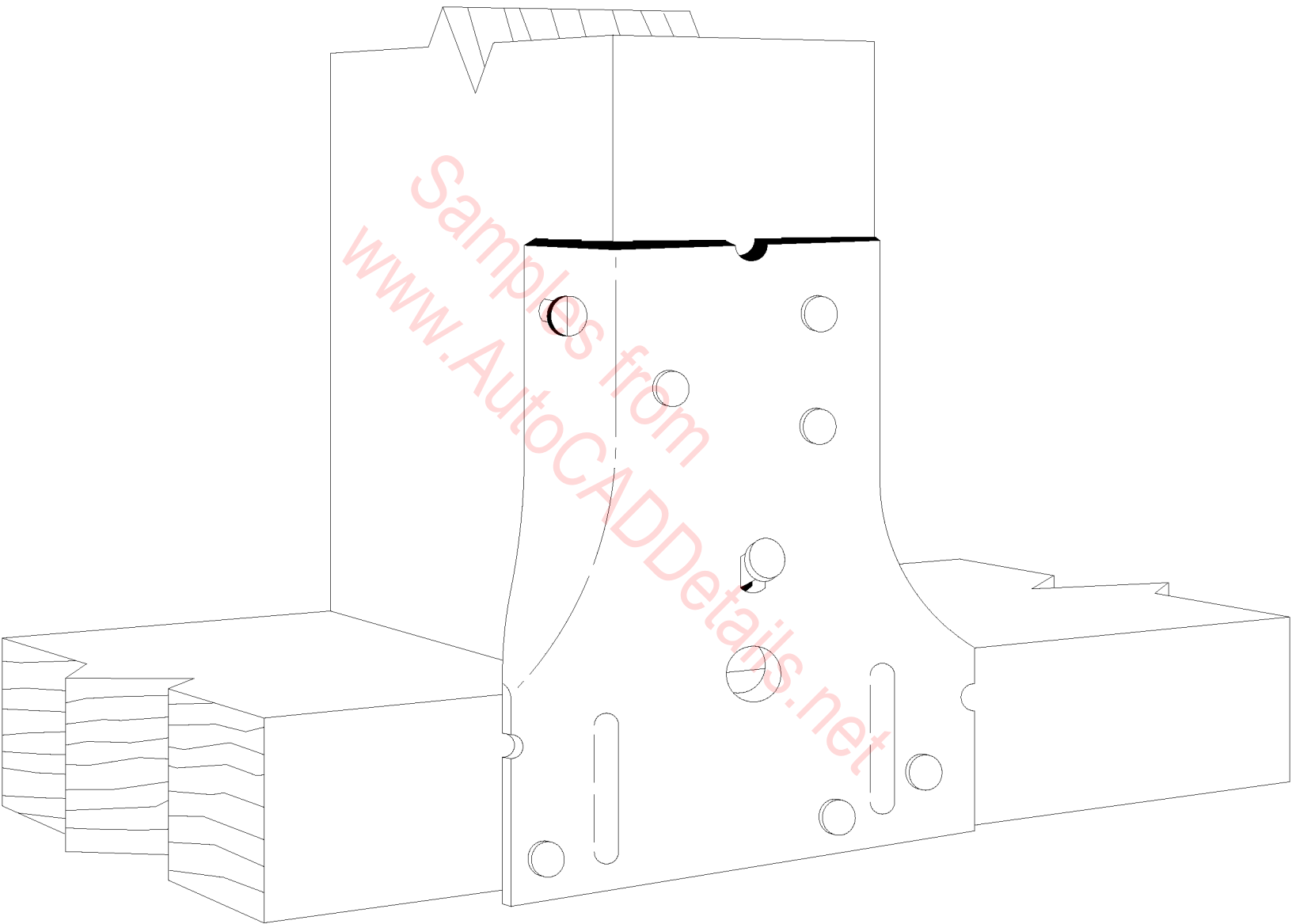

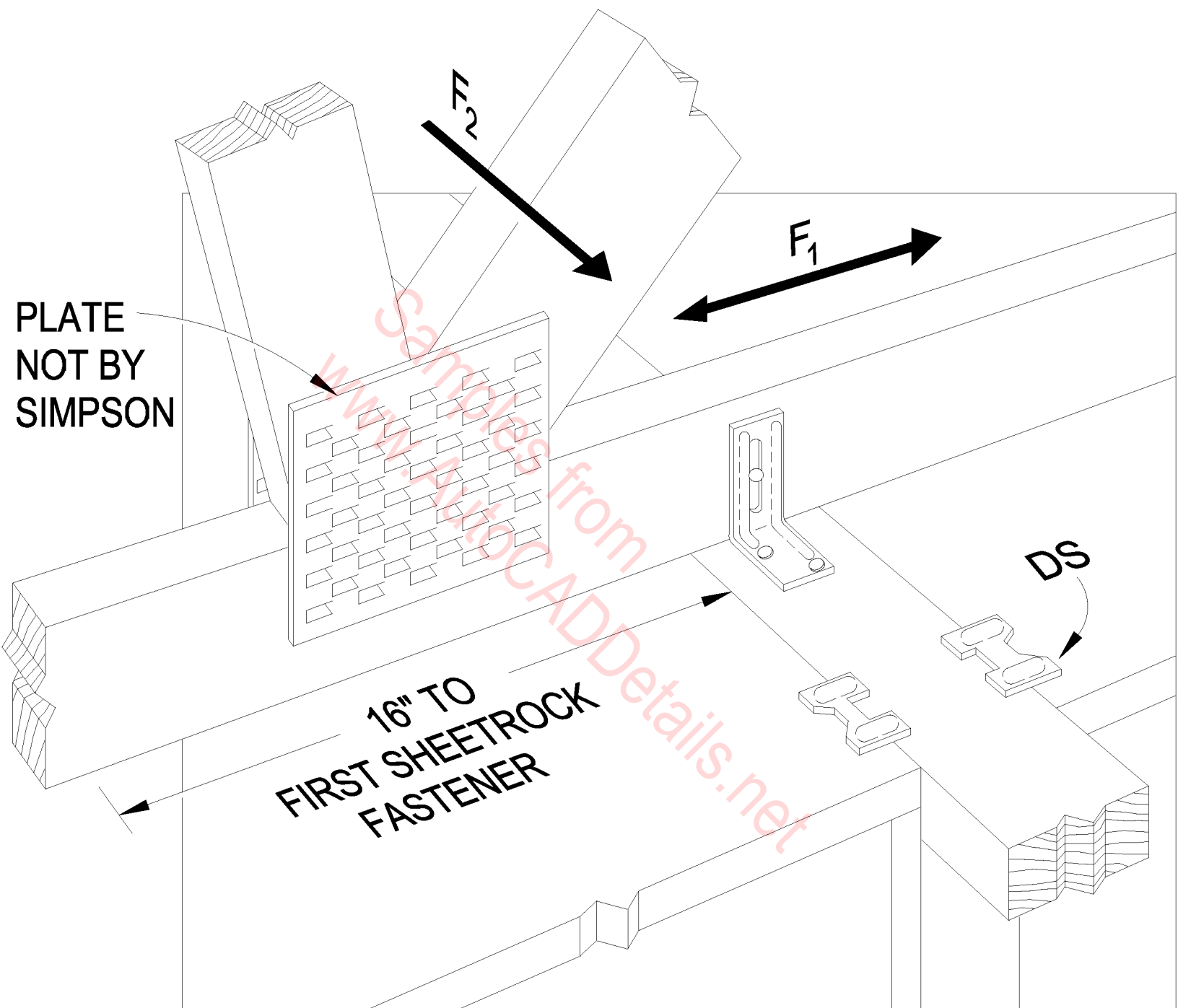

Simpson Strong-Tie  
STC

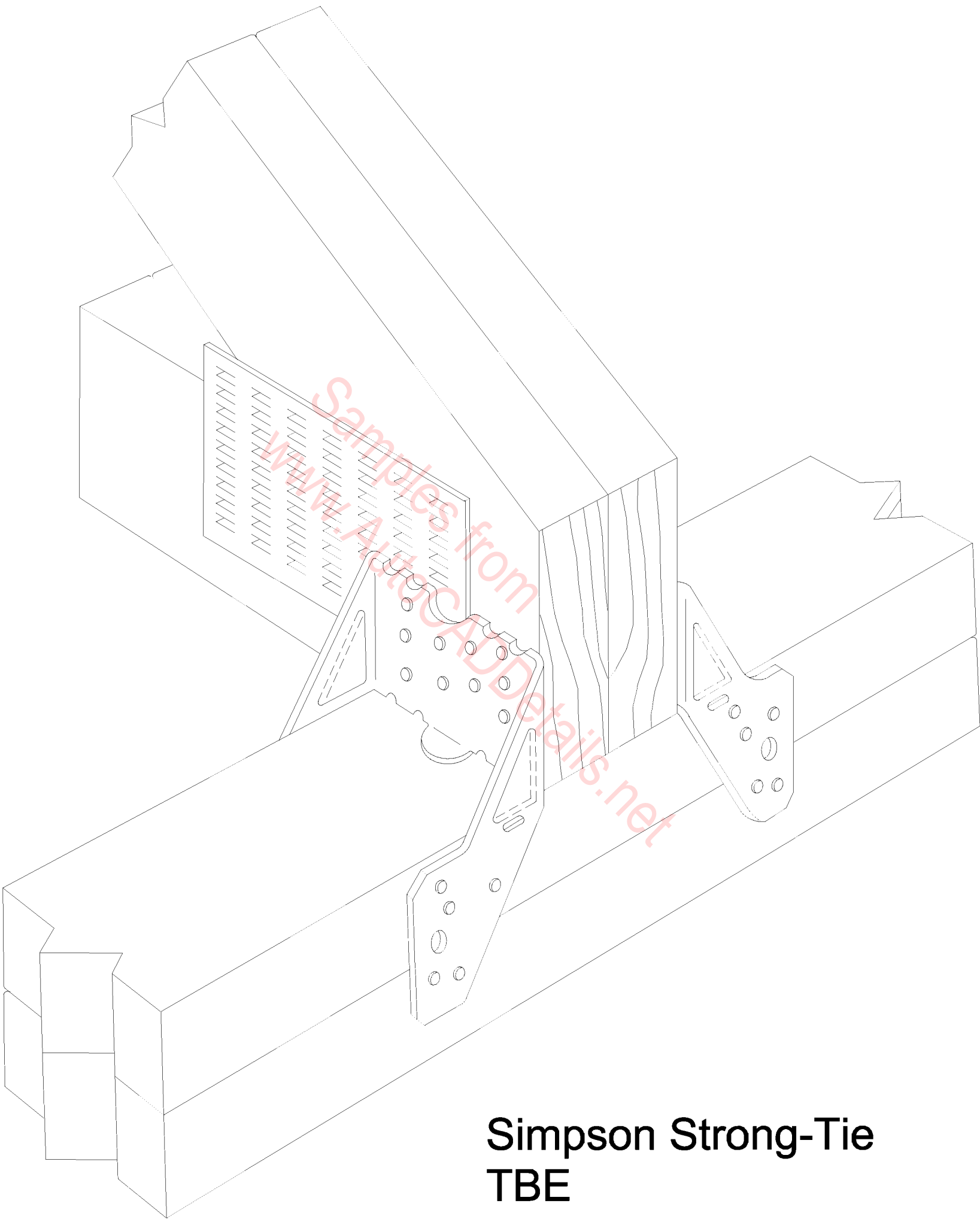

**Simpson Strong-Tie  
TBE**

**INSTALL NAILS TO  
ALLOW HORIZONTAL  
MOVEMENT OF  
SCISSORS TRUSS**

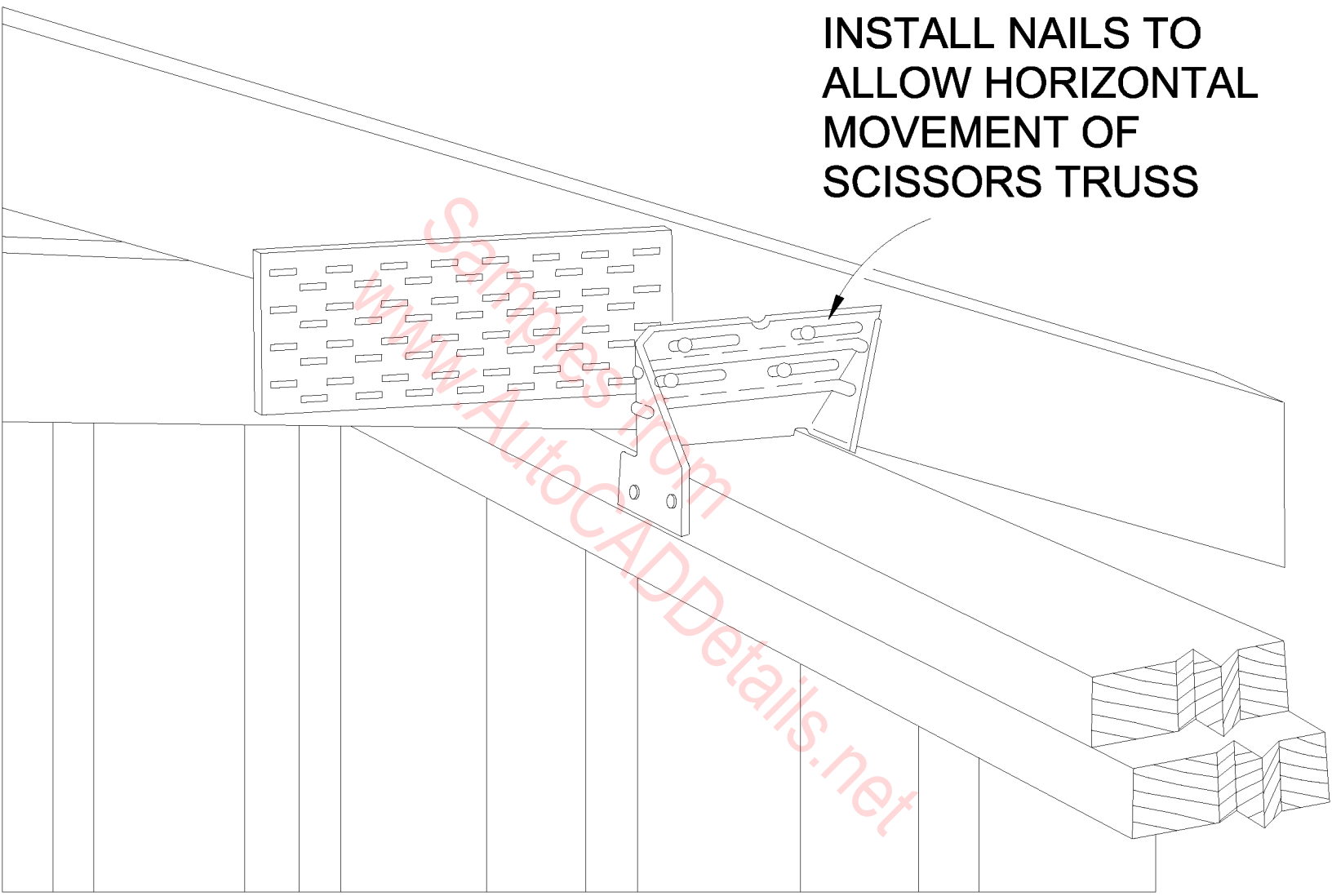

**Simpson Strong-Tie  
TC**

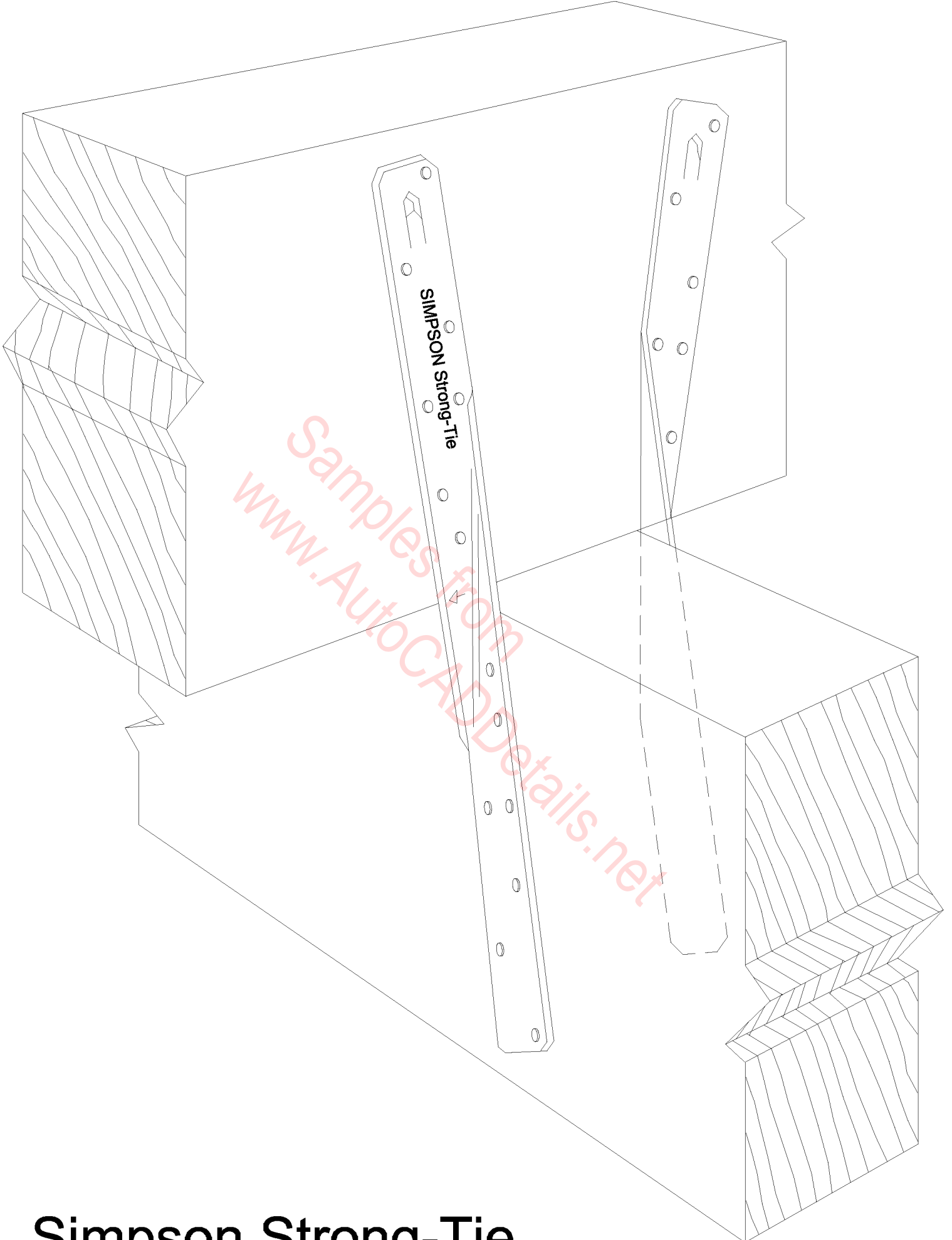

**Simpson Strong-Tie  
TS**

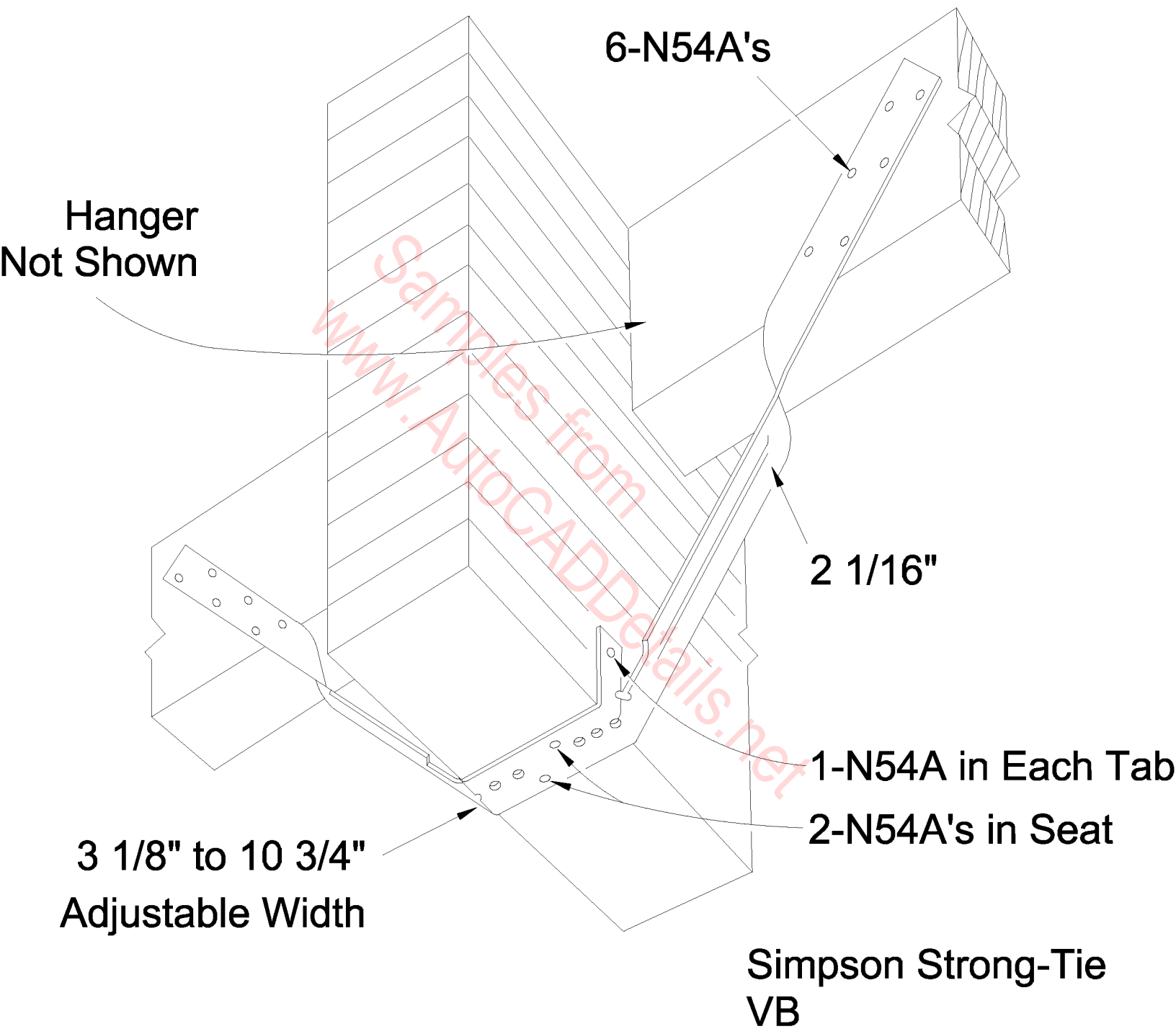



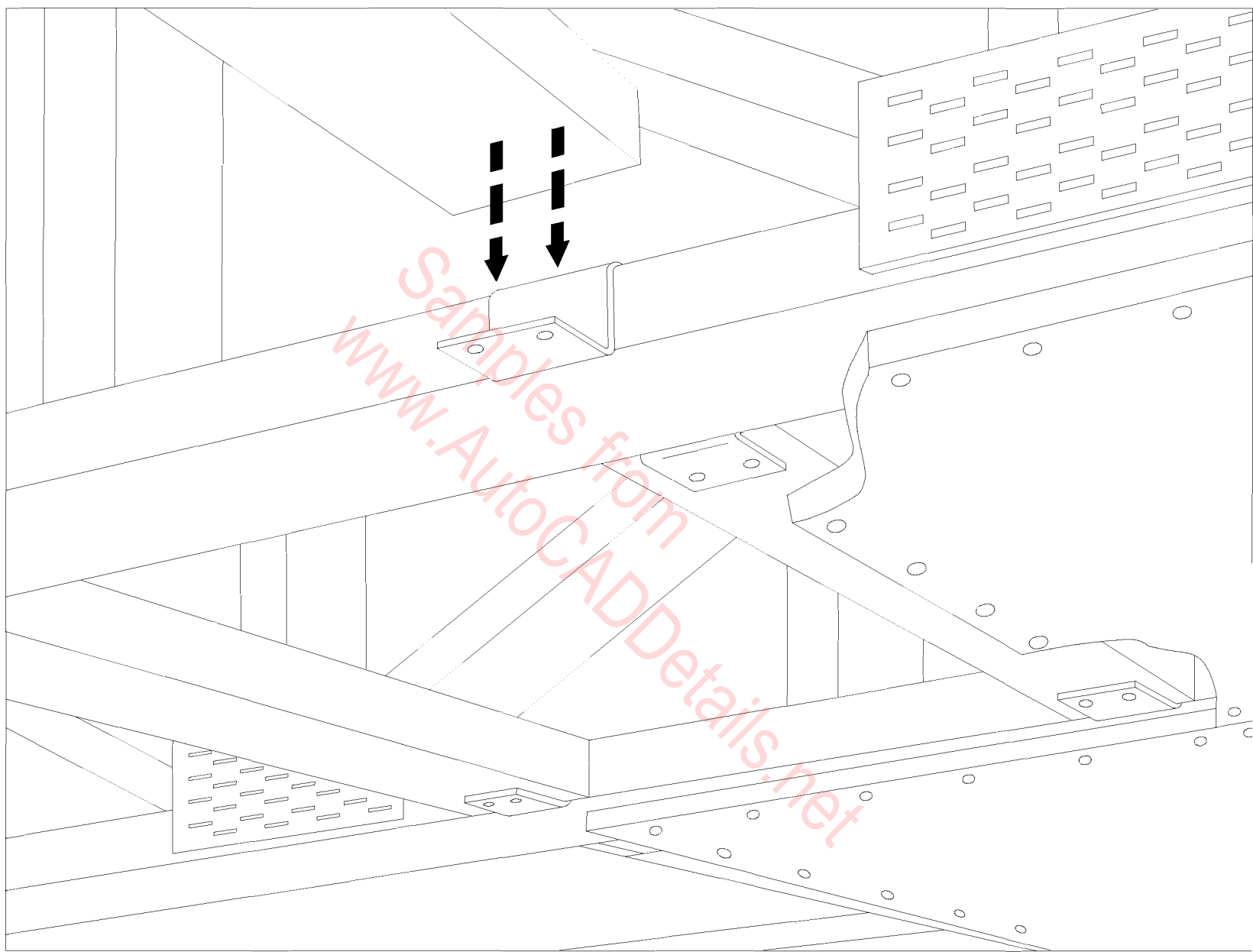

**Simpson Strong-Tie  
Z2**

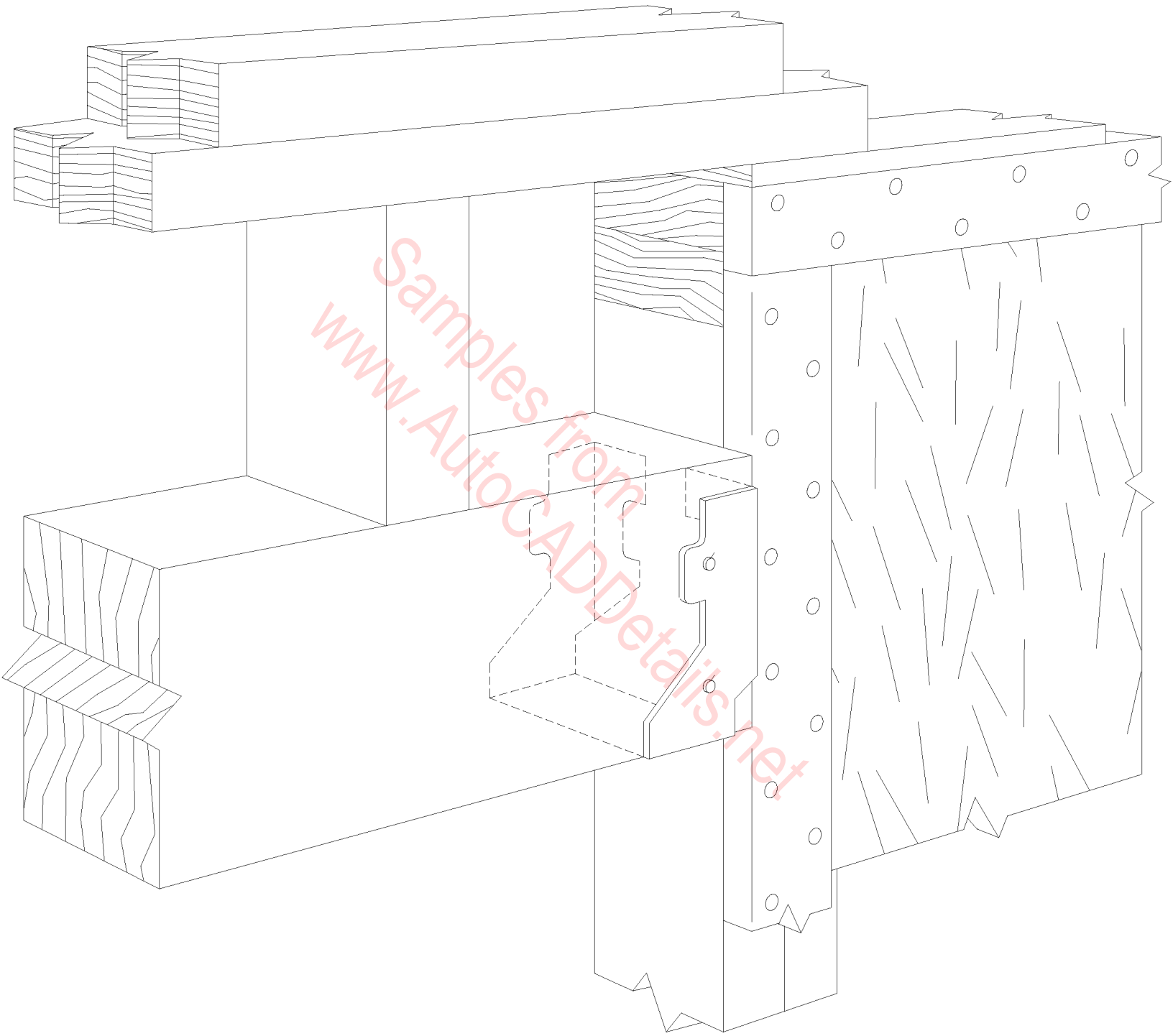





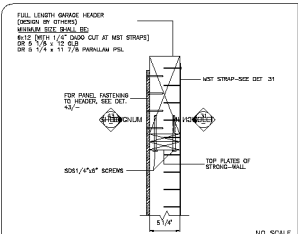

SECTION THRU 5.75" THK. STRONG-WALL 51

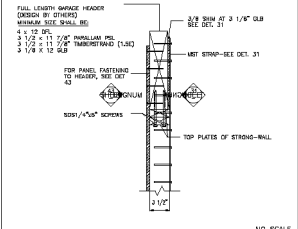

SECTION THRU 4" THK. STRONG-WALL 52

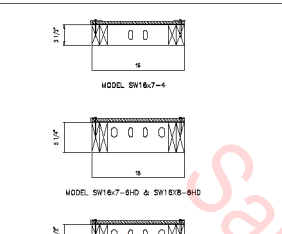

MODEL SW16x7-4

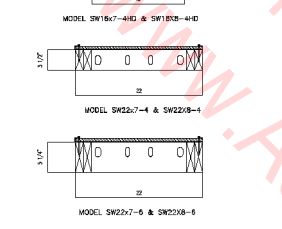

MODEL SW16x7-4HD & SW18x8-8HD

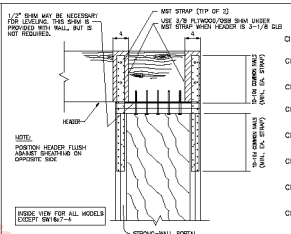

STRAP ATTACHMENT AT TOP 31

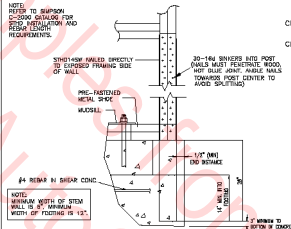

STRAP HOLDOWN AT SW16x7-4 NO SCALE 32

MARK	DESCRIPTION	INCLUDED	ON PANEL	DETAIL	REMARKS
CR10	1/2\"/>				
CR11	1/2\"/>				
CR12	1/2\"/>				
CR13	1/2\"/>				
CR14	1/2\"/>				
CR15	1/2\"/>				
CR16	1/2\"/>				
CR17	1/2\"/>				
CR18	1/2\"/>				
CR19	1/2\"/>				
CR20	1/2\"/>				
CR21	1/2\"/>				
CR22	1/2\"/>				
CR23	1/2\"/>				
CR24	1/2\"/>				
CR25	1/2\"/>				
CR26	1/2\"/>				
CR27	1/2\"/>				
CR28	1/2\"/>				
CR29	1/2\"/>				
CR30	1/2\"/>				
CR31	1/2\"/>				
CR32	1/2\"/>				
CR33	1/2\"/>				
CR34	1/2\"/>				
CR35	1/2\"/>				
CR36	1/2\"/>				
CR37	1/2\"/>				
CR38	1/2\"/>				
CR39	1/2\"/>				
CR40	1/2\"/>				
CR41	1/2\"/>				
CR42	1/2\"/>				
CR43	1/2\"/>				
CR44	1/2\"/>				
CR45	1/2\"/>				
CR46	1/2\"/>				
CR47	1/2\"/>				
CR48	1/2\"/>				
CR49	1/2\"/>				
CR50	1/2\"/>				
CR51	1/2\"/>				
CR52	1/2\"/>				
CR53	1/2\"/>				
CR54	1/2\"/>				
CR55	1/2\"/>				
CR56	1/2\"/>				
CR57	1/2\"/>				
CR58	1/2\"/>				
CR59	1/2\"/>				
CR60	1/2\"/>				
CR61	1/2\"/>				
CR62	1/2\"/>				
CR63	1/2\"/>				
CR64	1/2\"/>				
CR65	1/2\"/>				
CR66	1/2\"/>				
CR67	1/2\"/>				
CR68	1/2\"/>				
CR69	1/2\"/>				
CR70	1/2\"/>				
CR71	1/2\"/>				
CR72	1/2\"/>				
CR73	1/2\"/>				
CR74	1/2\"/>				
CR75	1/2\"/>				
CR76	1/2\"/>				
CR77	1/2\"/>				
CR78	1/2\"/>				
CR79	1/2\"/>				
CR80	1/2\"/>				
CR81	1/2\"/>				
CR82	1/2\"/>				
CR83	1/2\"/>				
CR84	1/2\"/>				
CR85	1/2\"/>				
CR86	1/2\"/>				
CR87	1/2\"/>				
CR88	1/2\"/>				
CR89	1/2\"/>				
CR90	1/2\"/>				
CR91	1/2\"/>				
CR92	1/2\"/>				
CR93	1/2\"/>				
CR94	1/2\"/>				
CR95	1/2\"/>				
CR96	1/2\"/>				
CR97	1/2\"/>				
CR98	1/2\"/>				
CR99	1/2\"/>				
CR100	1/2\"/>				

STRONG-WALL GARAGE PORTAL 12

MODEL	W (IN)	H (IN)	STRONG-WALL MODEL	STRONG-WALL W (IN)	STRONG-WALL H (IN)	STRONG-WALL W (IN)	STRONG-WALL H (IN)	STRONG-WALL W (IN)	STRONG-WALL H (IN)	STRONG-WALL W (IN)	STRONG-WALL H (IN)
SW16x7-4	16	7	SW16x7-4	16	7	SW16x7-4	16	7	SW16x7-4	16	7
SW16x7-4HD	16	7	SW16x7-4HD	16	7	SW16x7-4HD	16	7	SW16x7-4HD	16	7
SW18x8-8	18	8	SW18x8-8	18	8	SW18x8-8	18	8	SW18x8-8	18	8
SW18x8-8HD	18	8	SW18x8-8HD	18	8	SW18x8-8HD	18	8	SW18x8-8HD	18	8
SW22x7-6	22	7	SW22x7-6	22	7	SW22x7-6	22	7	SW22x7-6	22	7
SW22x7-6HD	22	7	SW22x7-6HD	22	7	SW22x7-6HD	22	7	SW22x7-6HD	22	7
SW22x8-6	22	8	SW22x8-6	22	8	SW22x8-6	22	8	SW22x8-6	22	8
SW22x8-6HD	22	8	SW22x8-6HD	22	8	SW22x8-6HD	22	8	SW22x8-6HD	22	8

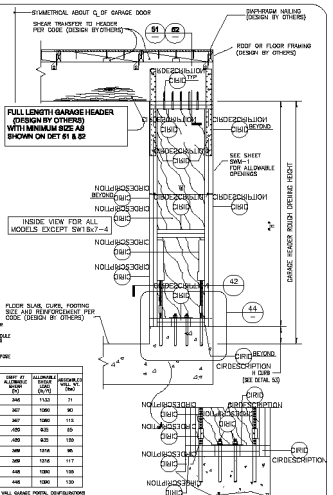

STRONG-WALL GARAGE PORTAL 12

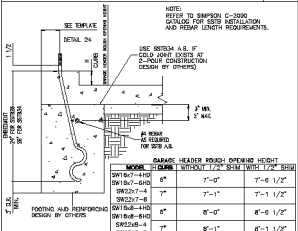

SSTB ANCHOR BOLT NO SCALE 53

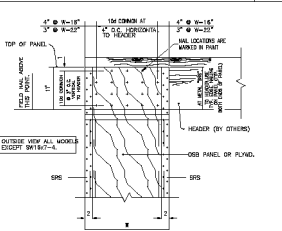

PANEL/HEADER CONNECTION NO SCALE 43

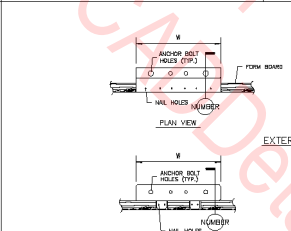

ANCHOR BOLT TEMPLATES NO SCALE 24

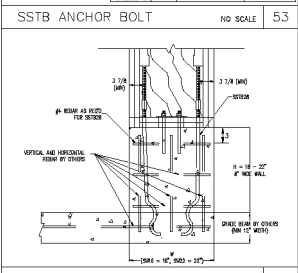

RAISED STEM WALL NO SCALE 54

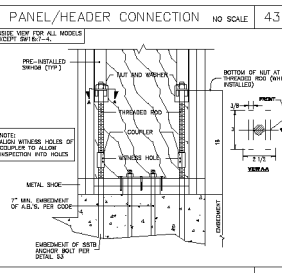

BOLTED SILL CONNECTION NO SCALE 44

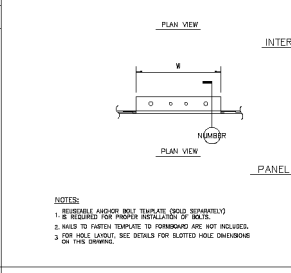

STRONG-WALL TEMPLATE SELECTION MATRIX NO SCALE 24

STRONG-WALL TEMPLATE SELECTION MATRIX

STRONG-WALL MODEL	W (IN)	STRONG-WALL MODEL	STRONG-WALL MODEL	STRONG-WALL MODEL
SW16x7-4	16	SW16x7-4HD	SW18x8-8	SW18x8-8HD
SW16x7-4HD	16	SW18x8-8	SW18x8-8HD	SW22x7-6
SW18x8-8	18	SW18x8-8HD	SW22x7-6	SW22x7-6HD
SW18x8-8HD	18	SW22x7-6	SW22x7-6HD	SW22x8-6
SW22x7-6	22	SW22x7-6HD	SW22x8-6	SW22x8-6HD
SW22x7-6HD	22	SW22x8-6	SW22x8-6HD	
SW22x8-6	22	SW22x8-6HD		
SW22x8-6HD	22			

STRONG-WALL TEMPLATE SELECTION MATRIX NO SCALE 24

1. STRONG-WALL IS MANUFACTURED AND TRADEMARKED BY SIMPSON STRONG-TIE COMPANY, INC. HOME OFFICE: 1437 CHERRY DR., #200, PLEASANTON, CA 94588 TEL: (925) 899-3089, FAX: (925) 847-3098 SIMPSON STRONG-TIE COMPANY, INC. IS AN ISO 9001 REGISTERED COMPANY.

2. STRONG-WALL IS APPROVED BY THE INTERNATIONAL CONFERENCE OF BUILDING OFFICIALS (ICBO) RECOMMENDATION NO. E-3480. INSTALLATION BY PRODUCT SHALL BE DONE IN STRICT CONFORMANCE TO THAT DOCUMENT AND TO THESE DRAWINGS. MODIFICATIONS TO THIS PRODUCT AND ASSOCIATED SYSTEMS OR CHANGES IN THE INSTALLATION METHODS SHOWN ON THESE DRAWINGS OR REFERENCED IN THIS REPORT SHOULD ONLY BE MADE BY A QUALIFIED ARCHITECT, CIVIL OR STRUCTURAL ENGINEER. THE PERFORMANCE OF SUCH MODIFIED PRODUCTS OR ALTERED INSTALLATION PROCEDURES IS THE SOLE RESPONSIBILITY OF THE DESIGNER.

3. THE CONTRACTOR SHALL VERIFY ALL DIMENSIONS, CONDITIONS, ELEVATIONS, ETC. PRIOR TO INSTALLATION OF ANY COMPONENTS FOR THE STRONG-WALL SYSTEM. IF ANY DISCREPANCIES ARE FOUND, THEY SHALL BE BROUGHT TO THE ATTENTION OF THE PROJECT ARCHITECT, PROJECT ENGINEER OR BUILDING DESIGNER FOR CLARIFICATION PRIOR TO CONSTRUCTION.

4. THE CONTRACTOR SHALL VERIFY THE POSITION OF THE STRONG-WALL IN RELATION TO THE REST OF THE BUILDING SYSTEM AS SHOWN ON THE PROJECT DRAWINGS.

5. USE OF THIS PRODUCT IS SUBJECT TO THE APPROVAL OF THE LOCAL BUILDING OFFICIAL.

6. THE BUILDING STRUCTURE SHALL BE DESIGNED IN ACCORDANCE WITH THE LATEST ADOPTED EDITION OF THE UNIFORM BUILDING CODE AND ANY OTHER LOCAL, STATE OR FEDERAL REQUIREMENTS THAT MAY APPLY. VERIFY DESIGN REQUIREMENTS WITH THE LOCAL BUILDING DEPARTMENT.

7. THIS PRODUCT IS PART OF THE OVERALL LATERAL FORCE RESISTING SYSTEM OF THE STRUCTURE. DESIGN OF THE BUILDING'S LATERAL FORCE RESISTING SYSTEM, INCLUDING A COMPLETE LOAD PATH NECESSARY TO TRANSFER LATERAL FORCES FROM THE STRUCTURE TO THE GROUND, IS THE RESPONSIBILITY OF THE DESIGNER.

8. SIMPSON STRONG-TIE COMPANY, INC. RESERVES THE RIGHT TO CHANGE SPECIFICATIONS, DETAILS AND MODELS WITHOUT NOTICE OR LIABILITY FOR SUCH CHANGES.

9. ALL HARDWARE CALLED OUT IS SIMPSON STRONG-TIE.

NOTES

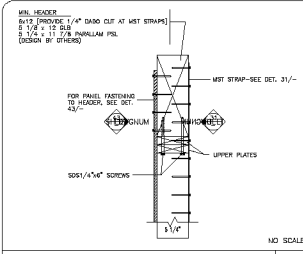

SECTION THRU 6" NOM. STRONG-WALL 51

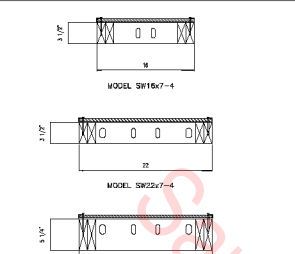

NO SCALE

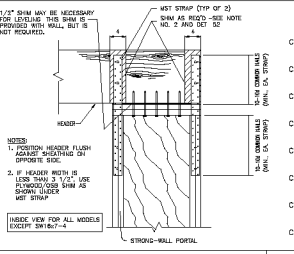

STRAP ATTACHMENT AT TOP NO SCALE

MARK	DESCRIPTION	INCLUDED	PRE-INSTALLED ON PANEL	DETAIL	REMARKS
CR1001	1/2" MIN. SHIM	Y	Y		
CR1002	MIN. HEADER	Y	Y	1	
CR1003	MIN. STRAP	Y	Y		
CR1004	MIN. WALL SHIRT	Y	N	2	
CR1005	MIN. STRAP	Y	N		
CR1006	MIN. STRAP	Y	N		
CR1007	MIN. STRAP	Y	N		
CR1008	MIN. STRAP	Y	N		
CR1009	MIN. STRAP	Y	N		
CR1010	MIN. STRAP	Y	N		
CR1011	MIN. STRAP	Y	N		
CR1012	MIN. STRAP	Y	N		
CR1013	MIN. STRAP	Y	N		
CR1014	MIN. STRAP	Y	N		
CR1015	MIN. STRAP	Y	N		
CR1016	MIN. STRAP	Y	N		
CR1017	MIN. STRAP	Y	N		
CR1018	MIN. STRAP	Y	N		
CR1019	MIN. STRAP	Y	N		
CR1020	MIN. STRAP	Y	N		

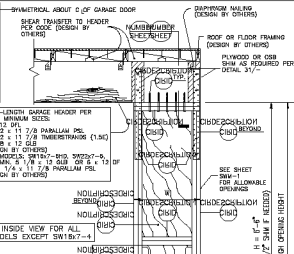

STRONG-WALL GARAGE PORTAL NO SCALE

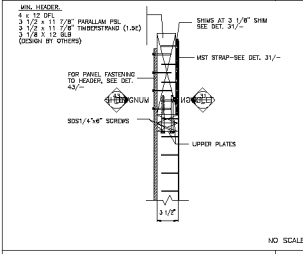

SECTION THRU 4" NOM. STRONG-WALL 52

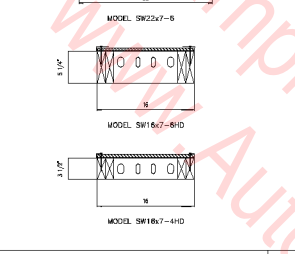

SLOTTED HOLE LAYOUT NO SCALE

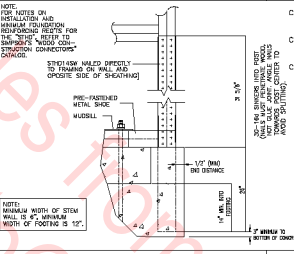

STRAP HOLDOWN AT SW16x7-4 NO SCALE

STRAP	#	SIZE	GRADE	NUMBER OF ANCHORS	MINIMUM EMBEDMENT (IN)	MINIMUM SPACING (IN)	MINIMUM END DISTANCE (IN)	MINIMUM END DISTANCE (IN)	MINIMUM END DISTANCE (IN)	MINIMUM END DISTANCE (IN)
SW16x7-4	16	A-36	3-PLY	16000	2000	2000	2000	2000	2000	2000
SW22x7-4	22	A-36	3-PLY	22000	2000	2000	2000	2000	2000	2000
SW16x7-6HD	16	A-36	3-PLY	16000	2000	2000	2000	2000	2000	2000
SW22x7-6HD	22	A-36	3-PLY	22000	2000	2000	2000	2000	2000	2000

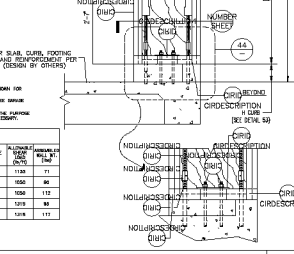

STRONG-WALL GARAGE PORTAL NO SCALE

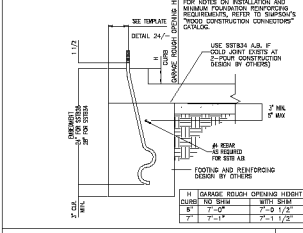

SSTB ANCHOR BOLT NO SCALE

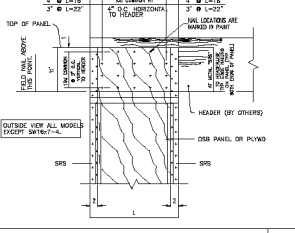

PANEL/HEADER CONNECTION NO SCALE

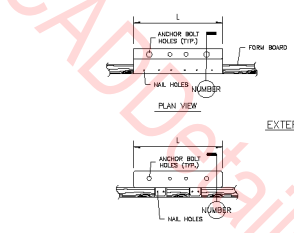

ANCHOR BOLT TEMPLATES NO SCALE

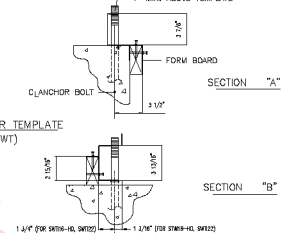

STRONG-WALL GARAGE PORTAL NO SCALE

- STRONG-WALL IS MANUFACTURED AND TRADEMARKED BY SIMPSON STRONG-TIE COMPANY, INC. HOME OFFICE: 3851 GARDEN RD., #200, PLEASANTON, CA 94588. TEL: (925) 899-5089, FAX: (925) 847-3008. SIMPSON STRONG-TIE COMPANY, INC. IS AN ISO 9001 REGISTERED COMPANY.
- STRONG-WALL IS RECOGNIZED BY THE INTERNATIONAL CONFERENCE OF BUILDING OFFICIALS (I.C.B.O. REGISTRATION NO. PFC-5485). INSTALLATION OF PRODUCT SHALL BE DONE IN STRICT CONFORMANCE TO THIS DOCUMENT AND TO THESE DRAWINGS. MODIFICATIONS TO THIS PRODUCT AND ASSOCIATED SYSTEMS OR CHANGES IN THE INSTALLATION METHODS SHOWN ON THESE DRAWINGS OR RETROFITTED TO THIS PRODUCT SHOULD ONLY BE MADE BY A QUALIFIED ARCHITECT, CIVIL OR STRUCTURAL ENGINEER. THE PERFORMANCE OF SUCH MODIFIED PRODUCTS OR ALTERED INSTALLATION PROCEDURES IS THE SOLE RESPONSIBILITY OF THE DESIGNER.
- THE CONTRACTOR SHALL VERIFY ALL DIMENSIONS, CONDITIONS, ELEVATIONS, ETC. PRIOR TO INSTALLATION OF ANY COMPONENTS FOR THE STRONG-WALL SYSTEM. IF ANY DISCREPANCIES ARE FOUND, THEY SHALL BE BROUGHT TO THE ATTENTION OF THE PROJECT ARCHITECT, PROJECT ENGINEER OR BUILDING DESIGNER FOR CLARIFICATION PRIOR TO CONSTRUCTION.
- THE CONTRACTOR SHALL VERIFY THE POSITION OF THE STRONG-WALL IN RELATION TO THE REST OF THE BUILDING SYSTEM AS SHOWN ON THE PROJECT DRAWINGS.
- USE OF THIS PRODUCT IS SUBJECT TO THE APPROVAL OF THE LOCAL BUILDING OFFICIAL.
- THE BUILDING STRUCTURE SHALL BE DESIGNED IN ACCORDANCE WITH THE LATEST ADOPTED VERSION OF THE UNIFORM BUILDING CODE AND ANY OTHER LOCAL, STATE OR FEDERAL REQUIREMENTS THAT MAY APPLY. VERIFY DESIGN REQUIREMENTS WITH THE LOCAL BUILDING OFFICIAL.
- THIS PRODUCT IS PART OF THE OVERALL LATERAL FORCE RESISTING SYSTEM OF THE STRUCTURE. DESIGN OF THE BUILDING'S LATERAL FORCE RESISTING SYSTEM, INCLUDING A COMPLETE LOAD PATH NECESSARY TO TRANSFER LATERAL FORCES FROM THE STRUCTURE TO THE GROUND, IS THE RESPONSIBILITY OF THE DESIGNER.
- SIMPSON STRONG-TIE COMPANY, INC. RESERVES THE RIGHT TO CHANGE SPECIFICATIONS, DESIGNS AND MODELS WITHOUT NOTICE OR LIABILITY FOR SUCH CHANGES.
- ALL HARDWARE CALLED OUT IS SIMPSON STRONG-TIE.

NOTES

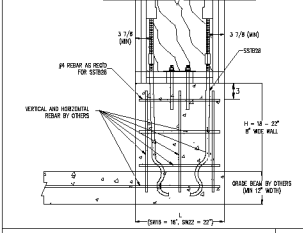

RAISED STEMWALL 54

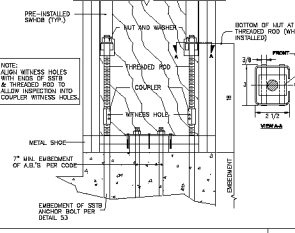

BOLTED SILL NO SCALE

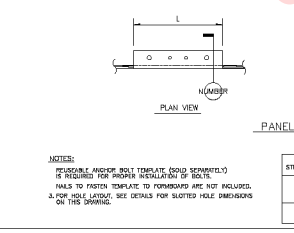

ANCHOR BOLT TEMPLATES NO SCALE

STRONG-WALL MODEL	LENGTH (ft)	EXTERIOR	INTERIOR	PANEL FORM
SW16x7-4	16	SW16-HD	SW16-ID	SW16F-HD
SW22x7-4	22	SW22	SW22	SW22F
SW16x7-6HD	16	SW16-HD	SW16-ID	SW16F-HD
SW22x7-6HD	22	SW22	SW22	SW22F

- STRONG-WALL IS MANUFACTURED AND TRADEMARKED BY SIMPSON STRONG-TIE COMPANY, INC. HOME OFFICE: 3851 GARDEN RD., #200, PLEASANTON, CA 94588. TEL: (925) 899-5089, FAX: (925) 847-3008. SIMPSON STRONG-TIE COMPANY, INC. IS AN ISO 9001 REGISTERED COMPANY.
- STRONG-WALL IS RECOGNIZED BY THE INTERNATIONAL CONFERENCE OF BUILDING OFFICIALS (I.C.B.O. REGISTRATION NO. PFC-5485). INSTALLATION OF PRODUCT SHALL BE DONE IN STRICT CONFORMANCE TO THIS DOCUMENT AND TO THESE DRAWINGS. MODIFICATIONS TO THIS PRODUCT AND ASSOCIATED SYSTEMS OR CHANGES IN THE INSTALLATION METHODS SHOWN ON THESE DRAWINGS OR RETROFITTED TO THIS PRODUCT SHOULD ONLY BE MADE BY A QUALIFIED ARCHITECT, CIVIL OR STRUCTURAL ENGINEER. THE PERFORMANCE OF SUCH MODIFIED PRODUCTS OR ALTERED INSTALLATION PROCEDURES IS THE SOLE RESPONSIBILITY OF THE DESIGNER.
- THE CONTRACTOR SHALL VERIFY ALL DIMENSIONS, CONDITIONS, ELEVATIONS, ETC. PRIOR TO INSTALLATION OF ANY COMPONENTS FOR THE STRONG-WALL SYSTEM. IF ANY DISCREPANCIES ARE FOUND, THEY SHALL BE BROUGHT TO THE ATTENTION OF THE PROJECT ARCHITECT, PROJECT ENGINEER OR BUILDING DESIGNER FOR CLARIFICATION PRIOR TO CONSTRUCTION.
- THE CONTRACTOR SHALL VERIFY THE POSITION OF THE STRONG-WALL IN RELATION TO THE REST OF THE BUILDING SYSTEM AS SHOWN ON THE PROJECT DRAWINGS.
- USE OF THIS PRODUCT IS SUBJECT TO THE APPROVAL OF THE LOCAL BUILDING OFFICIAL.
- THE BUILDING STRUCTURE SHALL BE DESIGNED IN ACCORDANCE WITH THE LATEST ADOPTED VERSION OF THE UNIFORM BUILDING CODE AND ANY OTHER LOCAL, STATE OR FEDERAL REQUIREMENTS THAT MAY APPLY. VERIFY DESIGN REQUIREMENTS WITH THE LOCAL BUILDING OFFICIAL.
- THIS PRODUCT IS PART OF THE OVERALL LATERAL FORCE RESISTING SYSTEM OF THE STRUCTURE. DESIGN OF THE BUILDING'S LATERAL FORCE RESISTING SYSTEM, INCLUDING A COMPLETE LOAD PATH NECESSARY TO TRANSFER LATERAL FORCES FROM THE STRUCTURE TO THE GROUND, IS THE RESPONSIBILITY OF THE DESIGNER.
- SIMPSON STRONG-TIE COMPANY, INC. RESERVES THE RIGHT TO CHANGE SPECIFICATIONS, DESIGNS AND MODELS WITHOUT NOTICE OR LIABILITY FOR SUCH CHANGES.
- ALL HARDWARE CALLED OUT IS SIMPSON STRONG-TIE.

NOTES

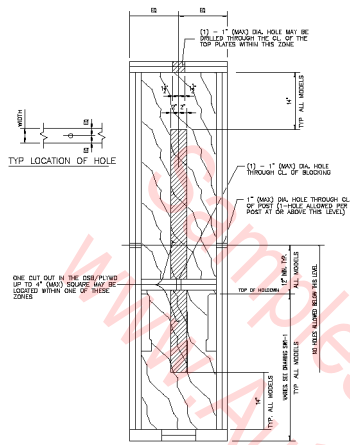

MODEL SW24  
ALLOWABLE HOLE LOCATIONS

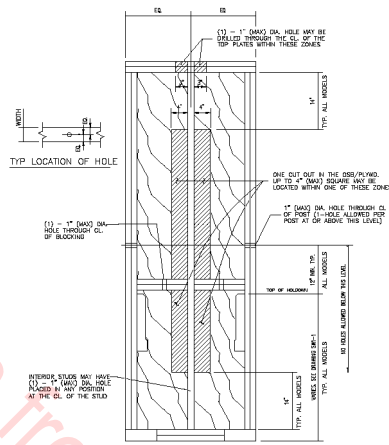

MODEL SW32  
ALLOWABLE HOLE LOCATIONS

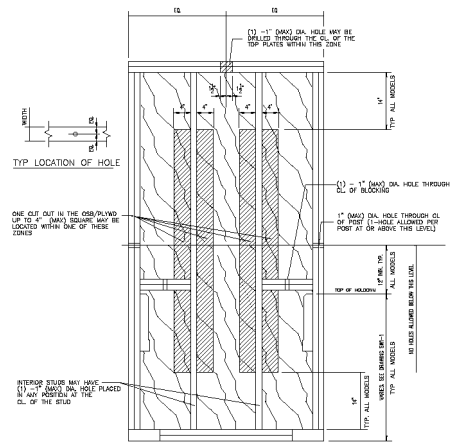

MODEL SW48  
ALLOWABLE HOLE LOCATIONS

ALLOWABLE HOLE LOCATIONS

NO SCALE 12

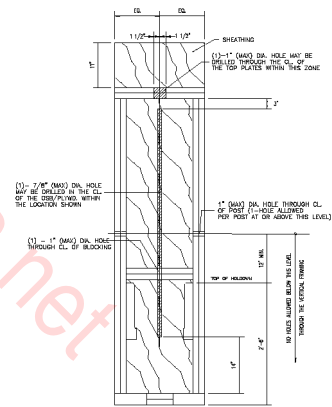

SW16x7HD AND SW22x7  
ALLOWABLE HOLE LOCATIONS

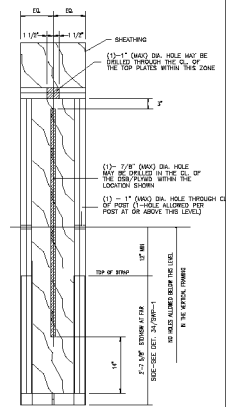

SW16x7  
ALLOWABLE HOLE LOCATIONS

ALLOWABLE HOLE LOCATIONS (GARAGE PORTAL)

14





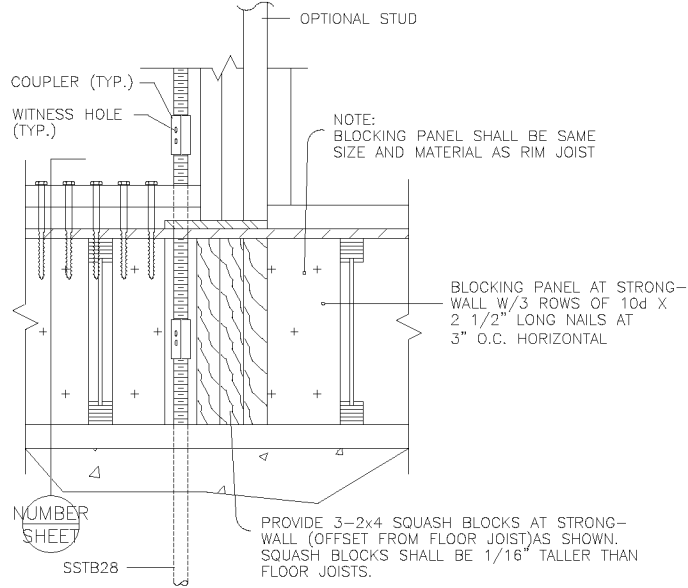

BOTTOM OF STRONG WALL,  
JOIST OFFSET FROM END POST NO SCALE

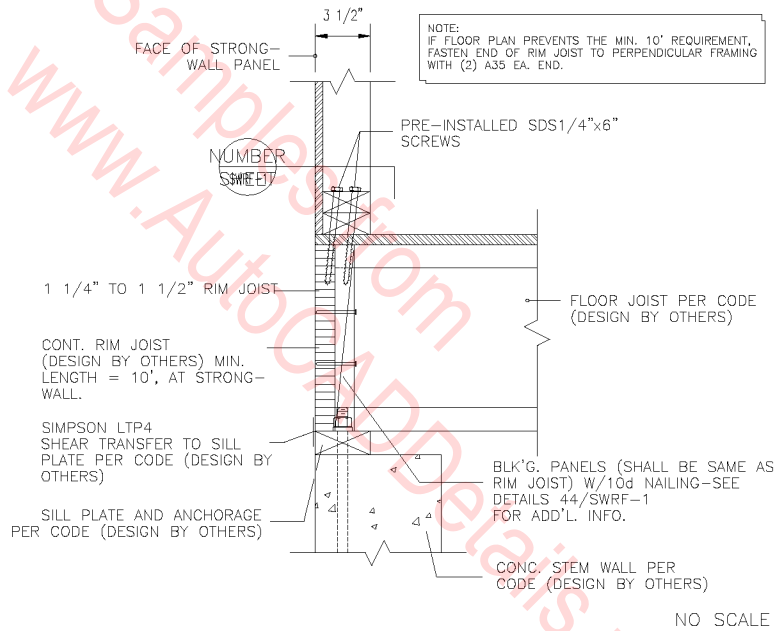

SHEAR TRANSFER AT RAISED FLOOR

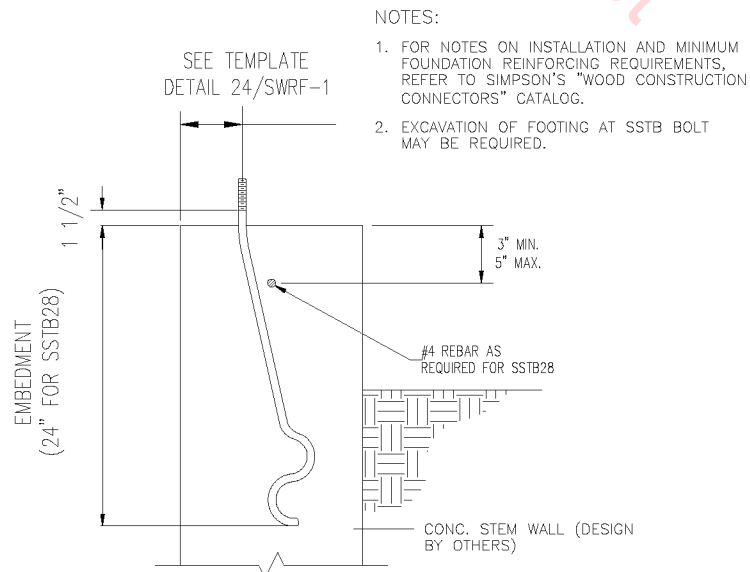

SSTB ANCHOR BOLT

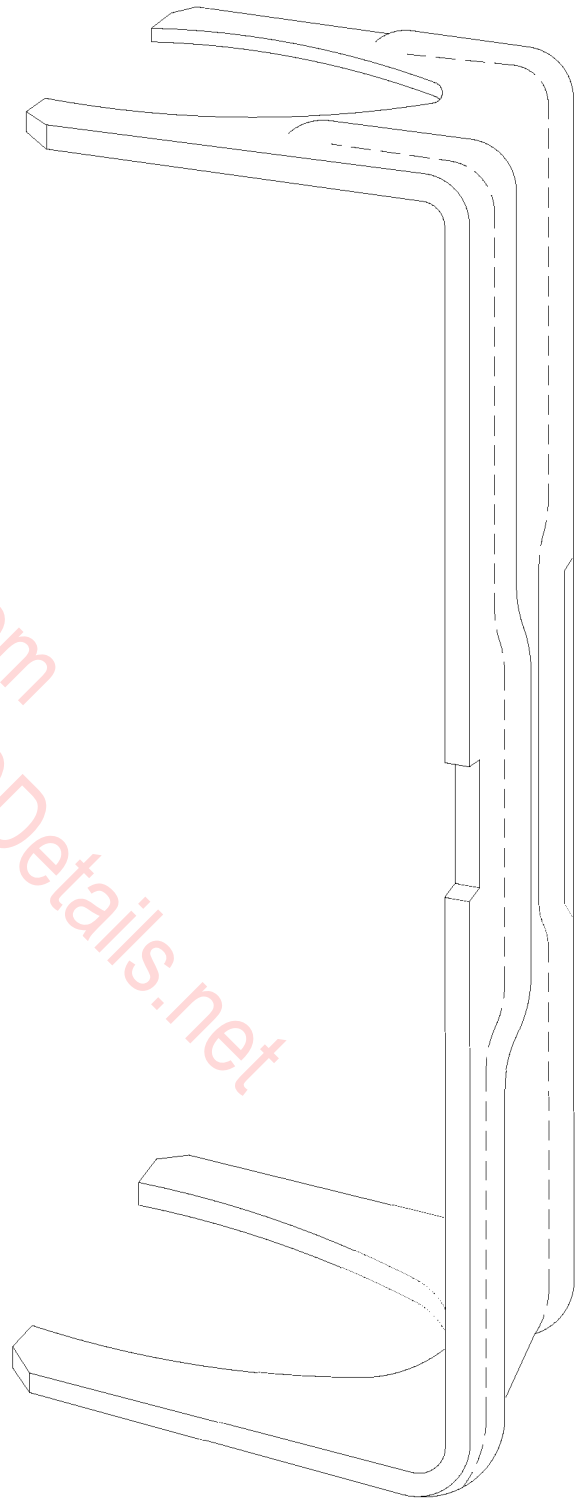
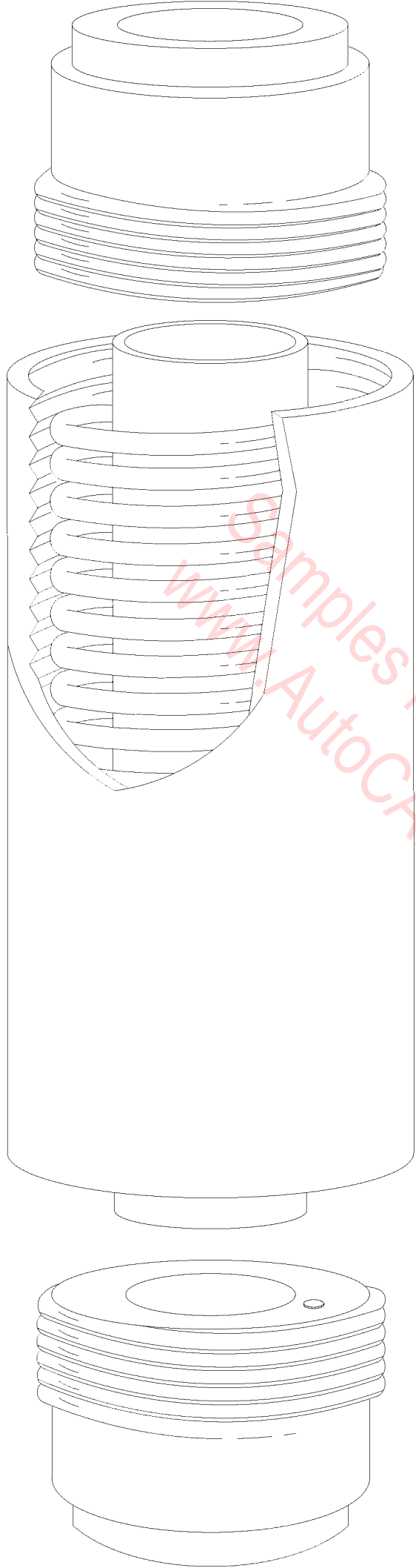

Samples from  
[www.AutoCADDetails.net](http://www.AutoCADDetails.net)

1" MAXIMUM DIAMETER HOLE IN FRAMING MEMBERS, ONLY ONE HOLE PER MEMBER.  
TYP. LOCATION OF HOLE

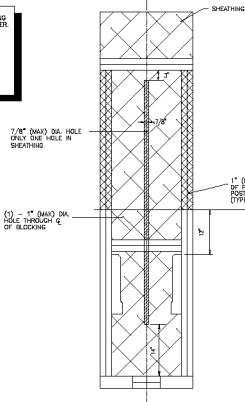

16" & 22" PORTAL WALL

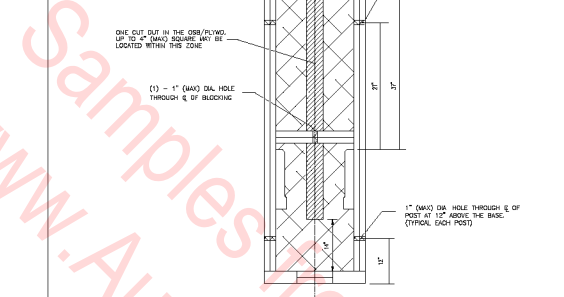

18" & 24" STANDARD OR RF WALL

1" MAXIMUM DIAMETER HOLE IN FRAMING MEMBERS, ONLY ONE HOLE PER MEMBER.  
TYP. LOCATION OF HOLE

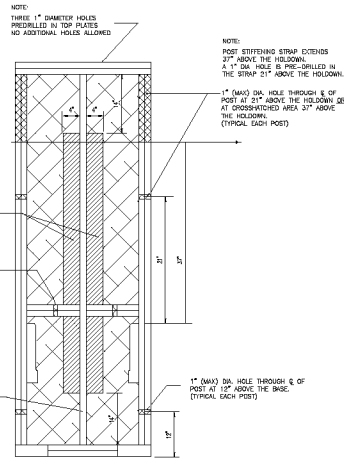

32" STANDARD OR RF WALL

1" MAXIMUM DIAMETER HOLE IN FRAMING MEMBERS, ONLY ONE HOLE PER MEMBER.  
TYP. LOCATION OF HOLE

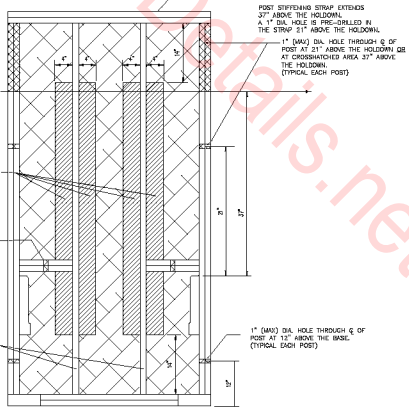

48" STANDARD OR RF WALL

1. STRONG-WALL IS MANUFACTURED AND TRADEMARKED BY SIMPSON STRONG-TIE COMPANY, INC.  
HOME OFFICE: 4125 SULLY BLVD., #400, DUBLIN, CA 94568  
TELL: (925) 399-5089, FAX: (925) 679-0826  
SIMPSON STRONG-TIE COMPANY, INC. IS AN ISO 9001 REGISTERED COMPANY.
2. INSTALLATION OF PRODUCT SHALL BE DONE IN STRICT CONFORMANCE TO THESE DRAWINGS AND THE STRONG-WALL™ INSTALLATION GUIDE. T-SPECIFIC MODIFICATIONS TO THIS PRODUCT AND ASSOCIATED SYSTEMS OR CHANGES IN THE INSTALLATION METHODS SHOWN ON THESE DRAWINGS AND THE INSTALLATION GUIDE SHOULD ONLY BE MADE BY A QUALIFIED ARCHITECT, CIVIL OR STRUCTURAL ENGINEER. THE PERFORMANCE OF SUCH MODIFIED PRODUCTS OR ALTERED INSTALLATION PROCEDURES IS THE SOLE RESPONSIBILITY OF THE DESIGNER. REFER TO U.S.G.P. PROC-5405 FOR FURTHER INFORMATION.
3. THE CONTRACTOR SHALL VERIFY ALL DIMENSIONS, CONDITIONS, ELEVATIONS, ETC. PRIOR TO INSTALLATION OF ANY COMPONENTS FOR THE STRONG-WALL SYSTEM. IF ANY DISCREPANCIES ARE FOUND, THEY SHALL BE BROUGHT TO THE ATTENTION OF THE PROJECT ARCHITECT, PROJECT ENGINEER OR BUILDING DESIGNER FOR CLARIFICATION PRIOR TO CONSTRUCTION.
4. THE CONTRACTOR SHALL VERIFY THE POSITION OF THE STRONG-WALL IN RELATION TO THE REST OF THE BUILDING SYSTEM AS SHOWN ON THE PROJECT DRAWINGS.
5. USE OF THIS PRODUCT IS SUBJECT TO THE APPROVAL OF THE LOCAL BUILDING OFFICIAL.
6. THE BUILDING STRUCTURE SHALL BE DESIGNED IN ACCORDANCE WITH THE LATEST ADOPTED VERSION OF THE UNIFORM BUILDING CODE AND ANY OTHER LOCAL, STATE OR FEDERAL REQUIREMENTS THAT MAY APPLY. VERIFY DESIGN REQUIREMENTS WITH THE LOCAL BUILDING DEPARTMENT.
7. THIS PRODUCT IS PART OF THE OVERALL LATERAL FORCE RESISTING SYSTEM OF THE STRUCTURE. DESIGN OF THE BUILDING'S LATERAL FORCE RESISTING SYSTEM INCLUDING A COMPLETE LOAD PATH NECESSARY TO TRANSFER LATERAL FORCES FROM THE STRUCTURE TO THE GROUND, IS THE RESPONSIBILITY OF THE DESIGNER.
8. SIMPSON STRONG-TIE COMPANY, INC. RESERVES THE RIGHT TO CHANGE SPECIFICATIONS, DESIGNS AND MODELS WITHOUT NOTICE OR LIABILITY FOR SUCH CHANGES.
9. ALL HARDWARE CALLED OUT IS SIMPSON STRONG-TIE.

NOTES

www.AutocADDetails.net

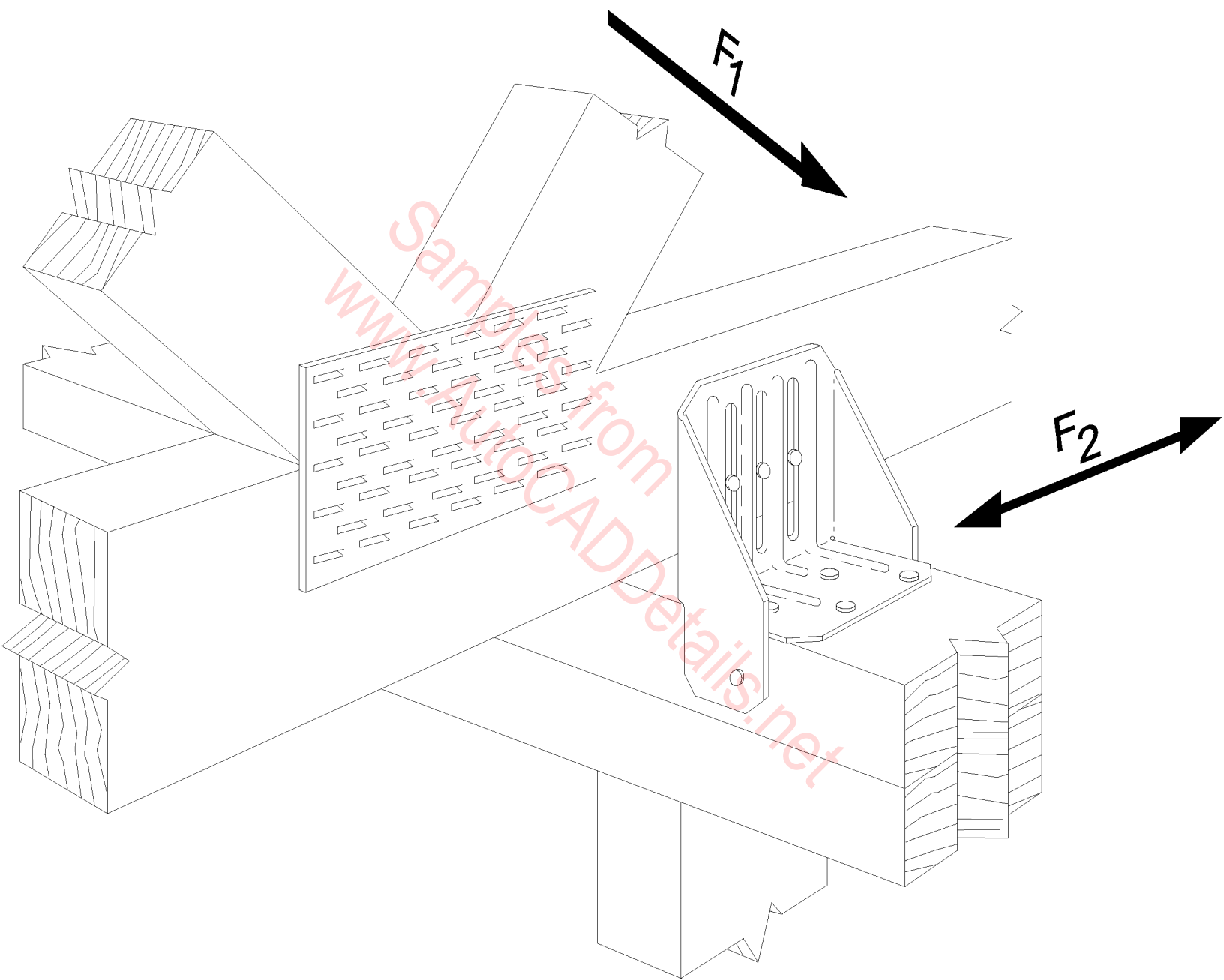

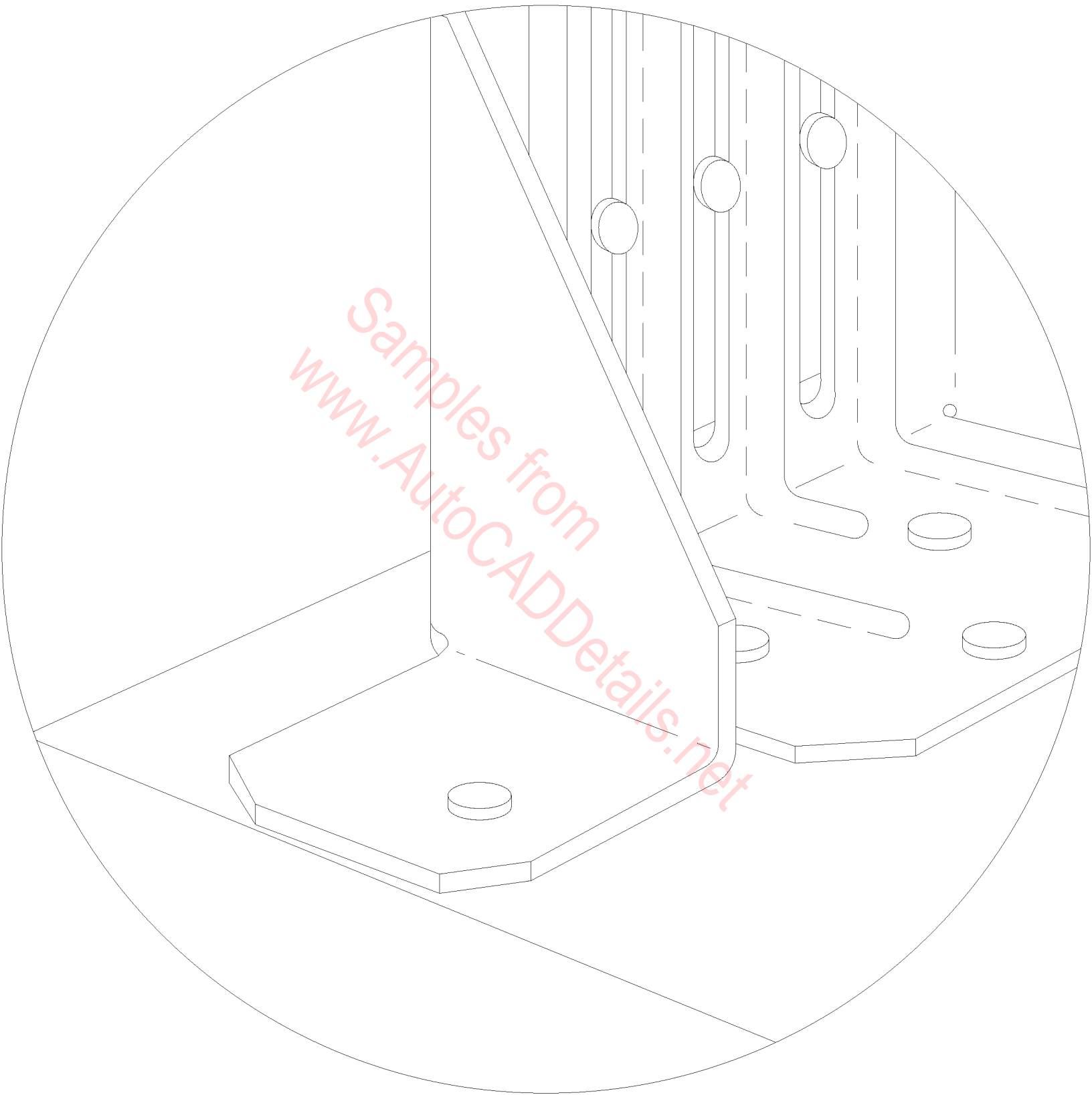

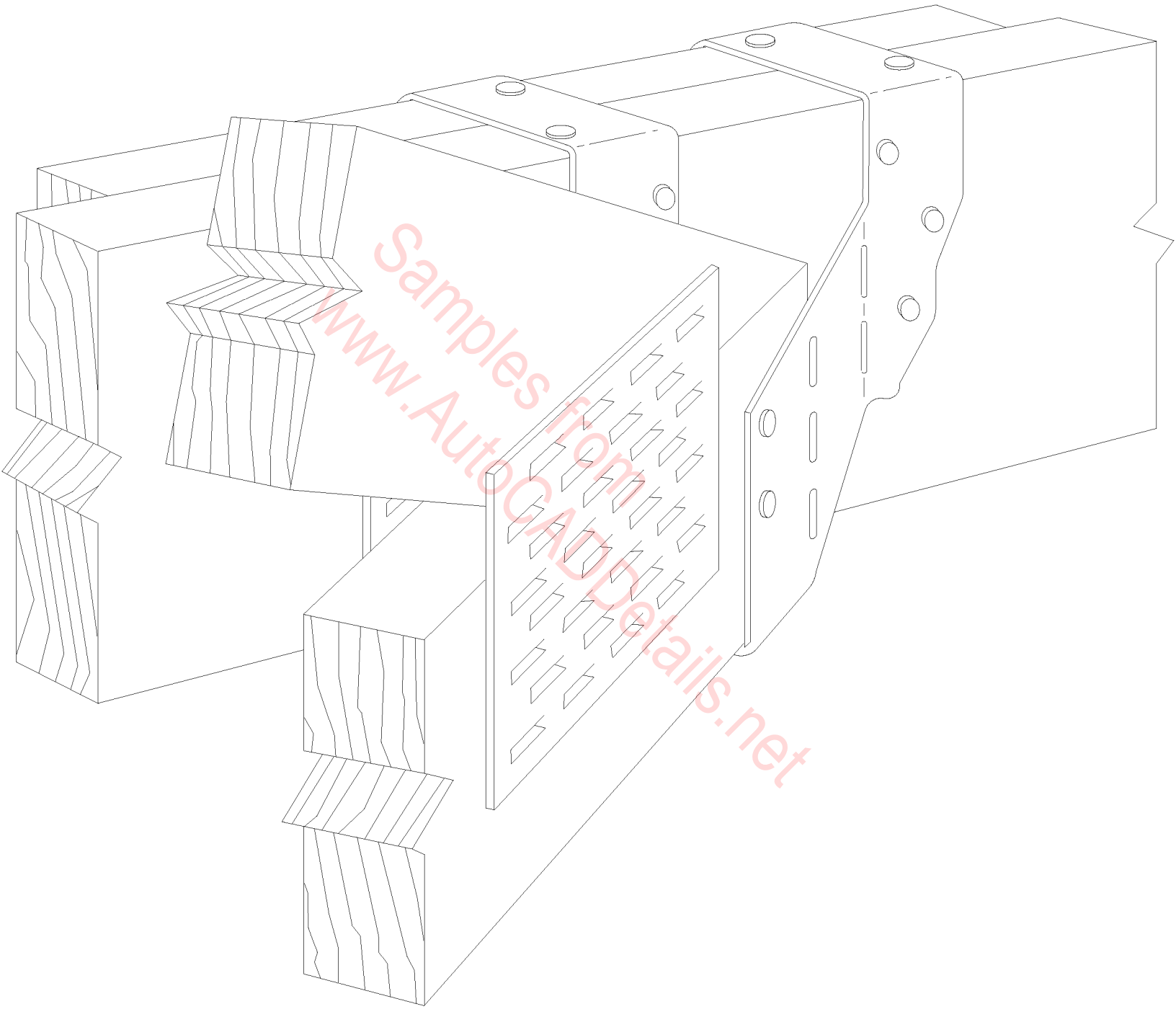

Samples from  
[www.AutoCADDetails.net](http://www.AutoCADDetails.net)

